

Edizione 002



motorquality

TECHNOLOGY FOR SPORT

Listino Prezzi
Price List

Distribution:



INDICE / INDEX

BREMBO

PASTIGLIE / BRAKE PADS

BREMBO

RICAMBI / SPARE PARTS

BREMBO

RACING / RACING COMPONENTS

BREMBO

DISCHI FRENO SERIE ORO FLOTTANTI/ SERIE ORO FLOATING BRAKE DISCS

BREMBO

DISCHI FRENO SERIE ORO FISSI / SERIE ORO FIXED BRAKE DISCS

SPRINT FILTER

FILTRI ARIA / AIR FILTERS

NITRO

BATTERIE / BATTERIES

ALLEGRI

KIT TUBAZIONI FRENO / BRAKE HOSE KITS

ALLEGRI

TUBAZIONI GLOBAL SYSTEM / GLOBAL SYSTEM

ALLEGRI

RACCORDI RECUPERABILI / RE-USABLE FITTINGS

AFAM

CATENE / CHAINS

AFAM

PIGNONI E CORONE OFF-ROAD / OFF-ROAD FRONT AND REAR SPROCKETS

AFAM

PIGNONI E CORONE / FRONT AND REAR SPROCKETS

AFAM

KIT TRASMISSIONE / TRANSMISSION KITS

MARCHESINI

RUOTE STRADA - PISTA / ROAD & TRACK WHEELS

ISON

FILTRI OLIO / OIL FILTERS

PASTIGLIE

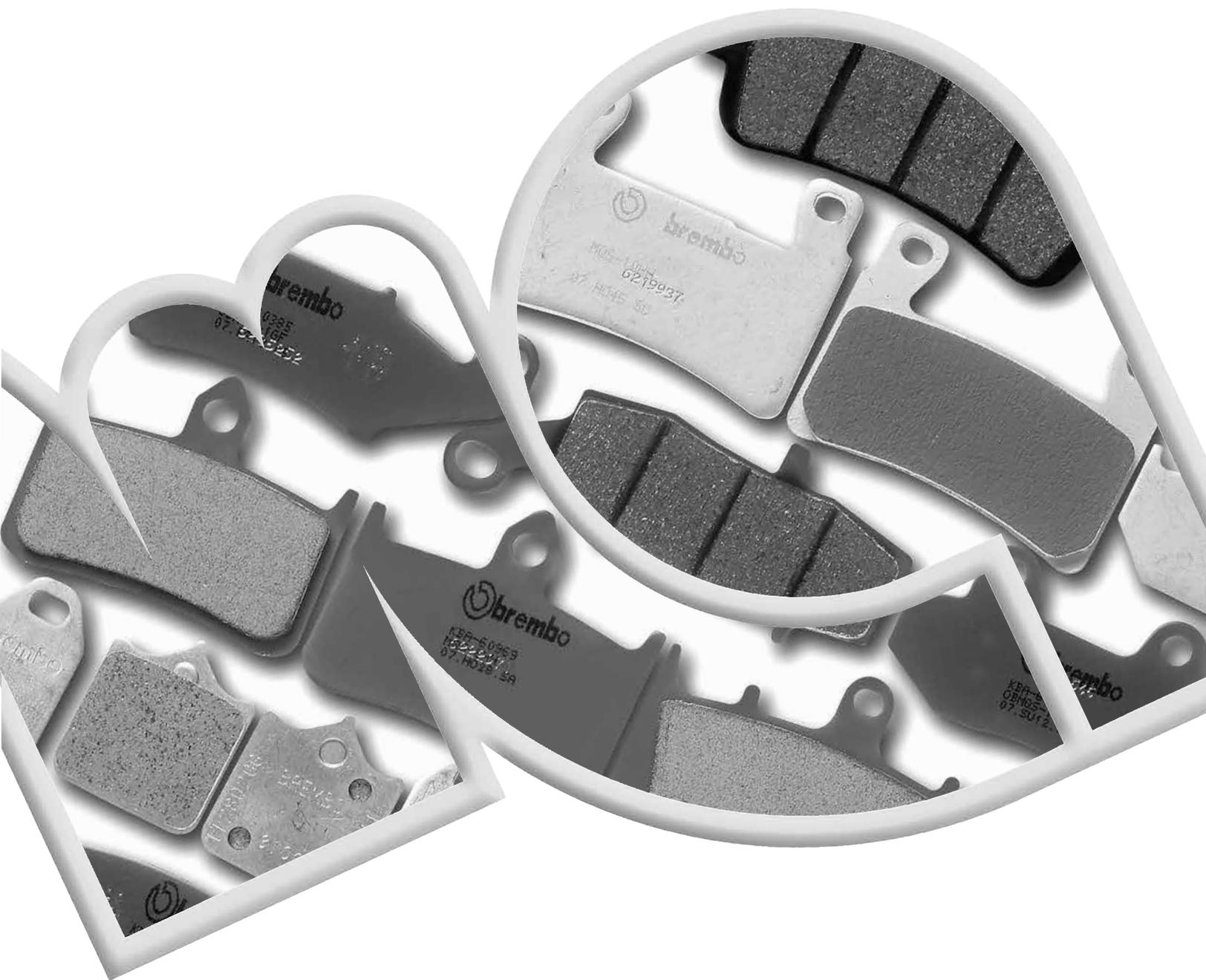

 **brembo**

 **motorquality**
TECHNOLOGY FOR SPORT



PASTIGLIE FRENO MOTO / MOTORBIKE BRAKE PADS

Code	Miscola	€	Code	Miscola	€	Code	Miscola	€
07BB0106	Carbon Ceramic	13,62	07BB19LA	Sinter Ant. La	37,08	07GR6706	Carbon Ceramic	59,04
07BB0111	Genuine	20,25	07BB19RC	Racing	60,66	07GR68SA	Sinter Ant.	49,72
07BB01SD	Off Road Sinter	29,58	07BB19SA	Sinter Ant.	34,98	07GR69SD	Off Road Sinter	29,58
07BB01SP	Sinter post.	33,58	07BB19SR	Sinter Racing	44,40	07GR69SX	Off Road Rac. Sinter	36,21
07BB01SX	Off Road Rac. Sinter	38,47	07BB2065	Genuine Sinter	41,60	07GR70SD	Off Road Sinter	29,58
07BB0258	Genuine Sinter	40,80	07BB2090	Genuine Sinter	39,19	07GR70SX	Off Road Rac. Sinter	36,21
07BB0265	Genuine Sinter	40,80	07BB209A	Genuine Sinter	43,50	07GR71SD	Off Road Sinter	50,95
07BB02CC	Carbon Ceramic	28,80	07BB2011	Genuine	22,00	07GR71SX	Off Road Rac. Sinter	52,45
07BB02SD	Off Road Sinter	29,58	07BB20CC	Carbon Ceramic	25,50	07GR72SA	Sinter Ant.	34,98
07BB02SP	Sinter Post.	31,72	07BB20SP	Sinter Post.	34,51	07GR73SD	Off Road Sinter	29,58
07BB02SX	Off Road Rac. Sinter	36,21	07BB2107	Carbon Ceramic	26,67	07GR73SX	Off Road Rac. Sinter	36,21
07BB02TT	Semi-Metal	24,50	07BB21SA	Sinter Ant.	34,51	07GR74SD	Off Road Sinter	29,58
07BB0306	Carbon Ceramic	25,68	07BB2207	Carbon Ceramic	28,36	07GR74SX	Off Road Rac. Sinter	36,21
07BB0347	Genuine	31,05	07BB22LA	Sinter Ant. La	37,70	07GR75SA	Sinter Ant.	38,34
07BB0359	Genuine Sinter	40,80	07BB22SA	Sinter Ant.	34,51	07GR75SX	Off Road Rac. Sinter	44,82
07BB0365	Genuine Sinter	40,80	07BB2307	Carbon Ceramic	25,79	07GR76RC	Racing	90,00
07BB0373	Genuine Sinter	40,80	07BB2407	Carbon Ceramic	30,70	07GR76SA	Sinter Ant.	52,97
07BB0390	Genuine Sinter	40,80	07BB24LA	Sinter Ant. LA	37,70	07GR76SX	Off Road Rac. Sinter	88,59
07BB03LA	Sinter Ant. LA	37,08	07BB24SA	Sinter Ant.	34,51	07GR7707	Carbon Ceramic	29,06
07BB03SA	Sinter Ant.	34,98	07BB2507	Carbon Ceramic	33,35	07GR77LA	Sinter Ant. La	43,50
07BB03SP	Sinter Post.	37,47	07BB2607	Carbon Ceramic	30,10	07GR77SA	Sinter Ant.	41,03
07BB0430	Genuine	26,61	07BB26LA	Sinter Ant. LA	38,75	07GR77SR	Sinter Racing	54,10
07BB0459	Genuine Sinter	41,80	07BB26SA	Sinter Ant.	36,90	07GR78CC	Carbon Ceramic	25,68
07BB0478	Genuine Sinter	41,80	07BB26SR	Sinter Racing	45,90	07GR78SD	Off Road Sinter	35,70
07BB0483	Genuine Sinter	40,80	07BB275A	Genuine Sinter	35,47	07GR79CC	Carbon Ceramic	25,68
07BB0495	Genuine Sinter	42,30	07BB27SD	Off Road Sinter	29,58	07GR80CC	Carbon Ceramic	31,48
07BB04CC	Carbon Ceramic	25,80	07BB27SX	Off Road Rac. Sinter	36,21	07GR80SA	Sinter Ant.	45,15
07BB04LA	Sinter Ant. LA	37,09	07BB27TT	Semi-Metal	25,30	07GR81CC	Carbon Ceramic	31,48
07BB04SA	Sinter Ant.	34,98	07BB2809	Carbon Ceramic	28,36	07GR81SP	Sinter Post.	45,15
07BB04SD	Off Road Sinter	29,58	07BB28SP	Sinter Post.	40,90	07GR82CC	Carbon Ceramic	16,49
07BB04SP	Sinter Post.	35,56	07BB3396	Genuine Sinter	74,55	07GR83SA	Sinter Ant.	34,98
07BB04SX	Off Road Rac. Sinter	36,21	07BB33LA	Sinter Ant. LA	60,88	07GR84CC	Carbon Ceramic	20,38
07BB04TT	Off Road Rac. Sinter	20,92	07BB33RC	Racing	88,74	07GR84SX	Off Road Rac. Sinter	36,21
07BB0606	Carbon Ceramic	29,64	07BB33SA	Sinter Ant.	58,54	07GR85SD	Off Road Sinter	29,58
07BB0708	Carbon Ceramic	25,68	07BB33SR	Sinter Racing	68,20	07GR86SD	Off Road Sinter	29,58
07BB07TT	Off Road Rac. Sinter	30,62	07BB3590	Genuine Sinter	81,20	07GR87SD	Off Road Sinter	29,58
07BB0823	Genuine	20,80	07BB3759	Genuine Sinter	48,00	07GR88SA	Sinter Ant.	34,99
07BB0907	Carbon Ceramic	28,36	07BB3791	Genuine Sinter	54,99	07GR90LA	Sinter Ant. La	37,06
07BB10RC	Racing	64,30	07BB3792	Genuine Sinter	59,10	07GR90RC	Racing	60,66
07BB10SR	Sinter Racing	49,20	07BB3793	Genuine Sinter	66,80	07GR90SA	Sinter Ant.	34,99
07BB11SR	Sinter Racing	49,20	07BB3796	Genuine Sinter	67,50	07GR90SR	Sinter Racing	45,40
07BB1205	Scooter	20,40	07BB37LA	Sinter Ant. LA	52,20	07GR91SX	Off Road Rac. Sinter	46,54
07BB12TT	Semi-Metal	17,57	07BB37RC	Racing	75,72	07GR92SX	Off Road Rac. Sinter	46,54
07BB1305	Carbon Ceramic	15,41	07BB37SA	Sinter Ant.	48,50	07GR93CC	Carbon Ceramic	42,05
07BB13SD	Off Road Sinter	29,58	07BB37SR	Sinter Racing	61,90	07GR93SP	Sinter Post.	32,50
07BB1408	Carbon Ceramic	20,50	07BB3859	Genuine Sinter	57,00	07GR94CC	Carbon Ceramic	30,47
07BB1418	Genuine	23,93	07BB3884	Genuine Sinter	60,00	07HD0105	Carbon Ceramic	36,36
07BB14SP	Sinter Post.	34,04	07BB3895	Genuine Sinter	62,90	07HD0202	Carbon Ceramic	36,36
07BB1507	Carbon Ceramic	27,85	07BB3897	Genuine Sinter	62,90	07HD0303	Carbon Ceramic	37,61
07BB15LA	Sinter Ant. La	37,08	07BB38LA	Sinter Ant. LA	36,50	07HD0413	Carbon Ceramic	40,95
07BB15RC	Racing	60,66	07BB38RC	Racing	59,01	07HD0507	Carbon Ceramic	50,14
07BB15SA	Sinter Ant.	34,98	07BB38SA	Sinter Ant.	34,50	07HD0614	Carbon Ceramic	37,61
07BB15SR	Sinter Racing	44,40	07BB38SR	Sinter Racing	42,60	07HD07SP	Sinter Post.	35,05
07BB1606	Carbon Ceramic	29,06	07BB399A	Genuine Sinter	70,40	07HD08SP	Sinter Post.	42,05
07BB1750	Scooter Sinter	33,10	07GR0101	Carbon Ceramic	17,95	07HD0910	Carbon Ceramic	49,95
07BB1834	Genuine	23,93	07GR0204	Carbon Ceramic	31,42	07HD1011	Carbon Ceramic	49,95
07BB18CC	Carbon Ceramic	23,91	07GR03CC	Carbon Ceramic	25,68	07HD1109	Carbon Ceramic	40,95
07BB1907	Carbon Ceramic	29,00	07GR05CC	Carbon Ceramic	25,34	07HD13SA	Sinter Ant.	43,20
07BB1954	Genuine Sinter	43,50	07GR06RC	Racing	60,66	07HD14SP	Sinter Post.	42,05
07BB1959	Genuine Sinter	46,30	07GR06SA	Sinter Ant.	34,98	07HD15SA	Sinter Ant.	39,72
07BB1973	Genuine Sinter	49,68	07GR06SR	Sinter Racing	44,40	07HD16CC	Carbon Ceramic	31,64
07BB1990	Genuine Sinter	49,68	07GR07SD	Off Road Sinter	29,58	07HD16SA	Sinter Ant.	39,72
07BB1996	Genuine Sinter	59,00	07GR07SX	Off Road Rac. Sinter	36,21	07HD16SP	Sinter Post.	37,93

PASTIGLIE FRENO MOTO / MOTORBIKE BRAKE PADS



Code	Miscola	€	Code	Miscola	€	Code	Miscola	€
07GR08SD	Off Road Sinter	32,64	07HD18CC	Carbon Ceramic	31,64	07HO2711	Carbon Ceramic	25,68
07GR08SX	Off Road Rac. Sinter	35,48	07HD18SP	Sinter Post.	35,83	07HO27SP	Sinter Post.	35,56
07GR09CC	Carbon Ceramic	27,85	07HD19SA	Sinter Ant.	72,00	07HO2807	Carbon Ceramic	28,15
07GR1001	Carbon Ceramic	19,90	07HD19SR	Sinter Racing	80,10	07HO28LA	Sinter Ant. LA	37,08
07GR11CC	Carbon Ceramic	28,36	07HD20SA	Sinter Ant.	43,20	07HO28RC	Racing	60,66
07GR12CC	Carbon Ceramic	21,80	07HD21CC	Carbon Ceramic	26,54	07HO28SA	Sinter Ant.	34,98
07GR12SA	Sinter Ant.	34,50	07HD21SA	Sinter Ant.	34,99	07HO28SR	Sinter Racing	44,40
07GR12SC	Sinter Racing	37,36	07HD21SP	Sinter Post.	34,99	07HO2911	Carbon Ceramic	28,36
07GR12SP	Sinter Post.	34,38	07HD22CC	Carbon Ceramic	37,10	07HO29SP	Sinter Post.	35,56
07GR13CC	Carbon Ceramic	17,36	07HD22SA	Sinter Ant.	41,92	07HO3005	Carbon Ceramic	28,36
07GR1406	Carbon Ceramic	17,54	07HD23CC	Carbon Ceramic	31,64	07HO30LA	Sinter Ant. LA	37,08
07GR1506	Carbon Ceramic	27,85	07HD23SP	Sinter Post.	35,83	07HO30SA	Sinter Ant.	34,98
07GR16SD	Off Road Sinter	29,58	07HO0130	Carbon Ceramic	31,48	07HO30SR	Sinter Racing	45,40
07GR16SX	Off Road Rac. Sinter	36,21	07HO0229	Carbon Ceramic	31,48	07HO3109	Carbon Ceramic	29,20
07GR1705	Carbon Ceramic	19,13	07HO0307	Carbon Ceramic	25,79	07HO31SP	Sinter Post.	36,60
07GR18CC	Carbon Ceramic	30,47	07HO0411	Carbon Ceramic	29,51	07HO32SD	Off Road Sinter	29,58
07GR18SA	Sinter Ant.	36,20	07HO0531	Carbon Ceramic	33,86	07HO32SP	Sinter Post.	34,04
07GR18SR	Sinter Racing	49,90	07HO0631	Carbon Ceramic	31,48	07HO32SX	Off Road Rac. Sinter	36,21
07GR19CC	Carbon Ceramic	21,28	07HO0712	Carbon Ceramic	27,85	07HO33CC	Carbon Ceramic	23,91
07GR20SD	Off Road Sinter	29,58	07HO0831	Carbon Ceramic	31,48	07HO3405	Carbon Ceramic	30,60
07GR20SX	Off Road Rac. Sinter	36,21	07HO0906	Carbon Ceramic	18,89	07HO34SP	Sinter Post.	34,10
07GR2106	Carbon Ceramic	25,79	07HO09SD	Off Road Sinter	29,58	07HO3509	Carbon Ceramic	27,85
07GR22SD	Off Road Sinter	29,58	07HO09SX	Off Road Rac. Sinter	36,21	07HO35SA	Sinter Ant.	34,98
07GR22SX	Off Road Rac. Sinter	36,21	07HO09TT	Semi-Metal	18,95	07HO3607	Carbon Ceramic	31,44
07GR23CC	Carbon Ceramic	23,22	07HO1010	Carbon Ceramic	25,79	07HO36SP	Sinter Post.	35,56
07GR24CC	Carbon Ceramic	16,50	07HO10LA	Sinter Ant. LA	37,08	07HO37SA	Sinter Ant.	67,18
07GR25SD	Off Road Sinter	29,58	07HO10SA	Sinter Ant.	34,98	07HO3907	Carbon Ceramic	31,44
07GR25SX	Off Road Rac. Sinter	39,65	07HO10SP	Sinter Post.	34,04	07HO39SA	Sinter Ant.	46,89
07GR26SD	Off Road Sinter	29,58	07HO1118	Carbon Ceramic	25,94	07HO39SP	Sinter Post.	45,89
07GR26SX	Off Road Rac. Sinter	36,21	07HO1212	Carbon Ceramic	25,79	07HO4008	Carbon Ceramic	31,94
07GR27SD	Off Road Sinter	29,58	07HO13CC	Carbon Ceramic	32,42	07HO4108	Carbon Ceramic	31,70
07GR27SX	Off Road Rac. Sinter	36,21	07HO13SP	Sinter Post.	35,56	07HO41LA	Sinter Ant. LA	40,10
07GR35SP	Sinter Post.	44,06	07HO1406	Carbon Ceramic	29,06	07HO41SA	Sinter Ant.	37,83
07GR4804	Carbon Ceramic	17,95	07HO1505	Carbon Ceramic	25,79	07HO41SR	Sinter Racing	45,40
07GR48SX	Off Road Rac. Sinter	36,21	07HO15SD	Off Road Sinter	29,58	07HO4206	Carbon Ceramic	34,06
07GR49SD	Off Road Sinter	29,58	07HO15SX	Off Road Rac. Sinter	36,21	07HO42LA	Sinter Ant. LA	47,41
07GR49SX	Off Road Rac. Sinter	36,21	07HO15TT	Semi-Metal	21,57	07HO42SA	Sinter Ant.	45,15
07GR50SD	Off Road Sinter	29,58	07HO1609	Carbon Ceramic	27,85	07HO4308	Carbon Ceramic	35,15
07GR50SX	Off Road Rac. Sinter	36,21	07HO1708	Carbon Ceramic	29,06	07HO43SP	Sinter Post.	43,51
07GR5105	Carbon Ceramic	25,79	07HO1807	Carbon Ceramic	25,79	07HO44CC	Carbon Ceramic	35,37
07GR5209	Carbon Ceramic	28,36	07HO18SP	Sinter Post.	34,04	07HO44SA	Sinter Ant.	45,15
07GR52SD	Off Road Sinter	35,70	07HO20SD	Off Road Sinter	29,58	07HO4507	Carbon Ceramic	29,06
07GR52SX	Off Road Rac. Sinter	44,82	07HO20SX	Off Road Rac. Sinter	36,21	07HO45RC	Racing	60,66
07GR53SD	Off Road Sinter	29,58	07HO20TT	Semi-Metal	18,15	07HO45SA	Sinter Ant.	34,98
07GR54SD	Off Road Sinter	29,58	07HO2107	Carbon Ceramic	27,10	07HO45SR	Sinter Racing	44,40
07GR54SX	Off Road Rac. Sinter	36,21	07HO21SA	Sinter Ant.	34,98	07HO4607	Carbon Ceramic	30,93
07GR55SD	Off Road Sinter	29,58	07HO21SR	Sinter Racing	44,40	07HO47CC	Carbon Ceramic	32,69
07GR5605	Carbon Ceramic	25,79	07HO2205	Carbon Ceramic	25,79	07HO47SA	Sinter Ant.	37,88
07GR56SR	Sinter Racing	44,40	07HO22SD	Off Road Sinter	29,58	07HO48SD	Off Road Sinter	29,58
07GR5705	Carbon Ceramic	28,35	07HO22SX	Off Road Rac. Sinter	36,21	07HO48SX	Off Road Rac. Sinter	36,21
07GR5804	Carbon Ceramic	20,37	07HO22TT	Semi-Metal	18,95	07HO48TT	Semi-Metal	25,50
07GR58SX	Off Road Rac. Sinter	36,21	07HO2307	Carbon Ceramic	27,85	07HO4905	Carbon Ceramic	28,10
07GR5915	Carbon Ceramic	31,44	07HO23SA	Sinter Ant.	34,98	07HO50LA	Sinter Ant. LA	39,77
07GR6007	Carbon Ceramic	26,67	07HO23SP	Sinter Post.	38,34	07HO50RC	Racing	60,66
07GR6207	Carbon Ceramic	33,97	07HO2408	Carbon Ceramic	25,79	07HO50SA	Sinter Ant.	37,88
07GR62LA	Sinter Ant. LA	38,90	07HO2506	Carbon Ceramic	25,68	07HO50SR	Sinter Racing	46,40
07GR62SA	Sinter Ant.	36,20	07HO25SD	Off Road Sinter	29,58	07HO52SP	Sinter Post.	40,70
07GR62SR	Sinter Racing	45,90	07HO25SX	Off Road Rac. Sinter	36,21	07HO53CC	Carbon Ceramic	33,15
07GR6319	Carbon Ceramic	27,85	07HO25TT	Semi-Metal	21,60	07HO53SP	Sinter Post.	38,34
07GR6407	Carbon Ceramic	25,79	07HO2608	Carbon Ceramic	26,30	07HO55SD	Off Road Sinter	40,80
07GR64TT	Semi-Metal	27,37	07HO26SD	Off Road Sinter	29,58	07HO5606	Carbon Ceramic	19,30
07GR6527	Carbon Ceramic	28,36	07HO26SX	Off Road Rac. Sinter	36,21	07HO57LA	Sinter Ant. LA	42,00
07GR6610	Carbon Ceramic	38,31	07HO26TT	Semi-Metal	24,30	07HO57SA	Sinter Ant.	40,00

PASTIGLIE FRENO MOTO / MOTORBIKE BRAKE PADS

Code	Miscela	€	Code	Miscela	€	Code	Miscela	€
07HO57SP	Sinter Post.	43,51	07KA19SR	Sinter Racing	51,10	07SU0125	Carbon Ceramic	31,48
07HO58SD	Off Road Sinter	40,80	07KA2009	Carbon Ceramic	32,69	07SU0220	Carbon Ceramic	31,48
07HO5907	Carbon Ceramic	33,45	07KA20RC	Racing	60,66	07SU0312	Carbon Ceramic	25,79
07HO59SP	Sinter Post.	35,56	07KA20SA	Sinter Ant.	41,03	07SU0412	Carbon Ceramic	25,96
07HO60SP	Sinter Post.	41,82	07KA20SR	Sinter Racing	50,20	07SU0526	Carbon Ceramic	31,48
07HO61CC	Carbon Ceramic	25,68	07KA2107	Carbon Ceramic	29,06	07SU0607	Carbon Ceramic	25,79
07HO61SD	Off Road Sinter	29,58	07KA21SP	Sinter Post.	41,68	07SU06SA	Sinter Ant.	34,98
07HO61SX	Off Road Rac. Sinter	36,21	07KA22SD	Off Road Sinter	29,58	07SU06SP	Sinter Post.	34,04
07HO62LA	Sinter Ant. LA	44,70	07KA22SX	Off Road Rac. Sinter	36,21	07SU0707	Carbon Ceramic	27,85
07HO62SA	Sinter Ant.	34,98	07KA2305	Carbon Ceramic	28,40	07SU0808	Carbon Ceramic	25,79
07HO63RC	Racing	60,66	07KA23LA	Sinter Ant. LA	37,08	07SU08TT	Semi-Metal	27,37
07HO63SA	Sinter Ant.	37,90	07KA23RC	Racing	60,66	07SU0904	Carbon Ceramic	27,85
07HO63SR	Sinter Racing	45,50	07KA23SA	Sinter Ant.	34,98	07SU1005	Carbon Ceramic	27,85
07HO64CC	Carbon Ceramic	31,44	07KA23SR	Sinter Racing	44,40	07SU1121	Carbon Ceramic	25,68
07HO65SA	Sinter Ant.	38,70	07KA24SD	Off Road Sinter	29,58	07SU11SD	Off Road Sinter	29,58
07HO66SP	Sinter Post.	43,51	07KA24SX	Off Road Rac. Sinter	36,21	07SU11SX	Off Road Rac. Sinter	36,21
07KA0122	Carbon Ceramic	25,79	07KA25SD	Off Road Sinter	29,58	07SU1215	Carbon Ceramic	25,10
07KA0223	Carbon Ceramic	33,75	07KA25SX	Off Road Rac. Sinter	36,21	07SU12SD	Off Road Sinter	29,58
07KA0328	Carbon Ceramic	27,85	07KA26SA	Sinter Ant.	31,48	07SU12SP	Sinter Post.	33,50
07KA0414	Carbon Ceramic	31,48	07KA27SD	Off Road Sinter	29,58	07SU12SX	Off Road Rac. Sinter	36,21
07KA0506	Carbon Ceramic	27,85	07KA27SX	Off Road Rac. Sinter	36,21	07SU12TT	Semi-Metal	27,55
07KA0608	Carbon Ceramic	25,79	07KA28LA	Sinter Ant. LA	58,05	07SU1306	Carbon Ceramic	25,79
07KA0717	Carbon Ceramic	25,68	07KA28RC	Racing	88,74	07SU13SA	Sinter Ant.	34,98
07KA07SD	Off Road Sinter	29,58	07KA28SA	Sinter Ant.	55,82	07SU13SP	Sinter Post.	34,04
07KA07SX	Off Road Rac. Sinter	36,21	07KA28SR	Sinter Racing	71,30	07SU1407	Carbon Ceramic	25,79
07KA0808	Carbon Ceramic	28,36	07KA29RC	Racing	60,66	07SU14LA	Sinter Ant. La	37,08
07KA08SA	Sinter Ant.	34,98	07KA29SA	Sinter Ant.	33,35	07SU14RC	Racing	60,66
07KA08SP	Sinter Post.	35,56	07KA29SR	Sinter Racing	40,20	07SU14SA	Sinter Ant.	34,98
07KA0933	Carbon Ceramic	30,10	07KA30CC	Carbon Ceramic	18,53	07SU14SR	Sinter Racing	44,40
07KA09SA	Sinter Ant.	37,00	07KA31RC	Racing	60,66	07SU1509	Carbon Ceramic	28,36
07KA09SP	Sinter Post.	35,56	07KA31SA	Sinter Ant.	34,98	07SU15SA	Sinter Ant.	38,70
07KA10TT	Semi-Metal	26,46	07KA31SR	Sinter Racing	44,40	07SU15TT	Semi-Metal	27,37
07KA1117	Carbon Ceramic	28,36	07KS0124	Carbon Ceramic	31,48	07SU16CC	Carbon Ceramic	38,29
07KA11SA	Sinter Ant.	34,98	07KS0207	Carbon Ceramic	31,42	07SU16SP	Sinter Post.	43,51
07KA11SP	Sinter Post.	35,56	07KS0321	Carbon Ceramic	27,85	07SU1718	Carbon Ceramic	28,36
07KA12SD	Off Road Sinter	32,64	07KS0432	Carbon Ceramic	25,68	07SU17SP	Sinter Post.	35,56
07KA12SX	Off Road Rac. Sinter	36,21	07KS04SD	Off Road Sinter	29,58	07SU17TT	Semi-Metal	27,37
07KA12TT	Semi-Metal	25,35	07KS04SX	Off Road Rac. Sinter	36,21	07SU18SD	Off Road Sinter	29,58
07KA1306	Carbon Ceramic	27,50	07KS04TT	Semi-Metal	27,13	07SU18TT	Semi-Metal	27,37
07KA13LA	Sinter Ant. LA	37,08	07KS0507	Carbon Ceramic	25,79	07SU1907	Carbon Ceramic	31,60
07KA13RC	Racing	60,66	07KS05SP	Sinter Post.	34,04	07SU19LA	Sinter Ant. La	40,80
07KA13SA	Sinter Ant.	34,98	07PO0106	Carbon Ceramic	27,85	07SU19RC	Racing	60,66
07KA13SR	Sinter Racing	44,40	07PO01SD	Off Road Sinter	29,58	07SU19SA	Sinter Ant.	36,10
07KA1406	Carbon Ceramic	25,79	07PO01SX	Off Road Rac. Sinter	36,21	07SU19SR	Sinter Racing	44,40
07KA14SA	Sinter Ant.	34,98	07PO02SD	Off Road Sinter	29,58	07SU2007	Carbon Ceramic	27,85
07KA14SR	Sinter Racing	44,40	07PO03SD	Off Road Sinter	29,58	07SU20SP	Sinter Post.	34,04
07KA15CC	Carbon Ceramic	38,29	07PO03SX	Off Road Rac. Sinter	36,21	07SU22SA	Sinter Ant.	34,98
07KA15SP	Sinter Post.	40,66	07PO04SD	Off Road Sinter	29,58	07SU25SP	Sinter Post.	35,10
07KA1617	Carbon Ceramic	29,95	07PO04SX	Off Road Rac. Sinter	36,21	07SU26LA	Sinter Ant. La	58,05
07KA16SP	Sinter Post.	35,56	07PO05SX	Off Road Rac. Sinter	44,82	07SU26RC	Racing	92,00
07KA1705	Carbon Ceramic	28,75	07PO06SD	Off Road Sinter	40,80	07SU26SA	Sinter Ant.	55,82
07KA17LA	Sinter Ant. LA	35,10	07PO06SX	Off Road Rac. Sinter	44,82	07SU26SR	Sinter Racing	71,30
07KA17SD	Off Road Sinter	29,58	07PO07SD	Off Road Sinter	40,80	07SU27LA	Sinter Ant. La	37,08
07KA17SX	Off Road Rac. Sinter	36,21	07PO08SD	Off Road Sinter	35,70	07SU27RC	Racing	60,66
07KA17TT	Semi-Metal	24,50	07PO09SD	Off Road Sinter	40,80	07SU27SA	Sinter Ant.	34,98
07KA1807	Carbon Ceramic	27,75	07PO10SD	Off Road Sinter	40,80	07SU27SR	Sinter Racing	46,40
07KA18LA	Sinter Ant. LA	43,76	07PO11SD	Off Road Sinter	40,80	07SU2906	Carbon Ceramic	21,55
07KA18SA	Sinter Ant.	41,68	07PO12SD	Off Road Sinter	29,58	07SU29SD	Off Road Sinter	29,58
07KA18SR	Sinter Racing	51,10	07PO12SX	Off Road Rac. Sinter	36,21	07SU29SX	Off Road Rac. Sinter	36,21
07KA18SP	Sinter Post.	43,51	07PO13SD	Off Road Sinter	29,58	07SU3002	Carbon Ceramic	32,80
07KA1907	Carbon Ceramic	27,75	07PO13SX	Off Road Rac. Sinter	36,21	07SU30SP	Sinter Post.	34,04
07KA19LA	Sinter Ant. LA	43,76	07PO14SD	Off Road Sinter	29,58	07SU31SD	Off Road Sinter	32,64
07KA19SA	Sinter Ant.	41,68	07PO14SX	Off Road Rac. Sinter	36,21	07SU32SP	Sinter Post.	32,40

PASTIGLIE FRENO MOTO / MOTORBIKE BRAKE PADS



Code	Miscola	€	Code	Miscola	€	Code	Miscola	€
07SU33CC	Carbon Ceramic	29,06	07YA26SA	Sinter Ant.	34,98			
07SU33SA	Sinter Ant.	34,98	07YA26SC	Sinter Racing	44,60			
07SU33SR	Sinter Racing	44,40	07YA2709	Carbon Ceramic	32,20			
07YA0113	Carbon Ceramic	25,79	07YA27SA	Sinter Ant.	34,98			
07YA0207	Carbon Ceramic	25,79	07YA28CC	Carbon Ceramic	31,44			
07YA0309	Carbon Ceramic	25,79	07YA29CC	Carbon Ceramic	41,02			
07YA0413	Carbon Ceramic	31,44	07YA3108	Carbon Ceramic	43,03			
07YA0527	Carbon Ceramic	28,36	07YA3208	Carbon Ceramic	41,37			
07YA0609	Carbon Ceramic	27,85	07YA32SA	Sinter Ant.	49,72			
07YA0713	Carbon Ceramic	31,44	07YA32SR	Sinter Racing	61,90			
07YA0809	Carbon Ceramic	27,85	07YA3408	Carbon Ceramic	27,55			
07YA09CC	Carbon Ceramic	50,62	07YA34LA	Sinter Ant. La	37,08			
07YA09SA	Sinter Ant.	52,50	07YA34SA	Sinter Ant.	34,98			
07YA1011	Carbon Ceramic	25,79	07YA3507	Carbon Ceramic	25,79			
07YA1107	Carbon Ceramic	27,45	07YA35SA	Sinter Ant.	34,98			
07YA11SA	Sinter Ant.	34,98	07YA3707	Carbon Ceramic	27,85			
07YA11SP	Sinter Post.	34,04	07YA37SP	Sinter Post.	35,10			
07YA1207	Carbon Ceramic	25,79	07YA3807	Carbon Ceramic	27,85			
07YA12SA	Sinter Ant.	34,98	07YA38SP	Sinter Post.	34,04			
07YA12SP	Sinter Post.	34,04	07YA3908	Carbon Ceramic	29,06			
07YA13SD	Off Road Sinter	29,58	07YA39SP	Sinter Post.	35,10			
07YA13SX	Off Road Rac. Sinter	36,21	07YA4007	Carbon Ceramic	27,85			
07YA13TT	Semi-Metal	27,37	07YA40SP	Sinter Post.	34,04			
07YA1407	Carbon Ceramic	25,30	07YA41SD	Off Road Sinter	29,58			
07YA14SD	Off Road Sinter	29,58	07YA41SX	Off Road Rac. Sinter	36,21			
07YA14SX	Off Road Rac. Sinter	36,21	07YA41TT	Semi-Metal	24,05			
07YA1519	Carbon Ceramic	32,69	07YA44SD	Off Road Sinter	40,80			
07YA1605	Carbon Ceramic	23,03	07YA45SD	Off Road Sinter	40,80			
07YA16SD	Off Road Sinter	29,58	07YA46RC	Racing	102,50			
07YA16SX	Off Road Rac. Sinter	36,21	07YA46SA	Sinter Ant.	62,00			
07YA1711	Carbon Ceramic	27,85	07YA46SR	Sinter Racing	77,30			
07YA17SA	Sinter Ant.	34,98	07YA47SD	Off Road Sinter	29,58			
07YA17SP	Sinter Post.	34,04	07YA47SX	Off Road Rac. Sinter	36,21			
07YA1809	Carbon Ceramic	25,79	07YA48SD	Off Road Sinter	35,70			
07YA18SA	Sinter Ant.	34,98	07YA48SX	Off Road Rac. Sinter	44,82			
07YA18TT	Semi-Metal	27,37	07YA49SD	Off Road Sinter	35,70			
07YA1909	Carbon Ceramic	27,85	07YA49SX	Off Road Rac. Sinter	44,82			
07YA2008	Carbon Ceramic	25,68	07YA50SD	Off Road Sinter	35,70			
07YA20SP	Sinter Post.	35,56	07YA50SX	Off Road Rac. Sinter	44,82			
07YA20TT	Semi-Metal	24,85	07YA51SD	Off Road Sinter	35,70			
07YA2106	Carbon Ceramic	25,68	07YA51SX	Off Road Rac. Sinter	44,82			
07YA21LA	Sinter Ant. La	37,08	07YA52CC	Carbon Ceramic	27,54			
07YA21SA	Sinter Ant.	34,98	07YA52SA	Sinter Ant.	39,60			
07YA21SD	Off Road Sinter	29,58	07YA52SR	Sinter Racing	44,60			
07YA21SX	Off Road Rac. Sinter	36,21	07YA53CC	Carbon Ceramic	25,70			
07YA2206	Carbon Ceramic	25,68	07YA54CC	Carbon Ceramic	24,68			
07YA22LA	Sinter Ant. La	37,10	07YA54SD	Off Road Sinter	29,58			
07YA22SA	Sinter Ant.	34,98	07YA54SP	Sinter Post.	42,94			
07YA22SD	Off Road Sinter	29,58	07YA54SX	Off Road Rac. Sinter	36,21			
07YA22SP	Sinter Post.	37,47						
07YA22SR	Sinter Racing	45,40						
07YA22SX	Off Road Rac. Sinter	36,21						
07YA2307	Carbon Ceramic	27,35						
07YA23LA	Sinter Ant. La	37,08						
07YA23RC	Racing	60,66						
07YA23SA	Sinter Ant.	34,98						
07YA23SR	Sinter Racing	46,40						
07YA2409	Carbon Ceramic	29,06						
07YA24SA	Sinter Ant.	34,98						
07YA24SC	Sinter Racing	62,60						
07YA2508	Carbon Ceramic	28,36						
07YA25SA	Sinter Ant.	34,98						
07YA2609	Carbon Ceramic	31,48						



PASTIGLIE FRENO SCOOTER / SCOOTER BRAKE PADS

Code	Mescola	€	Code	Mescola	€	Code	Mescola	€
07001	Scooter	16,10	07045	Scooter	17,99	07082XS	Scooter Sinter	23,65
07001XS	Scooter Sinter	26,20	07045XS	Scooter Sinter	26,20	07083	Scooter	23,30
07002	Scooter	11,55	07046	Scooter	13,88	07083XS	Scooter Sinter	25,55
0700234	Scooter Genuine	14,85	07047	Scooter	13,44	07084	Scooter	17,46
07003	Scooter	14,60	07047XS	Scooter Sinter	26,20	0708424	Scooter Genuine	20,60
0700334	Scooter Genuine	23,93	07048	Scooter	15,78	07085CC	Scooter	22,06
07004	Scooter	14,69	07049	Scooter	18,71	07085XS	Scooter Sinter	26,20
0700465	Scooter Gen. Sinter	43,00	07050	Scooter	25,80	07086	Scooter	13,96
07004XS	Scooter Sinter	26,20	07050XS	Scooter Sinter	40,15	07087CC	Scooter	19,54
07005	Scooter	18,52	07051	Scooter	16,40	07088CC	Scooter	15,62
07006	Scooter	13,94	07052	Scooter	20,13	07089CC	Scooter	16,40
07006XS	Scooter Sinter	26,20	07052XS	Scooter Sinter	26,20	07090	Scooter	22,06
07007	Scooter	12,64	07053	Scooter	19,50	07091	Scooter	22,06
07008	Scooter	11,34	07053XS	Scooter Sinter	26,20	07092	Scooter	22,06
07009	Scooter	12,30	07054	Scooter	14,69	07093	Scooter	22,06
07010	Scooter	13,46	07055	Scooter	21,40	07094CC	Scooter	20,35
07011	Scooter	12,80	07055XS	Scooter Sinter	26,20	07095	Scooter	22,06
07012	Scooter	12,64	07056	Scooter	18,71	07095XS	Scooter Sinter	26,20
07012XS	Scooter Sinter	26,20	07056XS	Scooter Sinter	26,20	07096	Scooter	22,10
07013	Scooter	13,46	07057	Scooter	15,78	07096XS	Scooter Sinter	26,20
07014	Scooter	19,66	07057XS	Scooter Sinter	26,20	07097CC	Scooter	23,74
07015	Scooter	18,71	07058	Scooter	22,60	07098CC	Scooter	23,62
07016	Scooter	15,78	07058XS	Scooter Sinter	26,20	07099CC	Scooter	23,62
07017	Scooter	13,46	07059	Scooter	18,52	07100CC	Scooter	18,75
07018	Scooter	18,71	07059XS	Scooter Sinter	26,20	07100XS	Scooter Sinter	26,20
07019	Scooter	10,76	07060	Scooter	18,52	07101CC	Scooter	27,45
07019XS	Scooter Sinter	26,20	07060XS	Scooter Sinter	26,20	07101XS	Scooter Sinter	26,20
07020	Scooter	12,64	07061	Scooter	14,18	07102CC	Scooter	17,99
07020XS	Scooter Sinter	26,20	07061XS	Scooter Sinter	26,20	07103CC	Scooter	22,06
07021	Scooter	13,50	07062	Scooter	18,52	07103XS	Scooter Sinter	26,20
07021XS	Scooter Sinter	26,20	07063	Scooter	22,60	07104XS	Scooter Sinter	26,20
07022	Scooter	17,99	07063XS	Scooter Sinter	26,20	07106CC	Scooter	14,69
07022XS	Scooter Sinter	26,20	07064	Scooter	20,13	07108CC	Scooter	16,64
07023	Scooter	32,80	07064XS	Scooter Sinter	26,20	07108XS	Scooter Sinter	26,20
07024	Scooter	17,01	07065	Scooter	19,30	07109CC	Scooter	16,64
07025	Scooter	20,30	07065XS	Scooter Sinter	26,20	07109XS	Scooter Sinter	26,20
07026	Scooter	14,18	07066	Scooter	13,20	07110CC	Scooter	16,64
07027	Scooter	18,71	0706623	Scooter Genuine	19,49	07111CC	Scooter	17,99
07028	Scooter	18,71	07066XS	Scooter Sinter	26,20	07112CC	Scooter	17,99
07029	Scooter	17,99	07067	Scooter	13,03	07113CC	Scooter	22,06
07029XS	Scooter Sinter	26,20	07067XS	Scooter Sinter	26,20	07114CC	Scooter	22,06
07030	Scooter	19,54	07068	Scooter	17,17	07115CC	Scooter	20,13
07031	Scooter	19,49	07069	Scooter	18,71			
07032	Scooter	18,71	07069XS	Scooter Sinter	26,20			
07033	Scooter	13,88	07070	Scooter	18,60			
07033XS	Scooter Sinter	26,20	07071	Scooter	18,20			
07034	Scooter	20,13	07071XS	Scooter Sinter	26,20			
07034XS	Scooter Sinter	26,20	07072	Scooter	20,60			
07035	Scooter	18,71	07072XS	Scooter Sinter	26,20			
07036	Scooter	18,52	07073	Scooter	23,20			
07037	Scooter	25,10	07073XS	Scooter Sinter	26,20			
07037XS	Scooter Sinter	40,15	07074	Scooter	14,69			
07038	Scooter	14,69	07074XS	Scooter Sinter	26,20			
07038XS	Scooter Sinter	26,20	07075XS	Scooter Sinter	26,20			
07039	Scooter	18,71	07076	Scooter	18,52			
07040	Scooter	18,71	07076XS	Scooter Sinter	26,20			
07040XS	Scooter Sinter	26,20	07077	Scooter	20,13			
07041	Scooter	17,01	07077XS	Scooter Sinter	26,20			
07042	Scooter	17,65	07078	Scooter	17,01			
07042XS	Scooter Sinter	26,20	07078XS	Scooter Sinter	26,20			
07043	Scooter	19,07	07080	Scooter	18,20			
07043XS	Scooter Sinter	26,20	07081	Scooter	17,46			
07044	Scooter	12,59	07082	Scooter	22,06			

COMPONENTI E RICAMBI



 **brembo**®

 **motorquality**
TECHNOLOGY FOR SPORT

Code	Description	€	Code	Description	€
RACCORDI / FITTINGS			POMPE FRIZIONE / CLUTCH MASTER CYLINDER		
06222830	Bocchettone 10X1	8,50	10A03911	PSC12 nera con serbatoio	318,00
06222838	Bocch. 10x1 per spurgo 05144011	12,90	10D32739	PR15 silver senza serbatoio	218,00
06222870	Bocch. Corto M10x1 t/ribas.	3,00	10D32753	PR15 titanium senza serbatoio	200,00
06222897	Bocchettone	3,80	10467014	PS13 nera con serbatoio	108,00
0626MQ20	Idrostop corto 10x1 c/switch	11,20	10467016	PS13 nera con serbatoio	94,00
0626MQ21	Idrostop corto 10x1,25 c/switch	11,20	10467017	PS13 nera con serbatoio	100,00
0626MQ22	Idrostop corto 3/8 x 24 c/switch	17,00	10467018	PS13 nera con serbatoio	99,00
0626MQ30	Idrostop lungo M10x1 c/switch	16,00	10467019	PPS13 nera con serbatoio	188,00
0626MQ31	Idrostop lungo M10x1,25 c/switch	16,00	10467021	PS13 nera con serbatoio	188,00
SERBATOI / RESERVOIRS			POMPE ANTERIORI / FRONT MASTER CYLINDER		
10321410	S30 Serbatoio fluido freni	11,60	10B29149	PR 16 silver senza serbatoio	298,00
10444630	S30 uscita diritta att. singola vite	9,60	10B89610	PS 10 silver con serbatoio	171,00
10444640	S15 uscita diritta attacco verticale	7,80	10B89650	PS 10 silver con serbatoio	171,00
10444643	S15 uscita diritta attacco vert. fume'	13,50	10D34140	PR 15/18 silver senza serbatoio	180,00
10444650	S15 uscita 45° attacco verticale	8,50	10D34161	PR 15 silver con serbatoio	158,00
10444653	S15 uscita 45° att. verticale fume'	14,70	10D34170	PR18 silver con serbatoio	327,00
10444661	S45 uscita 90° attacco foro grande	16,30	10D34173	PR18 silver senza serbatoio	184,00
10444663	S45 uscita 90° att. foro grande fume'	36,60	10D34178	PR18 silver senza serbatoio	196,00
10444670	S20 uscita diritta senza attacco	12,10	10D34189	PR18 silver senza serbatoio	212,00
10444685	S31 uscita diritta senza attacco	20,00	10462024	PS13 nera con serbatoio	109,00
			10462047	PS16 nera con serbatoio	131,00
			10462067	PS15 nera con serbatoio	133,00
			10462073	PS13 nera con serbatoio	107,00
			10462077	PS13 nera con serbatoio	105,00
			10462078	PS13 nera con serbatoio	93,00
			10462079	PS13 nera con serbatoio	116,00
			10462082	PS11 nera con serbatoio	108,00
			10462087	PS16 nera con serbatoio	128,00
			10462089	PS16 nera con serbatoio	99,00
			10462092	PS16 nera con serbatoio	142,00
			10462093	PS16 nera con serbatoio	148,00
			10462094	PS13 nera con serbatoio	192,00
			10462095	PS13 nera con serbatoio	99,00
			10505310	PS16 nera senza serbatoio	109,00
			10505312	PS16 oro senza serbatoio	119,00
			10505316	PS16 nera senza serbatoio	137,00
			10505318	PS16 nera senza serbatoio	113,00
			10505319	PS16 nera senza serbatoio	109,00
			10505351	PS13 nera senza serbatoio	119,00
			10539316	PS11 nera con serbatoio	91,00
			10670768	PS12 nera sx con serbatoio	80,00
			10687018	PSC 15 oro senza serbatoio	156,00
			10687042	PSC 16 nera senza serbatoio	169,00
			10688032	PS13 nera con serbatoio	156,00
			10688035	PS13 nera con serbatoio	149,00
			10689032	PS13 nera con serbatoio	137,00
			10689081	PS15 nera con serbatoio	202,00
			10767731	PS10 silver con serbatoio	129,00
			10767750	PS11 silver con serbatoio	138,00
			10767751	PS11 silver con serbatoio	151,00
			10767774	PS09 silver con serbatoio	146,00
			10821051	PR18 silver senza serbatoio	267,00
			10821063	PR18 silver senza serbatoio	234,00
			10821081	PR15 silver senza serbatoio	353,00
			10972084	PS13 nera con serbatoio	211,00
			10977010	PSC16 nera senza serbatoio	143,00
			10977011	PSC16 oro senza serbatoio	159,00
			10977025	PSC16 oro senza serbatoio	169,00
			10977051	PSC16 silver senza serbatoio	169,00
			10A90346	PS13 titanio int.40 mm	66,00
			10477610	PS11 nera int.40 mm	56,00
			10477620	PS13 nera int.40 mm	57,00
			10477623	PS13 nera int.40 mm	60,00
			10477634	PS12 nera int.40 mm	71,00
			10477650	PS11 nera int.40 mm	56,00
			10477651	PS11 oro int.40 mm	52,00
			10477653	PS11 nera int.40 mm	51,00
			10477658	PS11 titanio int.40 mm	56,00
			10477660	PS13 nera int.40 mm	59,00
			10477665	PS16 nera int.50 mm	100,00
			10477666	PS13 silver int.40 mm	54,00
			10477677	PS11 silver int.40 mm	55,00
			10477680	PS12 nera int.40 mm	66,00
			10477682	PS12 nera int.40 mm	65,00
			10477683	PS13 nera int.40 mm	65,00
			10555610	PS12,7 nera int. 48	83,00
			10849411	PS13 silver con serbatoio	150,00
			10850520	PS12 silver con serbatoio	107,00

COMPONENTI E RICAMBI COMPONENTS AND SPARE PARTS



Code	Description	€
10850560	PS13 silver con serbatoio	107,00
10A90346	PS 13 silver att. 40 mm. uscita dritta	66,00

RICAMBI POMPE / MASTER CYLINDER SPARE PARTS

05144011	Spurgo per bocch. 06222838	5,90
05338760	Spurgo (m10)	4,40
05338763	Spurgo (M10)	7,20
05338790	Spurgo (M10)	2,60
05442490	Vite	2,90
10270477	Tappo serbatoio rettangolare PS11	10,20
10273920	Kit guarnizioni PS 15	18,80
10279720	Kit guarnizioni PS 12	16,50
10279812	Perno leva	9,40
10279814	Perno leva	7,60
10279815	Perno leva	7,20
10279850	Perno leva	4,90
10281522	Cavallotto silver freno	9,20
10281594	Cavallotto nero freno	7,20
10300510	Perno leva	3,40
10300530	Perno leva	3,80
10312710	Raccordo innesto serbatoio 0°	5,20
10312720	Raccordo innesto serbatoio 90°	5,40
10312740	Raccordo innesto serbatoio 45°	9,50
10353010	Cuffia parapolvere	6,90
10353050	Cuffia parapolvere	9,10
10353051	Cuffia parapolvere	5,70
10374120	Cuffia parapolvere	4,00
10374170	Cuffia parapolvere	2,60
10377310	Kit guarnizioni PS 15 post.	17,00
10430811	Tappo serbatoio rettangolare PS11	11,60
10430830	Tappo serbatoio tondo PS11/12	8,20
10430860	Tappo serbatoio rettangolare	9,60
10430884	Tappo per serbatoio 10444640-50-53	15,70
10430890	Tappo per serbatoio 10444660	17,60
10430891	Tappo per serbatoio 10444661-63	10,50
10436241	Kit guarnizioni PS 11 post.	12,90
10436250	Kit guarnizioni PS 13	17,60
10437212	Cavallotto nero freno/frizione	9,90
10437216	Cavallotto porta specchio nero freno	10,70
10437219	Cavallotto porta specchio nero freno	18,50
10437220	Cavallotto nero freno	9,90
10437222	Cavallotto oro freno/frizione	10,50
10437223	Cavallotto nero freno	9,10
10437225	Cavallotto nero freno	7,40
10437229	Cavallotto porta specchio oro frizione	10,40
10437230	Cavallotto porta specchio oro freno	12,60
10437234	Cavallotto porta specchio oro freno/friz.	9,10
10437250	Cavallotto oro freno	12,70
10437254	Cavallotto porta specchio oro frizione	12,40
10437256	Cavallotto porta specchio oro freno	12,20
10437257	Cavallotto porta specchio oro freno	12,10
10437263	Cavallotto porta specchio nero frizione	11,50
10437264	Cavallotto porta specchio nero freno	11,30
10437266	Cavallotto nero freno	11,30
10437295	Cavallotto nero freno	7,20
10437296	Cavallotto silver freno/frizione	11,00
10437297	Cavallotto silver freno/frizione	9,90
10437299	Cavallotto porta specchio nero frizione	10,30
10441812	Microinterruttore	12,80
10441813	Microinterruttore cablato	17,30
10441818	Microinterruttore cablato	28,70

Code	Description	€
10441820	Microinterruttore	7,70
10441821	Microinterruttore cablato	18,50
10441826	Microinterruttore cablato	18,30
10453310	Oblo'	4,70
10459254	Perno leva	7,60
10459290	Perno leva	4,20
10459291	Perno leva	4,30
10466952	Cavallotto porta specchio silver freno	14,30
10466967	Cavallotto porta specchio silver freno	13,50
10467171	Microinterruttore cablato	19,40
10467173	Microinterruttore cablato	31,30
10467175	Microinterruttore cablato	33,40
10467178	Microinterruttore cablato	37,90
10467181	Microinterruttore cablato	44,10
10467184	Microinterruttore cablato	29,10
10467195	Microinterruttore cablato	26,50
10467196	Microinterruttore cablato	29,90
105547480	Perno leva	16,30
10571710	Registro leva	9,90
10571730	Registro leva	22,00
105877435	Kit Viti (Kit Da 12 Pcs.)	13,00
10998240	Cavallotto porta specchio nero frizione	10,30
110270443	Tappo + membrana	12,20
110270478	Tappo + membrana	13,90
110270482	Tappo + membrana	13,80
110270483	Tappo + membrana	13,00
110271110	Tappo + membrana	8,10
110353053	Cuffia parapolvere	14,00
110353060	Cuffia parapolvere	6,30
110426628	Puntalino leva frizione MX	8,70
110437213	Cavallotto porta specchio nero freno/friz.	15,40
110437227	Cavallotto nero freno/frizione	8,00
110437228	Cavallotto porta specchio nero freno	19,30
110437274	Cavallotto porta specchio nero frizione	18,10
110437292	Cavallotto titanio freno/frizione	18,10
110466937	Cavallotto porta specchio silver freno	11,80
110467186	Microinterruttore cablato	32,40
110467194	Microinterruttore cablato	31,90
110477110	Membrana antiemulsione	4,40
110A47423	Kit puntalino	19,10
110B40518	Microinterruttore cablato	23,00
13935910	Attuatore frizione KTM	65,90

LEVE PER POMPE / LEVERS FOR MASTER CYLINDER

10270616	Leva nera 173/22 mm.	15,90
10270622	Leva silver 173/22 mm.	13,30
10270624	Leva silver 170/22 mm.	14,60
10270637	Leva silver 173/22 mm. regolabile	66,40
10270640	Leva nera 166/22 mm.	21,40
10270643	Leva nera 168/22 mm.	18,50
10270650	Leva nera 167/22 mm.	14,20
10270653	Leva silver 167/22 mm.	18,90
10270654	Leva silver 172/22 mm. regolabile	72,70
10270678	Leva nera 136/22 mm.	15,70
10270680	Leva silver 168/22 mm.	20,80
10270683	Leva silver 142/22 mm. regolabile	22,60
10270685	Leva nera 165/22 mm.	9,10
10270686	Leva silver 143/22 mm.	10,20
10270688	Leva silver 167/22 mm.	13,60
10459419	Leva silver 129/19 mm.	34,50
10459454	Leva nera 166/22 mm.	27,10

COMPONENTI E RICAMBI COMPONENTS AND SPARE PARTS

Code	Description	€	Code	Description	€
10459455	Leva silver 166/20 mm.	27,10	20294512	P2108N nera int. 88 mm.	176,00
10459476	Leva nera 150/20 mm.	36,60	20355640	P2F08 DX nera i 108 mm.	160,00
10459478	Leva silver 129/20 mm.	34,60	20355641	P2F08 SX nera int.108 mm.	160,00
10459494	Leva silver 129/18 mm.	30,00	20516143	P2.32F oro int. 84 mm.	102,00
10459495	Leva silver 134/18 mm.	31,40	20516151	P2.32F nera int. 84 mm.	101,00
10459497	Leva silver 128/17 mm.	60,50	20516171	P2.32F SX nera int. 84	105,00
10489420	Leva nera 155/22 mm.	17,30	20516181	P2.32F DX nera int. 84	106,00
10489431	Leva silver 167/22 mm.	19,00	20516183	P2.32F DX nera int. 84	98,00
10489432	Leva nera 167/22 mm.	29,90	20516186	P2.32F silver int.84 mm.	99,00
10489440	Leva silver 147/22 mm.	39,80	20680011	P4 30/34F SX oro int.65	288,00
10489480	Leva nera 162/22 mm.	49,60	20695012	P2.32G SX nera int.84 mm	162,00
10489481	Leva silver 162/22 mm.	57,00	20695020	P2.32G DX nera int. 84 mm	145,00
10489482	Leva bronzo 173/22 mm. regolabile	48,40	20695022	P2.32G DX nera int. 84 mm	162,00
10489484	Leva silver 147/22 mm. regolabile	66,70	20695150	P2.34C SX oro int. 84 mm.	142,00
10523137	Leva silver 167/22 mm. regolabile	130,10	20696011	P2.30B SX oro int. 52 mm.	112,00
10523160	Leva silver 197/19 mm. regolabile	130,10	20785011	P4.34A SX oro int. 65 mm.	298,00
10523161	Leva nera 196,5/22 mm. regolabile	102,70	20785021	P4.34A DX oro int. 65 mm.	298,00
10523170	Leva silver 197/19 mm. regolabile	130,10	20834311	P4.34B SX oro int. 100 mm.	365,00
10523171	Leva silver 197/17,5 mm. regolabile	130,10	20834321	P4.34B DX oro int.100 mm.	365,00
10950056	Leva silver 176/24 mm. regolabile	73,80	20834338	P4.34B SX silver int.100 mm.	365,00
10950057	Leva silver 173/24 mm. regolabile	68,00	20834341	P4.34B DX silver int.100 mm.	365,00
10950084	Leva silver 180/22 mm. regolabile	42,70	20834351	P4.34B SX nera int.100 mm.	365,00
10950092	Leva silver 171/24 mm. regolabile	81,30	20834361	P4.34B DX nera int.100 mm.	365,00
10950093	Leva silver 173/22 mm. regolabile	75,70	20923010	P4 30/34F SX oro int.65	262,00
10998510	Leva nera 160/24 mm.	30,00	20923020	P4 30/34F DX oro int.65	262,00
110270606	Leva silver 122/18 mm.	46,10	20997030	P4.32K SX silver int.100	248,00
110270627	Leva silver 125/18 mm. regolabile	46,00	20997040	P4.32K DX silver int.100	248,00
110270628	Leva silver 125/18 mm. regolabile	46,10	22A36013	PF2.24 SX silver int.90	227,00
110270681	Leva silver 160/22 mm.	15,60	22C60910	PF 24 A silver int. 90,5	258,00
110459404	Leva hot starter	6,60	22520030	PF2 28 D SX silver int.60	154,00
110459407	Leva silver 166,5/22 mm.	35,80	22554921	PF 32 A DX silver int.70 mm.	171,00
110459494	Leva silver 129/18 mm.	33,80	22555057	PF34B SX silver int.70 mm.	188,00
110950007	Leva silver 165/24 mm. regolabile	68,10	22555061	PF34B DX Silver Int.135,5	201,00
110950050	Leva silver 181/22 mm. regolabile	75,00	22555065	PF34B DX silver int.144	238,00
LEVE PER POMPE POSTERIORI / LEVERS FOR REAR MASTER CYLINDER			22555598	PF30/32 A SX silver int. 95 mm.	195,00
10278820	Leva nera per pompa post.	33,90	22593032	PF2.28 D SX silver int.60	153,00
PINZE / BRAKE CALIPERS			22593060	PF 2.28 D SX silver int.90	191,00
20B69012	M4.32 B SX nera int.100	243,00	22593069	PF 2.28 D SX silver interasse 95 mm.	185,00
20B69018	M4.32 B SX nera int. 100	243,00	22847003	PF 26 B DX siver int. 90,5	258,00
20B69028	M4.32 B DX nera int. 100	243,00	22847019	PF 26 B DX silver int.90,5	258,00
20B69034	M4.32 B SX oro int.100	243,00	PINZE SPECIALE EDITION / BRAKE SPECIAL EDITION		
20B69044	M4.32 B SX oro int. 100	243,00	20516538	P4 30/34 SX nera int.40 bandiera tric.	308,00
20B69071	M4.32 B SX titanio int.100	243,00	20516548	P4 30/34 DX nera int.40 bandiera tric.	308,00
20B69073	M4.32 B SX titanio int.100	243,00	20516574	P4 30/34 SX oro int.40 logo rosso	199,00
20B69074	M4.32 B SX titanio int.100	243,00	20516578	P4 30/34 SX nera int.40 logo rosso	218,00
20B69083	M4.32 B DX titanio int.100	243,00	20516579	P4 30/34 SX titanio int.40 logo rosso	216,00
20B69084	M4.32 B DX titanio int.100	243,00	20516584	P4 30/34 DX oro int.40 logo rosso	199,00
20B85111	P2.32 K DX oro int.84 mm.	145,00	20516588	P4 30/34 SX nera int.40 logo rosso	218,00
20B85120	P2.32 K SX oro int.84 mm.	145,00	20516589	P4 30/34 DX titanio int.40 logo rosso	216,00
20B85163	P2.32 K DX nera int.84 mm.	145,00	20B85251	P34 SX nera int.84 mm logo rosso	137,00
20B85210	P34 E SX oro int.84 mm.	127,00	20B85273	P34 SX titanio int.84 mm logo rosso	175,00
20B85230	P34 E SX silver int.84 mm.	127,00	20B85283	P34 DX titanio int.84 mm logo rosso	175,00
20B85252	P34 E SX nera int.84 mm.	127,00	RICAMBI PINZE / BRAKE CALIPERS SPARE PARTS		
20B85262	P34 E DX nera int.84 mm.	127,00	04295410	Bustina grasso da 3 OZ.	5,50
20B85270	P34 E SX titanio int.84 mm.	127,00	05150210	Tappo parapolvere (kit da 20 pcs.)	10,10
20B85271	P34 E SX titanio int.84 mm.	163,00	05150220	Tappo parapolvere (kit da 20 pcs.)	15,50
20B85280	P34 E DX titanio int.84 mm.	127,00	05208711	Spurgo (M6)	6,30
20200611	P30C oro int. 43. mm.	101,00	05208712	Spurgo (M6) zincato bronzo	4,70
20200710	P32A silver int.43 mm.	111,00			
20200711	P32A silver int.43 mm.	115,00			

COMPONENTI E RICAMBI / COMPONENTS AND SPARE PARTS



Code	Description	€
05324611	Spurgo (M10)	3,80
05324614	Spurgo (M8)	4,10
05338710	Spurgo (M10)	5,60
05338730	Spurgo (M10)	4,70
05338752	Spurgo (M8)	5,50
05338753	Spurgo (M6)	7,40
05380510	Spurgo (M6)	4,80
05380512	Spurgo (M6)	6,90
05454218	Copiglia (kit da 20 pcs)	14,40
05474710	Kit guarnizioni pinze SL2 28	19,20
20225220	Pistoni	18,90
20225590	Molla pastiglie	13,40
20268820	Coperchio	11,20
20274110	Guarnizioni	11,50
20274160	Guarnizioni	10,90
20274170	Guarnizioni	12,00
20274210	Perni	7,80
20274220	Perni	21,10
20279910	Guarnizioni	13,50
20279911	Guarnizioni + pistoni	34,90
20279960	Guarnizioni	39,30
20280010	Perni	6,20
20280011	Perni	7,80
20280030	Perni	5,70
20280040	Perni	4,40
20280050	Perni	5,00
20280060	Perni	5,80
20280061	Perni	5,60
20280064	Perni	7,10
20320433	Perni	5,40
20320435	Perni	5,10
20325410	Coperchio	7,30
20325430	Coperchio	3,20
20338610	Perni	8,90
20393810	Coperchio	3,00
20394230	Perni + Copiglie	11,30
20397420	Perni	5,10
20397460	Perni	10,40
20419685	Molla antivibrazioni	5,30
20468320	Molla antivibrazioni + lamierino	5,80
20468322	Molla antivibrazioni	4,90
20468324	Molla antivibrazioni	6,90
20468325	Molla antivibrazioni	8,70
20468327	Molla antivibrazioni + lamierino	10,80
20468330	Molla antivibrazioni	6,60
20511611	Perni + copiglie	13,50
210467198	Microinterruttore cablato	22,60
22464530	Guida	14,10
22474610	Cuffia parapolvere	27,90
22474614	Cuffia parapolvere	10,20
22484956	Molla perno	22,30
22508920	Perni	9,10
22508921	Perni	7,60
22508922	Perni	8,70
22508923	Perni	8,50
22508925	Perni	7,60
22508926	Perni	7,60
22508932	Perni	16,70
22508940	Perni	15,50
122508930	Perni	6,50

Code	Description	€
ACCESSORI / ACCESSORIES		
99000515	Zaino brembo	27,50
99000530	Cappellino BREMBO RACING nero	16,50
99015110	Polsino nero logo BREMBO grande	10,00
99863766	Polsino nero logo BREMBO piccolo	10,00

RACING





TRACK

CC	Modello Model	Anno Year	Ø OE	Supersport Code	Upgrade Ø 320	€	T-Drive Code	Upgrde Ø 320	€
----	------------------	--------------	------	--------------------	------------------	---	-----------------	-----------------	---

DISCHI Supersport e T-Drive, FASCIA FRENANTE H. 34 mm - Th. 5,5 mm Supersport & T-Drive BRAKE DISCS ROTOR H. 34 mm - Th. 5,5 mm

APRILIA

1000	RSV All models	'98→'08	Ø320	2089737.25	-	498,00	208A985.25	-	598,00
1000	RSV4 All models	'09→	Ø320	2089737.25	-	498,00	208A985.25	-	598,00
1000	RSV4 All models	'17→	Ø330	208B859.25	-	588,00	208C89025	-	698,00
1000	Tuono All models	'02→'09	Ø320	2089737.25	-	498,00	208A985.25	-	598,00
1000	Tuono V4 All models	'11→'14	Ø320	2089737.25	-	498,00	208A985.25	-	598,00
1100	Tuono V4 All models	'15→'16	Ø320	2089737.25	-	498,00	208A985.25	-	598,00
1100	Tuono V4 All models	'17→	Ø330	208B859.25	-	588,00	208C89025	-	698,00

BENELLI

	Tutti i modelli	-	Ø320	2089737.10	-	498,00	208A985.10	-	598,00
--	-----------------	---	------	------------	---	--------	------------	---	--------

BIMOTA

1000	BB3	'14→	Ø320	2089737.10	-	498,00	208A985.10	-	598,00
------	-----	------	------	------------	---	--------	------------	---	--------

BMW

1000	HP4 *	'13→	Ø320	2089737.53	-	498,00	208A985.53	-	598,00
1000	S 1000 RR **	'09→	Ø320	2089737.51	-	588,00	-	-	-
1000	S 1000 RR (con ruote HP4) **	'15→'18	Ø320	2089737.54	-	588,00	208A985.53	-	598,00
1000	S 1000 RR (con ruote forgiate * o in carbonio)	'19→	Ø320	2089737.67	-	498,00	208A985.67	-	598,00
1000	S 1000 RR (con ruote fuse) **	'19→	Ø320	2089737.51	-	588,00	-	-	-

* Nottolini in alluminio ** Nottolini in acciaio

DUCATI

748	748 All models (no versione R)	'98→'02	Ø320	2089737.10	-	498,00	208A985.10	-	598,00
749	749 All models	'03→'07	Ø320	2089737.11	-	498,00	208A985.11	-	598,00
803	Scrambler (All models)	'15→	Ø330	108B859.58	-	294,00	-	-	-
821	Hypermotard, SP	'13→	Ø320	2089737.36	-	498,00	208A985.36	-	598,00
821	Hyperstrada	'13→	Ø320	2089737.36	-	498,00	208A985.36	-	598,00
848	848 EVO	'08→'13	Ø320	2089737.11	-	498,00	208A985.11	-	598,00
848	848 EVO Corse S.E.	'12→'13	Ø330	208B859.11	-	588,00	208C89011	-	698,00
848	Streetfighter, S	'12→	Ø320	2089737.36	-	498,00	208A985.36	-	598,00
899	899 Panigale	'14→	Ø320	2089737.11	-	498,00	208A985.11	-	598,00
916	916 All Models	'94→'98	Ø320	2089737.10	-	498,00	208A985.10	-	598,00
916	Monster S4	'01→'03	Ø320	2089737.10	-	498,00	208A985.10	-	598,00
939	Hypermotard 939	'16→	Ø320	2089737.36	-	498,00	208A985.36	-	598,00
939	Hyperstrada 939	'16→	Ø320	2089737.36	-	498,00	208A985.36	-	598,00
955	955 Panigale V2	'20→	Ø320	2089737.11	-	498,00	208A985.11	-	598,00
959	959 Panigale	'16→	Ø320	2089737.11	-	498,00	208A985.11	-	598,00
996	996 All models (no versione R)	'99→'01	Ø320	2089737.10	-	498,00	208A985.10	-	598,00
998	998 All models (no versione R)	'02→'03	Ø320	2089737.10	-	498,00	208A985.10	-	598,00
998	999 All models	'03→'07	Ø320	2089737.11	-	498,00	208A985.11	-	598,00
1000	Desmosedici RR	'08→	Ø330	208B859.11	-	588,00	208C89011	-	698,00
1000	Monster S2R	'06→'07	Ø320	2089737.10	-	498,00	208A985.10	-	598,00
1000	Monster S4R	'03→'06	Ø320	2089737.10	-	498,00	208A985.10	-	598,00
1000	Monster S4 RS	'06→'07	Ø320	2089737.11	-	498,00	208A985.11	-	598,00
1098	1098 All models	'07→'08	Ø330	208B859.11	-	588,00	208C89011	-	698,00
1098	Streetfighter, S	'09→	Ø330	208B859.11	-	588,00	208C89011	-	698,00
1103	Streetfighter V4 All models	'20	Ø330	208B859.11	-	588,00	208C89011	-	698,00
1103	Panigale V4	'18→	Ø330	208B859.11	-	588,00	208C89011	-	698,00
1100	Monster All models	'09→'13	Ø320	2089737.36	-	498,00	208A985.36	-	598,00
1100	Monster S	'09→'10	Ø320	2089737.11	-	498,00	208A985.11	-	598,00
1198	1098 R, Bayliss	'09	Ø330	208B859.11	-	588,00	208C89011	-	698,00
1198	1198 All models	'09→'11	Ø330	208B859.11	-	588,00	208C89011	-	698,00

CC	Modello Model	Anno Year	Ø OE	Supersport Code	Upgrade Ø 320	€	T-Drive Code	Upgrde Ø 320	€
1199	1199 Panigale All models	'12→	Ø330	208B859.11	-	588,00	208C890.11	-	698,00
1199	1199 Superleggera	'14→	Ø330	208B859.11	-	588,00	208C890.11	-	698,00
1200	Monster	'14→	Ø320	2089737.36	-	498,00	208A985.36	-	598,00
1200	Monster All models	'14→	Ø330	208B859.36	-	588,00	208C890.36	-	698,00
1200	Multistrada	'10→	Ø320	2089737.36	-	498,00	208A985.36	-	598,00
1200	Multistrada S All models	'15→	Ø330	208B859.36	-	588,00	208C890.36	-	698,00
1200	Multistrada S All models	'13→'14	Ø320	2089737.36	-	498,00	208A985.36	-	598,00
1299	1299 Panigale All models	'15→	Ø330	208B859.11	-	588,00	208C890.11	-	698,00

HONDA

600	CBR RR, ABS	'03→	Ø310	2089737.46	.12	498,00	208A985.46	.12	598,00
1000	CB R, ABS	'08→	Ø310	2089737.46	.12	498,00	208A985.46	.12	598,00
1000	CBR 1000 RR	'04→'05	Ø310	2089737.46	.12	498,00	208A985.46	.12	598,00
1000	CBR 1000 RR	'06→'07	Ø320	2089737.12	-	498,00	208A985.12	-	598,00
1000	CBR 1000 RR	'08→	Ø320	2089737.45	-	498,00	208A985.45	-	598,00
1000	CBR 1000 RR / SP1	'17→	Ø320	2089737.64	-	498,00	208A985.64	-	598,00
1000	CBR 1000 RR SP2	'17→	Ø320	2089737.65	-	498,00	208A985.65	-	598,00
1000	CBR 1000 RR-R + SP	'20→	Ø330	208B859.69	-	588,00	208C890.69	-	698,00
1000	VTR SP1, SP2	'00→'04	Ø320	2089737.12	-	498,00	208A985.12	-	598,00

KAWASAKI

250	Ninja 250	'08→'12	Ø300	1089737.49	-	249,00	-	-	-
300	Ninja 300	'13→	Ø300	1089737.57	-	249,00	-	-	-
300	Ninja 300	'13→	Ø290	08A64231	-	244,44	-	-	-
400	Ninja 400	'18→	Ø310	08A64234	-	244,44	-	-	-
600	ZX-6R, ZX-6RR	'05→	Ø300	2089737.14	.22	498,00	-	.22	598,00
636	ZX-6R 636 NINJA	'05→'06	Ø300	2089737.14	.22	498,00	-	.22	598,00
636	ZX-6R 636, ABS	'13→	Ø310	2089737.34	.22	498,00	208A985.34	.22	598,00
750	Z 750 ABS	'07→	Ø300	2089737.14	.22	498,00	-	.22	598,00
750	Z 750 R, ABS	'11→'12	Ø300	2089737.14	.22	498,00	-	.22	598,00
800	Z 800, E, ABS	'13→	Ø310	2089737.34	.22	498,00	208A985.34	.22	598,00
1000	Z1000, ABS	'07→	Ø300	2089737.14	.22	498,00	-	.22	598,00
1000	Z1000 SX, ABS	'11→'13	Ø300	2089737.14	.22	498,00	-	.22	598,00
1000	ZX-10R, ABS	'04→'07	Ø300	2089737.14	.22	498,00	-	.22	598,00
1000	ZX-10R, ABS	'08→'15	Ø310	2089737.34	.22	498,00	-	.22	598,00
1000	ZX-10R ABS	'16→'18	Ø330	208B859.22	-	588,00	208C890.22	-	698,00
1000	ZX-10RR ABS	'17→	Ø330	208B859.61	-	588,00	208C890.61	-	698,00
1000	H2, H2R	'15→	Ø330	208B859.59	-	588,00	-	-	-
1400	GTR	'07→'11	Ø310	2089737.34	.22	498,00	208A985.34	.22	598,00
1400	ZZR, ABS	'06→	Ø310	2089737.34	.22	498,00	208A985.34	.22	598,00
1400	ZZR Performance Sport	'16→	Ø310	2089737.34	.22	498,00	208A985.34	.22	598,00

KTM

390	390 RC	'16→	Ø298	08A64232	-	244,44	-	-	-
990	Superduke, R	'05→'11	Ø320	2089737.10	-	498,00	208A985.10	-	598,00
1190	RC8 All Models	'08→	Ø320	2089737.10	-	498,00	208A985.10	-	598,00
1290	Superduke, R	'14→	Ø320	2089737.24	-	498,00	208A985.24	-	598,00

MV AGUSTA

675	Brutale	'13→	Ø320	2089737.47	-	498,00	208A985.47	-	598,00
675	F3	'12→	Ø320	2089737.47	-	498,00	208A985.47	-	598,00
675	F3 Serie Oro	'12→'13	Ø320	2089737.28	-	498,00	208A985.28	-	598,00
750	Brutale	'03→'05	Ø310	2089737.27	28	498,00	208A985.27	28	598,00
750	F4	'99→'03	Ø310	2089737.27	28	498,00	208A985.27	28	598,00
800	Brutale	'13→	Ø320	2089737.47	-	498,00	208A985.47	-	598,00
800	Dragster	'14→	Ø320	2089737.47	-	498,00	208A985.47	-	598,00
800	F3	'12→'13	Ø320	2089737.47	-	498,00	208A985.47	-	598,00
800	F3 Ago, Serie Oro	'12→	Ø320	2089737.28	-	498,00	208A985.28	-	598,00
800	Rivale	'14	Ø320	2089737.47	-	498,00	208A985.47	-	598,00
910	Brutale R, Italia	'05→'08	Ø320	2089737.28	-	498,00	208A985.28	-	598,00
910	Brutale, S	'05→'08	Ø310	2089737.27	28	498,00	208A985.27	28	598,00



CC	Modello Model	Anno Year	Ø OE	Supersport Code	Upgrade Ø 320	€	T-Drive Code	Upgrde Ø 320	€
989	Brutale R	'08	Ø310	2089737.27	28	498,00	208A985.27	28	598,00
1000	F4 S	'04→'06	Ø310	2089737.27	28	498,00	208A985.27	28	598,00
1000	F4, R, RR	'13→	Ø320	2089737.28	-	498,00	208A985.28	-	598,00
1000	F4 1000 312R	'07→	Ø320	2089737.28	-	498,00	208A985.28	-	598,00
1000	F4 Freccie Tricolori	'10→'12	Ø320	2089737.28	-	498,00	208A985.28	-	598,00
1000	F4 R, RR, S	'06→'12	Ø320	2089737.28	-	498,00	208A985.28	-	598,00
1078	Brutale 1078 RR	'08	Ø320	2089737.28	-	498,00	208A985.28	-	598,00
1078	F4 312RR	'07→'08	Ø320	2089737.28	-	498,00	208A985.28	-	598,00
1090	Brutale RR	'10→'13	Ø320	2089737.28	-	498,00	208A985.28	-	598,00
1090	Brutale Corsa	'13	Ø320	2089737.28	-	498,00	208A985.28	-	598,00

SUZUKI

600	GSR	'06→'10	Ø310	2089737.35	-	498,00	208A985.35	-	598,00
600	GSX-R	'97→'03	Ø320	2089737.15	-	498,00	208A985.15	-	598,00
600	GSX-R	'04→'05	Ø300	2089737.16	-	498,00	-	-	-
600	GSX-R	'06→'07	Ø310	2089737.17	.26	498,00	208A985.17	.26	598,00
600	GSX-R	'08→	Ø310	2089737.32	.33	498,00	208A985.32	.33	598,00
750	GSX-R	'96→'03	Ø320	2089737.15	-	498,00	208A985.15	-	598,00
750	GSX-R	'04→'05	Ø300	2089737.16	-	498,00	-	-	-
750	GSX-R	'06→'07	Ø310	2089737.17	.26	498,00	208A985.17	.26	598,00
750	GSX-R	'08→	Ø310	2089737.32	.33	498,00	208A985.32	.33	598,00
750	GSR	'11→	Ø310	2089737.35	-	498,00	208A985.35	-	598,00
1000	GSX-R	'01→'02	Ø320	2089737.15	-	498,00	208A985.15	-	598,00
1000	GSX-R	'03→'04	Ø300	2089737.16	-	498,00	-	-	-
1000	GSX-R	'05→'08	Ø310	2089737.17	.26	498,00	208A985.17	.26	598,00
1000	GSX-R	'09→	Ø310	2089737.32	.33	498,00	208A985.32	.33	598,00
1000	GSX-R	'17→	Ø320	2089737.33	-	498,00	208A985.33	-	598,00
1000	GSX-R R	'17→	Ø320	2089737.33	-	498,00	208A985.33	-	598,00
1000	TL R	'98→'03	Ø320	2089737.15	-	498,00	208A985.15	-	598,00
1000	TL S	'97→'01	Ø320	2089737.15	-	498,00	208A985.15	-	598,00
1300	B-KING	'08→'10	Ø310	2089737.35	-	498,00	208A985.35	-	598,00
1300	GSX-R Hayabusa	'99→'07	Ø320	2089737.15	-	498,00	208A985.15	-	598,00
1300	GSX-R Hayabusa	'08→'12	Ø310	2089737.35	-	498,00	208A985.35	-	598,00

TRIUMPH

675	Daytona, R	'13→	Ø310	2089737.56	-	498,00	208A985.56	-	598,00
675	Daytona, R	'06→'11	Ø310	2089737.30	-	498,00	208A985.30	-	598,00
675	Speed Triple	'07→'09	Ø310	2089737.30	-	498,00	208A985.30	-	598,00
675	Street Triple, R	'07→'12	Ø310	2089737.30	-	498,00	208A985.30	-	598,00
675	Street Triple, R	'13→	Ø310	2089737.56	-	498,00	208A985.56	-	598,00
1050	Speed Triple S	'05→'07	Ø320	2089737.23	-	498,00	208A985.23	-	598,00
1050	Speed Triple	'08→	Ø320	2089737.37	-	498,00	208A985.37	-	598,00
1050	Tiger, ABS	'07→'12	Ø320	2089737.23	-	498,00	208A985.23	-	598,00

YAMAHA

300	R3	'15→	Ø298	08A64230	-	244,44	-	-	-
600	FZ6 S2 - Fazer	'07→'08	Ø300	2089737.19	-	498,00	-	-	-
600	FZ6 - Fazer	'04→'08	Ø300	2089737.19	-	498,00	-	-	-
600	YZF R Thundercat	'96→'04	Ø300	2089737.18	-	498,00	-	-	-
600	YZF R6	'99→'02	Ø300	2089737.18	-	498,00	-	-	-
600	YZF R6	'03→'04	Ø300	2089737.19	-	498,00	-	-	-
600	YZF R6	'05→	Ø310	2089737.20	.21	498,00	208A985.20	.21	598,00
600	YZF R6	'17→	Ø320	2089737.48	-	498,00	208A985.48	-	598,00
660	MT-03	'06→'11	Ø300	2089737.19	-	498,00	-	-	-
750	YZF R/SP	'93→'97	Ø320	2089737.10	-	498,00	208A985.10	-	598,00
800	Fazer 8	'10→'12	Ø310	2089737.20	.21	498,00	208A985.20	.21	598,00
800	FZ 8	'10→'13	Ø310	2089737.20	.21	498,00	208A985.20	.21	598,00
1000	FZ1	'06→'11	Ø320	2089737.21	-	498,00	208A985.21	-	598,00
1000	FZ1-S Fazer	'06→'12	Ø320	2089737.21	-	498,00	208A985.21	-	598,00
1000	YZF R Thunderace	'96→'98	Ø300	2089737.18	-	498,00	-	-	-
1000	YZF R1	'98→'03	Ø300	2089737.18	-	498,00	-	-	-

CC	Modello Model	Anno Year	Ø OE	Supersport Code	Upgrade Ø 320	€	T-Drive Code	Upgrde Ø 320	€
1000	YZF R1	'04→'06	Ø320	2089737.21	-	498,00	208A985.21	-	598,00
1000	YZF R1 SP	'06→	Ø320	2089737.24		498,00	-	-	-
1000	YZF R1	'07→'14	Ø310	2089737.20	.21	498,00	208A985.20	.21	598,00
1000	YZF R1, R1M	'15→	Ø320	2089737.48	-	498,00	208A985.48	-	598,00

* Ø 298 x spessore 4,5 mm come richiesto dal regolamento del Campionato WSSP300

Code	Description	€ cad.	Note
------	-------------	--------	------

DISCHI "PISTA BASSA" TRASCINAMENTO T-DRIVE (fascia frenante H. 30 mm-Th 6,75 mm) "PISTA BASSA" DISCS T-DRIVE SYSTEM (discs rotor H. 30 mm-Th 6,75 mm)

APRILIA

08C86925	Ø 320 x 6,75 (6 fori 64 x 80) (Intercambiabile all'originale)	689,00	RSV / RSV4 / TUONO
-----------------	---------------------------------------------------------------	--------	--------------------

BMW

08C86953	Ø 320 x 6,75 (6 fori 64 x 80) (Intercambiabile all'originale)	689,00	S1000RR HP4 '15→'18 con ruote Alluminio forgiato
08C86967	Ø 320 x 6,75 (6 fori 80 x 96) (Intercambiabile all'originale)	689,00	S1000RR HP4 '19→ con ruote Carbonio

DUCATI

08C86911	Ø 320 x 6,75 (5 fori 72 x 90) (Intercambiabile all'originale)	689,00	1098/1198/1199/1299/Dsedici Panigale V4
08C86911	Ø 320 x 6,75 (5 fori 72 x 90) (Intercambiabile all'originale)	689,00	749 / 999 / 848 / 899 / 959
08C86925	Ø 320 x 6,75 (6 fori 64 x 80) (Intercambiabile all'originale)	689,00	888 / 748 / 916 / 996 / 998
08C86936	Ø 320 x 6,75 (5 fori 72 x 90)	689,00	999RS / 1098RS / 1198RS (SBK vers. clienti)

HONDA

08C86962	Ø 320 x 6,75 (6 fori 94 x 110) (Intercambiabile all'originale - No ABS)	689,00	CBR1000 RR '08→'16
08C86963	Ø 320 x 6,75 (6 fori 94 x 110) (Intercambiabile all'originale)	689,00	CBR600 '03-'12, VTR SP1 / SP2
08C86964	Ø 320 x 6,75 (5 fori 94 x 110) (Intercambiabile all'originale - Ok ABS)	689,00	CBR1000 RR '17→'19 / SP '17→'19
08C86965	Ø 320 x 6,75 (6 fori 74 x 90) (Intercambiabile all'originale - Ok ABS)	689,00	CBR1000 RR SP2 '17→'19
08C86969	Ø 320 x 6,75 (6 fori 94 x 110) (Intercambiabile all'originale - Ok ABS)	689,00	CBR1000 RR-R '20 → / SP '20→

KAWASAKI

08C86922	Ø 320 x 6,75 (5 fori 80,5 x 100) (Intercambiabile all'originale)	689,00	ZX6R - RR '05→ / ZX10R '04→
08C86961	Ø 320 x 6,75 (5 fori 70 x 90) (Intercambiabile all'originale)	689,00	ZX10-RR '17→

KTM

08C86925	Ø 320 x 6,75 (6 fori 64 x 80) (Intercambiabile all'originale)	689,00	RC8 '08→/ RC8 R '10→
-----------------	---------------------------------------------------------------	--------	----------------------

SUZUKI

08C86933	Ø 320 x 6,75 (6 fori 102,2 x 120) (Intercambiabile all'originale)	689,00	GSX-R 600 '08→/ 750 '08→ 1000 '09→
08C86933	Ø 320 x 6,75 (6 fori 102,2 x 120) (Intercambiabile all'originale)	689,00	GSX-R 1000 abs '15→'16 / GSX-R \ R1000 '17→'20

YAMAHA

08C86948	Disco Ø 320 x 6,75 (5 fori 132,4 x 150) (Intercambiabile all'originale)	689,00	R6 '17→/R1 '15→/R1M '15→ MT10 '17→
-----------------	----------------------------------------------------------------------------	--------	---------------------------------------



Code	Description	€	Note
DISCHI SBK TRASCINAMENTO A BUSSOLE (fascia frenante H. 30 mm-Th 6 mm) SBK BRAKE DISCS BUSHING SYSTEM (discs rotor H. 30 mm-Th 6 mm)			
BMW			
08755019	Ø 320x6 (6 Fori 64x80) (Intercambiabile all'originale)	420,00	HP4 '13→ (ok per ruota fonica)
DUCATI			
08670321	Ø 320 x 6 (6 Fori 80 x 101,5)	420,00	851 / 888
08755018	Ø 320 x 6 (5 Fori 72 x 90)	420,00	999 RS / 1098 RS / 1198 RS (SBK vers. clienti)
08755020	Ø 320 x 6 (5 Fori 72 x 90)	420,00	1199 Panigale RS (SBK vers. clienti)
HONDA			
08670343	Ø 290x5,5 (6 Fori 58x74)	393,10	
08755017	Ø 320x6 (6 Fori 94x110) (Intercambiabile all'originale - NO ABS)	420,00	CBR 1000 RR '08→
SUZUKI			
08670366	Ø 320x6 (5 Fori 69x91)	449,93	
08715066	Ø 320x6 (5 Fori 69x91) (Intercambiabile all'originale) Intercambiabile anche con i seguenti modelli (con disco originale Ø 300mm):	393,00	GSX-R 600 '97→'03/750 '96→'03/1000 '01→'02 GSX-R 600 '04→'05/750 '04→'05/1000 '03→'04
08755015	Ø 320x6 (6 Fori 100x120) (Intercambiabile all'originale)	420,00	GSX-R 1000 ABS '15→'16 / GSX-R R1000 '17→'20
YAMAHA			
08715150	Ø 320x6 (5 Fori 132x150) (Intercambiabile all'originale)	603,88	YZF R6 '05→'16
08755021	Ø 320x6 (5 Fori 132x150) (Intercambiabile all'originale)	420,00	R6 '17→/ R1 '04→/ R1M '15→/ MT10 '17→
DISCHI MOT02 (fascia frenante H. 34 mm-Th 5,5 mm) MOTO2 BRAKE (discs rotor H. 34 mm-Th 5,5 mm)			
108973740	Ø 300x5,5 (6 Fori 64 x 80)	249,00	
108973741	Ø 300x5,5 (6 Fori 60 x 80)	249,00	
DISCHI MOT03 (fascia frenante H. 30 mm-Th 4 mm) MOTO3 BRAKE (discs rotor H. 30 mm-Th 4 mm)			
08715289	Ø 218x4 (6 Fori 60 x 80)	558,80	(sinistro)
08715290	Ø 218x4 (6 Fori 60 x 80)	558,80	(destra)
POMPE FRENO - BRAKE MASTER CYLINDERS			
110C74010	Pompa radiale PR 19x18-20 - 19RCS Corsa Corta	335,00	Int. leva variabile, corsa a vuoto regolabile
110C74030	Pompa radiale PR 15x18-20 - 15RCS Corsa Corta	335,00	Int. leva variabile, corsa a vuoto regolabile
110C74040	Pompa radiale PR 17x18-20 - 17RCS Corsa Corta	335,00	Int. leva variabile, corsa a vuoto regolabile
110A26310	Pompa radiale PR 19x18-20 - 19RCS	295,00	Interasse leva variabile
110A26320	Pompa radiale PR 15x18-20 - 15RCS - leva corta	279,00	Interasse leva variabile - per monodisco
110A26330	Pompa radiale PR 15x18-20 - 15RCS	279,00	Interasse leva variabile - per monodisco
110A26340	Pompa radiale PR 17x18-20 - 17RCS	295,00	Interasse leva variabile
110A26345	Pompa radiale PR 14x18-20 - 14RCS - Lato DX	239,00	Interasse leva variabile - per monodisco
110A26365	Pompa radiale PR 14x18-20 - 14RCS - Lato SX	239,00	Interasse leva variabile - per monodisco
10476060	Pompa radiale PR 19x20 (Forgiata)	233,00	
10476070	Pompa radiale PR 19x18 (Forgiata)	256,25	
10476080	Pompa radiale PR 16x18 (Forgiata)	256,25	Per Monodisco
10476082	Pompa radiale PR 16x18 (Forgiata - con leva corta)	222,44	Per Monodisco
XR01170	Pompa radiale PR 19x16 (Ricavata CNC)	544,54	Per pinze Bre. Rac. e applicazioni speciali
XR01171	Pompa radiale PR 19x18 (Ricavata CNC)	544,54	
XR01172	Pompa radiale PR 19x20 (Ricavata CNC)	544,54	
XR01130	Pompa radiale PR 16x16 (Ricavata CNC)	544,54	Per Monodisco
XR011B0	Pompa radiale PR 16x16 (Ricavata CNC - con leva corta)	544,54	Per Monodisco

Code	Description	€	Note
XA7G750	Pompa radiale PR 18x18 (Ricavata CNC) -	2.420,00	MotoGP-WSBK - Attacco sens. pinze EVO
XA7G7G0	Pompa radiale PR 19x18 (Ricavata CNC)	1.898,60	MotoGP-WSBK - Att. sens. di pressione
985760	Pompa "Pollice" PS 13 (per mano sinistra)	1.657,66	Per pinza posteriore, comb. 963720 o 30
985770	Pompa "Pollice" PS 11 (per mano sinistra)	1.657,66	Per pinza posteriore, comb. 963710
985780	Pompa "Pollice" PS 13 (per mano sinistra)	1.657,66	Per pinza posteriore, comb. 963720 o 30

POMPE FRIZIONE - CLUTCH MASTER CYLINDERS

110C74050	Pompa radiale PR 16x16-18 - 16RCS Corsa Corta	335,00	Int. leva variabile, corsa a vuoto regolabile
110A26350	Pompa radiale PR 16x16-18 - 16RCS	295,00	Interasse leva variabile
110A26355	Pompa radiale PR 17x16-18 - 17RCS	295,00	Interasse leva variabile
110A26370	Pompa radiale PR 19x18-20 - 19RCS	295,00	Interasse leva variabile
XA2N650	Pompa radiale PR 16x19	1.468,21	(Ricavata CNC)
XR01150	Pompa radiale PR 16x16	497,29	(Ricavata CNC)
XR01151	Pompa radiale PR 16x18	497,29	(Ricavata CNC)
XR01155	Pompa radiale PR 19x18	497,29	(Ricavata CNC)

POMPE FRENO POSTERIORI - REAR BRAKE MASTER CYLINDERS

963710	Pompa PS 11 (uscita fluido freni parte superiore)	426,25	Da utilizzare solo con pompa pollice
963720	Pompa PS 13 (uscita fluido freni parte superiore)	426,25	Da utilizzare solo con pompa pollice
963730	Pompa PS 14 (uscita fluido freni parte posteriore)	426,25	Da utilizzare solo con pompa pollice
XA52130	Pompa PS 13 CNC con serbatoio inc. (serb. tondo)	836,00	Uscita per sensore di pressione
XA52140	Pompa PS 13 CNC con serbatoio inc. (serb. rettangolare)	836,00	

RICAMBI LEVE POMPE RCS - RCS M/C LEVERS

110A26378	Mezza leva con intaglio pompe RCS lato freno	52,80	
110A26379	Mezza leva con intaglio pompe RCS lato frizione	52,80	
110A26383	Leva frizione completa 19RCS - 17RCS	139,00	Lato frizione
110A26394	Mezza leva 19RCS-17RCS-16RCS + frizione meccanica	37,99	Lato frizione
110A26395	Leva frizione completa 16RCS	139,00	Lato frizione
110A26396	Mezza leva corta pompe RCS	37,99	
110A26397	Leva freno completa 15RCS corta	139,00	
110A26398	Mezza leva 19RCS - 17RCS - 15RCS lunga	40,00	
110A26399	Leva freno completa 19RCS - 17RCS - 15RCS lunga	139,00	
110C74098	Mezza leva RCS CorsaCorta	48,20	
110C74099	Leva freno completa RCS Corsa Corta	100,00	Non fornita - implica revisione pompa
110C740R4	Mezza leva RCS CorsaCorta "Racing Shape"	50,00	

RICAMBI LEVE POMPE RADIALI - RADIAL M/C LEVERS

104881	Leva curva per pompa radiale interasse 16	29,99	CNC
985706	Leva di ricambio per pompa pollice	244,00	
10459460	Leva standard per pompa radiale interasse 20	41,19	Leva fissa
10459461	Leva standard per pompa radiale interasse 18	41,19	Leva fissa
10726431	Leva corta per pompa radiale interasse 20	37,88	Leva fissa
10726432	Leva corta per pompa radiale interasse 18	37,88	Leva fissa
10726433	Leva corta per pompa radiale interasse 16	37,88	Leva fissa
110523115	Leva curva per pompa freno interasse 20	80,56	Leva snodata
110523116	Leva curva per pompa freno interasse 18	81,62	Leva snodata
110523117	Leva corta per pompa freno interasse 16	79,02	Leva snodata
110726435	Guidaleva per pompa XR - interasse 20 mm	47,37	Freno e friz. - Comp. pompe 104760...
110726436	Guidaleva per pompa XR - interasse 18 mm	47,37	Freno e friz. - Comp. pompe 104760...
110726437	Guidaleva per pompa XR - interasse 16 mm	47,37	Freno e friz. - Comp. pompe 104760...
X98A7E1	Mezza leva standard per pompa XR	75,77	Freno e friz. - Comp. pompe 104760...
X98A7E2	Mezza leva corta per pompa XR	75,77	Freno e friz. - Comp. pompe 104760...
X98A7E3	Mezza leva dritta per pompa XR	75,77	Freno e friz. - Comp. pompe 104760...

LEVE FRIZIONI MECCANICHE - MECHANICAL CLUTCH LEVERS

110B01265	Leva frizione meccanica "tipo RCS"	140,00	Per bracciale originale Kawasaki
110B01275	Leva frizione meccanica "tipo RCS"	140,00	Per bracciale originale BMW S1000RR
110B01285	Leva frizione meccanica "tipo RCS"	140,00	Per bracciale orig. Honda CBR600/CBR1000
110B01295	Leva frizione meccanica "tipo RCS"	140,00	Per bracciale orig. Aprilia/Suzuki/Yamaha

Code	Description	€	Note
------	-------------	---	------

ACCESSORI POMPE FRENO - MASTER CYLINDERS ACCESSORIES

X9849B0	Remote adjuster (con coppia conica) - senza supporto (vedi 110A26374)	639,39	Dedicato a pompe XR e forgiate
X98A7C0	Remote adjuster - senza supporto (vedi 110A26374)	217,87	Spec. per pompa XA7G7G0 e XA7G750
205710	Remote adjuster L= 565 - no supporto (vedi 110A26374)	142,00	
205711	Remote adjuster L= 715 - no supporto (vedi 110A26374)	142,00	
205712	Remote adjuster L= 625 - no supporto (vedi 110A26374)	142,00	
01538620	Molletta tubo fluido freni	0,30	
06537503	Tubo fluido freni (1m)	13,20	
110A26374	Supporto remote adjuster	127,00	Utilizzabile per tutti i remote adjuster
110A26375	Kit montaggio serbatoio pompa RCS freno	60,00	Serbatoio fumè
110A26376	Kit montaggio serbatoio pompa RCS frizione	51,00	Serbatoio fumè
110A26384	Remote adjuster pompe freno RCS	205,00	
110A26385	Kit montaggio serbatoio pompa RCS freno	48,00	
110A26386	Kit montaggio serbatoio pompa RCS frizione	39,00	
110A26387	Cavallotto CNC pompe RCS	28,50	Freno e frizione
110A26380	Cavallotto portaspecchio lato DX pompe RCS	37,00	Filettatura M8x1,25
110A26381	Cavallotto portaspecchio lato SX pompe RCS	37,00	Filettatura M8x1,25
110A26390	Cavallotto portaspecchio lato DX pompe RCS	37,00	Filettatura M10x1,25
110A26391	Cavallotto portaspecchio lato SX pompe RCS	37,00	Filettatura M10x1,25
110C74080	Cavallotto portaspecchio lato DX pompe RCS Corsa Corta	45,00	Filettatura M8x1,25
110C74081	Cavallotto portaspecchio lato SX pompe RCS Corsa Corta	45,00	Filettatura M8x1,25
110C74090	Cavallotto portaspecchio lato DX pompe RCS Corsa Corta	45,00	Filettatura M10x1,25
110C74091	Cavallotto portaspecchio lato SX pompe RCS Corsa Corta	45,00	Filettatura M10x1,25

RICAMBI POMPE FRENO - MASTER CYLINDER SPARE PARTS

05338760	Vite spurgo per pompe forgiate	4,37	Freno e frizione
05338763	Vite spurgo per pompe RCS	7,21	Freno e frizione
10281570	Cavallotto CNC per pompa frizioni PR16 e PR19 CNC	12,08	
10281580	Cavallotto CNC per pompa freno PR16 e PR19 CNC	10,65	
10281581	Cavallotto forgiato per pompa freno PR16 e PR19	16,36	
10459240	Perno leva PR16 e PR19	1,19	Freno e frizione
10510710	Pomello regolazione corsa leva PR16 e PR19	9,70	Freno e frizione
10511010	Barilotto perno regolazione distanza leva PR16 e PR19	39,07	Freno e frizione
110426660	Kit puntalino PR16 e PR19	30,00	Pompe forgiate + CNC Ø19
110459291	Perno leva RCS	3,08	Freno e frizione
110A26377	Kit pomello regolazione corsa leva + molletta RCS	8,57	Freno e frizione
110A26388	Cavallotto pompa RCS	16,99	Freno e frizione
110A26389	Tappo in gomma + adesivo bandiera tricolore RCS	8,99	Kit 10 pz.
110C74007	Perno leva RCS Corsa Corta	30,52	
110C74088	Cavallotto RCS Corsa Corta	31,50	
110C74089	Tappo in gomma + adesivo bandiera tricolore RCS Corsa Corta	10,27	
A51101046	Spina elastica	0,24	Freno e frizione
A6500960	Clip ritegno perno leva PR16 e PR19	0,31	Freno e frizione
XR01114	Kit puntalino PR16	61,51	Solo pompe CNC Ø16

PINZE ANTERIORI - FRONT CALIPERS

Pinze radiali (senza pastiglie) per dischi fascia frenante H. 30 mm Radial calipers (without pads) for brake discs with rotor H. 30 mm

XA3B860	SX CNC P4-32/36 pistoni alluminio	828,83	Interasse 108 mm.
XA3B861	DX CNC P4-32/36 pistoni alluminio	828,83	Interasse 108 mm.
XA3B830	SX CNC P4-32/36 pistoni titanio	1.231,41	Interasse 108 mm.
XA3B831	DX CNC P4-32/36 pistoni titanio	1.231,41	Interasse 108 mm.
XA3J7F0	SX monoblocco CNC P4-34/38 - pistoni titanio	2.813,00	Int. 108 mm. - MOTO2 Nickel coating
XA3J7F1	DX monoblocco CNC P4-34/38 - pistoni titanio	2.813,00	Int. 108 mm. - MOTO2 Nickel coating
XB9L2A0	Kit monoblocco DX-SX CNC P4-32/36 - pistoni titanio	3.498,00	Int. 100 mm. - GP4-RR Ossidate dure
XB9L2A1	Kit monoblocco DX-SX CNC P4-32/36 - pistoni titanio	3.498,00	Int. 108 mm. GP4 - RR ossidate dure

Code	Description	€	Note
XA8D1E0	SX monoblocco CNC P4-34/38	3.035,40	Int. 108 mm. - MOTO2 Nickel coating
XA8D1E1	DX monoblocco CNC P4-34/38	3.035,40	Int. 108 mm. - MOTO2 Nickel coating
XA7G2A0	Kit monoblocco DX-SX CNC P4-32/36	3.339,60	Interasse 100 mm.
XA8Y310	SX monoblocco CNC P4-34/38	2.310,00	Int. 130 mm. - Yamaha YZF R1 '07÷'14
XA8Y311	DX monoblocco CNC P4-34/38	2.310,00	Int. 130 mm. - Yamaha YZF R1 '07÷'14
XB0B1H0	SX monoblocco CNC P4-30/34	2.640,00	Pinza EVO, offset 21mm - Int. 108 mm
XB0B1H1	DX monoblocco CNC P4-30/34	2.640,00	Pinza EVO, offset 21mm - Int. 108 mm
XB2P720	SX monoblocco CNC P4-30/34	2.200,00	Interasse 108 mm - ENDURANCE
XB2P721	DX monoblocco CNC P4-30/34	2.200,00	Interasse 108 mm - ENDURANCE
XB6E510	SX monoblocco CNC P4-32/36	2.500,00	Pinza GP4-PR - Int. 108 mm offset 21mm -Nickel coating
XB6E511	DX monoblocco CNC P4-32/36	2.500,00	Pinza GP4-PR - Int. 108 mm offset 21mm -Nickel coating
XA888A0	Kit monoblocco DX-SX pistoni titanio CNC P2-34	3.036,00	Interasse 60 mm. - Moto3
XA88820	SX monoblocco pistoni alluminio CNC P2-34	1.222,00	Interasse 60 mm. - Moto3
XA88821	DX monoblocco pistoni alluminio CNC P2-34	1.222,00	Interasse 60 mm. - Moto3

Pinze radiali (con pastiglie) per dischi fascia frenante H. 34 mm Radial calipers (with pads) for brake discs with rotor H. 34 mm

220D60010	KIT monoblocco CNC GP4-MS SX+DX P4 30	2.500,00	Interasse 100 mm.
220988530	KIT monoblocco forgiata M4 SX+DX P4 34	590,00	Interasse 100 mm.
220988550	KIT monoblocco forgiata M4 SX+DX P4 34	590,00	Interasse 100 mm. - ANODIZ. NERA
220A39710	KIT monoblocco forgiata M4 SX+DX P4 34	590,00	Interasse 108 mm.
220A39750	KIT monoblocco forgiata M4 SX+DX P4 34	590,00	Interasse 108 mm. - ANODIZ. NERA
220A88510	KIT monoblocco forgiata M50 SX+DX P4 30	690,00	Interasse 100 mm.
220D02010	KIT monoblocco forgiata STYLEMA	750,00	Interasse 100 mm.
220A16810	KIT SX+DX CNC P4 30/34	1.250,80	Interasse 100 mm.
220A01610	KIT SX+DX CNC P4 30/34	1.250,80	Interasse 108 mm.
220B01010	KIT SX+DX CNC P4 32	1.362,10	Interasse 108 mm. - NICHELATA GP4-RX
220B01020	KIT SX+DX CNC P4 32	1.456,44	Interasse 100 mm. - NICHELATA GP4-RX
220B01130	KIT SX+DX CNC P4 32	1.456,44	Interasse 130 mm. - NICHELATA GP4-RX
220C78310	KIT monoblocco forgiata GP4-RS SX+DX P4 30	690,00	Interasse 108 mm.
XA69510	SX CNC P4-30/34 (senza pastiglie)	544,65	Interasse 108 mm. - Super motard
XA69511	DX CNC P4-30/34 (senza pastiglie)	544,65	Interasse 108 mm.
XA78910	SX CNC P4-30/34 (senza pastiglie)	583,44	Interasse 100 mm. - Super motard
XA78911	DX CNC P4-30/34 (senza pastiglie)	583,44	Interasse 100 mm.

Pinze assiali (con pastiglie) per dischi fascia frenante 34 mm Axial calipers (with pads) for brake discs with rotor 34 mm

20475652	SX P4 30/34 CNC (con pastiglie)	424,00	Interasse fori 40mm
20475662	DX P4 30/34 CNC (con pastiglie)	424,00	Interasse fori 40mm

PASTIGLIE ANTERIORI - FRONT PADS

Mescola Z01

107684820	Set per pinze monoblocco 101740/41 e 973760/61	105,60	Sp. 10,1 mm - Z01 (ex 07684820)
107684830	Set per pinze 104813/14, XA3B830/31, XA3B860/61	105,60	Sp. 8,35 mm - Z01 (ex 07684830)

Mescola Z10

M478Z10	Set per pinza Brembo P4 34 triple bridge, BMW S 1000 RR '09→'18	170,00*	(107A48657) *Att.: prezzo netto per negozio
M497Z10	Set per pinze M4, M430, M50, GP4-RX, OE Suzuki Honda / K. ZX10 '16	99,00*	(107A48659) *Att.: prezzo netto per negozio
M518Z10	Set per Suzuki GSX R 600/750 '04-'10 / GSX R 1000 '04-'11 / K.ZX10 '08	99,00*	(107A48661) *Att.: prezzo netto per negozio
M538Z10	Set per Yamaha R6 '99→ / R1 '98→ '06 / R1 SP '06 / R1 '15→	99,00*	(107A48663) *Att.: prezzo netto per negozio

Mescola Z03 Endurance

107A48622	Set per pinze monoblocco X973780/81	193,60	Z03 - Spessore 10,1 mm
------------------	-------------------------------------	--------	------------------------



Code	Description	€	Note
M079Z03	Set per KTM 390RC '13→	205,22	(107A48626) - BYBRE calipers
M108Z03	Set per Honda CBR1000RR→	201,40	Z03 (107A48630) - No versione SP
M118Z03	SET BMW S1000RR '19	185,50	(107A48631)
M478Z03	Set per pinza Brembo P4 34 triple bridge, BMW S 1000 RR '09→	228,69	Z03 (107A48667)
M488Z03	Set per Honda CBR RR 600 '05→ CBR 1000 '04→	130,68	Z03 (107A48668)
M497Z03	Set per pinze M4, M430,M50,GP4-RX,OE Suzuki/Honda	160,00	Z03 (107A48669)
M518Z03	Set per Suzuki GSX R 600/750 '04-'10/GSX R 1000 '04-'11, Set per Kawasaki ZX 10 R '08→	190,00	Z03 (107A48671)
M528Z03	Set per Yamaha R1 '07→	236,86	Z03 (107A48672)
M538Z03	Set per pinza Brembo P4 30/34 (interasse 40 mm) e per Yamaha R6 '99→ / R1 '98→ '06 / R1 SP '06	170,00	Z03 (107A48673)
M548Z03	Set per pinza Brembo P4 30/34 (due perni)	149,72	Z03 (107A48674)
M5510Z03	Set per pinze Tokico - Triumph 675	148,65	Z03 (107A48675)
07B36640	Pastiglia singola per pinza monoblocco Brembo P4 30/34	100,00	Specifica per pinza XB2P710/11

Mescola Z04

M028Z04	Set per pinze 104813/14, XA3B830/31, XA3B860/61	138,60	Sp. 8 mm (107A48603)
M029Z04	Set per pinze monoblocco 101740/41, 973760/61 e GP4-RR	118,80	Sp. 9,4 mm (107A48602)
M049Z04	Set per pinze monoblocco X99C460/61 + XA88810/11/20/21	301,95	Sp. 9 mm (107A48604)
M068Z04	Set per Yamaha R3 '15→	140,00	(107A48606)
M079Z04	Set per KTM 390RC '13→	140,00	(107A48607) - BYBRE calipers
M088Z04	Set per Kawasaki Ninja 300 '13→ / Ninja 400 '18→	140,00	(107A48608)
M099Z04	Set per Honda CBR500 '13→ / CBR300 '15→	140,00	(107A48609)
M108Z04	Set per Honda CBR1000RR→	181,72	(107A48610) - No versione SP
M118Z04	SET BMW S1000RR '19	156,89	(107A48611)
M478Z04	Set per pinza Brembo P4 34 triple bridge, BMW S 1000 RR '09→'18	220,37	(107A48647)
M488Z04	Set per Honda CBR RR 600 '05→ CBR 1000 '04→	125,93	(107A48648)
M497Z04	Set per pinze M4, M50, GP4-RX, OE Suzuki / Honda / K. ZX10 '16 / Stylema	132,00	(107A48639)
M508Z04	Set per Kawasaki ZX 6 R '07→	233,49	(107A48650)
M518Z04	Set per Suzuki GSX R 600/750 '04-'10 / GSX R 1000 '04-'11, Set per Kawasaki ZX 10 R '08→ '15	118,06	(107A48651)
M528Z04	Set per Yamaha R1 '07→ '14	228,24	(107A48652)
M538Z04	Set per pinza Brembo P4 30/34 (interasse 40 mm) e per Yamaha R6 '99→/R1 '98→ '06/R1 SP '06/R1→ '15	118,06	(107A48653)
M568Z04	Set per pinza Brembo M4 32 monoblocco (un perno)	169,60	(107A48656)
M5510Z04	Set per pinze Tokico - Triumph 675	143,24	(107A48655)
07B36630	Pastiglia singola per pinza monoblocco EVO P30/34 XB0B180/81	125,00	
07B36690	Pastiglia singola SX per pinza monoblocco EVO P30/34 XB0B180/81	150,00	Per radiatori - Flag to flag
07B36691	Pastiglia singola DX per pinza monoblocco EVO P30/34 XB0B180/81	150,00	Per radiatori - Flag to flag
107670823	Set per pinza Brembo P4 30/34 (due perni)	144,29	
07835424	Pastiglia per pinze XA8Y310/11, XA3J7F0/F1, XA8D1E0/E1, GP4-PR, XB9L2A1	144,29	Pinza a 2 pastiglie

PINZE POSTERIORI - REAR CALIPERS

120A44110	P2-34 CNC Super Sport (con pastiglie)	444,14	Ducati / Aprilia
120A44111	P2-34 CNC Super Sport (con pastiglie) con staffa	589,00	Honda
120A44112	P2-34 CNC Super Sport (con pastiglie) con staffa	589,00	Suzuki
120A44113	P2-34 CNC Super Sport (con pastiglie) con staffa	589,00	Kawasaki
120A44114	P2-34 CNC Super Sport (con pastiglie) con staffa	589,00	Yamaha
120A44116	P2-34 CNC Super Sport (con pastiglie) con staffa	589,00	Suzuki
120A44130	P2-34 CNC Super Sport (con pastiglie)	465,34	Ducati / Aprilia - ANODIZZATA NERA
120A44131	P2-34 CNC Super Sport (con pastiglie) con staffa	609,00	Honda - ANODIZZATA NERA

Code	Description	€	Note
120A44132	P2-34 CNC Super Sport (con pastiglie) con staffa	609,00	Suzuki - ANODIZZATA NERA
120A44133	P2-34 CNC Super Sport (con pastiglie) con staffa	609,00	Kawasaki - ANODIZZATA NERA
120A44134	P2-34 CNC Super Sport (con pastiglie) con staffa	609,00	Yamaha - ANODIZZATA NERA
120A44136	P2-34 CNC Super Sport (con pastiglie) con staffa	609,00	Suzuki - ANODIZZATA NERA
120A44140	P2-34 CNC Super Sport (con pastiglie)	497,14	Ducati / Aprilia - NICHELATA
120A44141	P2-34 CNC Super Sport (con pastiglie) con staffa	639,00	Honda - NICHELATA
120A44142	P2-34 CNC Super Sport (con pastiglie) con staffa	639,00	Suzuki - NICHELATA
120A44143	P2-34 CNC Super Sport (con pastiglie) con staffa	639,00	Kawasaki - NICHELATA
120A44144	P2-34 CNC Super Sport (con pastiglie) con staffa	639,00	Yamaha - NICHELATA
120A44146	P2-34 CNC Super Sport (con pastiglie) con staffa	639,00	Suzuki - NICHELATA
120B27810	P2-34 Sport fusa (con pastiglie)	150,00	Ducati / Aprilia
120B27811	P2-34 Sport fusa (con pastiglie) con staffa	299,99	Honda
120B27812	P2-34 Sport fusa (con pastiglie) con staffa	299,99	Suzuki
120B27813	P2-34 Sport fusa (con pastiglie) con staffa	299,99	Kawasaki
120B27814	P2-34 Sport fusa (con pastiglie) con staffa	299,99	Yamaha
120B27816	P2-34 Sport fusa (con pastiglie) con staffa	299,99	Suzuki
206001	P2-24 (senza pastiglie)	805,16	
206101	P2-24 (senza pastiglie)	947,23	
206121	P2-24 (senza pastiglie)	994,60	Per disco sp. 8 mm.
988870	P2-34 (senza pastiglie)	1.160,37	
XA1J040	P2-30 (senza pastiglie)	1.278,77	
XA0J920	P4 30/34 (senza pastiglie)	1.109,00	Solo in abbinamento con pompa "Pollice"
XA80810	P2 24 - Pinza radiale (senza pastiglie)	1.870,00	

PASTIGLIE POSTERIORI PER PINZE 120Axx e 120Bxx REAR BRAKE PADS FOR CALIPER 120Axx and 120Bxx

07BB20CC	Set pastiglie Carbon Ceramiche		Vedi listino pastiglie standard
07BB2065	Set pastiglie Sinterizzate		Vedi listino pastiglie standard

PASTIGLIE POSTERIORI - REAR BRAKE PADS

(ATTENZIONE: prezzi riferiti alla singola pastiglia - price for 1 pad)

Mescola carbo ceramica

07934010	per pinze XA1J040, 988870, 206101 e 206121	30,80	Sp. 8 mm - H. fascia 30 mm
07934020	per pinze XA1J040, 988870, 206101 e 206121	30,80	Sp. 8 mm - H. fascia 24 mm
07934090	per pinza 206001, XA80810	30,80	Sp. 7,6 mm - H. fascia 24 mm

Mescola Sinterizzata

07934040	per pinze XA1J040, 988870, 206101 e 206121	79,20	Sp. 8 mm - H. fascia 30 mm
07934070	per pinze XA1J040, 988870, 206101 e 206121	81,40	Sp. 7,5 mm - H. fascia 24 mm
07934080	per pinza 206001, XA80810	72,60	Sp. 7,6 mm - H. fascia 24 mm

RICAMBI PINZE - CALIPER SPARE PARTS

101708	Perno in titanio per pinze 101740/41, 973760/61 e 973780/81	37,88	
101739	Vite spurgo per pinze 101740/41, 206001, 206101, 206121, 988870 e XA1J040	5,92	
05281213	Vite spurgo per pinze X99C460/61, 973760/61, 973780/81, XA3B830/31, XA3B860/61 e 104813/14	0,37	
05281228	Vite spurgo per pinze 220A01610, 220A16810 e XA69510	0,37	
05454217	Coppiglia per perno X99C403	6,18	
05454221	Coppiglia per perno 101708 e 20696410	1,23	
05454232	Coppiglia per perno 20394231	1,23	
20394231	Perno per pinze XA7G210/11 e XA93310/11	11,84	
20696410	Perno in titanio per pinze 104813/14 e XA3B830/31	35,53	
20696450	Perno per pinze XA3B860/61	11,84	
22508940	Kit perno + coppiglia pinza posteriore CNC P2 34 Supersport	15,47	
120225579	Molla pastiglie per pinze M50/M4/GP4-RX/GP4-RS	10,05	
120A44170	Perno per pinze posteriori 120A441...	7,40	
X206007	Molla a forchetta per pinze 206001, 206101 e 206121	13,33	
X988815	Molla a forchetta per pinza 988870	41,43	
X988817	Lamierino per pinza 988870	17,00	



Code	Description	€	Note
X988818	Molla apertura pastiglie per pinza 988870	52,10	
X988819	Molla apertura pastiglie per pinza 206001/206101/206121	29,61	
X99C403	Perno in titanio per pinze X99C460/61	61,58	
X99C416	Molla pastiglie per pinze X99C460/61	40,26	
XA1J009	Molla pastiglie per pinza XA1J040	132,62	
XA1J046	Perno in titanio per pinza XA1J040	44,99	
XA1K486	Perno pastiglie per pinza XA1K480	48,05	
XA1K445	Molla pastiglie per pinza XA1K480	29,74	
XA3J718	Kit molle pastiglie pinze monoblocco P4 34/38	68,24	
XA5P405	Perno pastiglie per pinza XA88820/21	28,60	
XA47022	Vite spurgo per pinza posteriore XA80810	10,50	
XA93302	Perno pastiglie per XA7G240/41, XA7G210/11, XA933XX	11,84	
XB0B104	Molla pastiglie per pinze XB0B180/81 E H0/H1	33,00	
XB0B107	Kit radiatori per pinze ENDURANCE - XB2P720/21	332,45	

DISTANZIALI PER KIT PINZE 220A01610 SPACERS FOR 220A01610

HONDA

105998709	Kit 4 viti - dist.non necessari	8,00
220A02411	Kit 4 viti + 4 distanziali (per disco Ø 320 mm)	32,07

KAWASAKI

220A02411	Kit 4 viti + 4 distanziali	32,07
220A02431	Kit 4 viti + 4 distanziali (per disco Ø 320 mm)	32,07
220A06127	Kit 4 viti + 4 distanziali	32,07
220A06137	Kit 4 viti + 4 distanziali (per disco Ø 320 mm)	32,07

SUZUKI

220A02411	Kit 4 viti + 4 distanziali	32,07
220A02431	Kit 4 viti + 4 distanziali (per disco Ø 320 mm)	32,07
220A06127	Kit 4 viti + 4 distanziali	32,07
220A06137	Kit 4 viti + 4 distanziali	32,07

YAMAHA

220A06125	Kit 4 viti + 4 distanziali	32,07
220A06135	Kit 4 viti + 4 distanziali (per disco Ø 320 mm)	32,07

DISTANZIALI PER KIT PINZE M4 cod. 220A39710 - GP4-RX COD. 220B01010 - GP4-RS cod.220C78310 SPACERS FOR CALIPERS M4 cod. 220A39710 - GP4-RX COD. 220B01010 - GP4-RS cod.220C78310

HONDA

105998709	Kit 4 viti - dist.non necessari	8,00
-----------	---------------------------------	------

KAWASAKI

105998709	Kit 4 viti - dist.non necessari	8,00
220A02421	Kit 4 viti + 4 distanziali (per disco Ø 320 mm)	32,07
220A06117	Kit 4 viti + 4 distanziali	32,07
220A06177	Kit 4 viti + 4 distanziali (per disco Ø 320 mm)	32,07

SUZUKI

105998709	Kit 4 viti - dist.non necessari	8,00
220A02421	Kit 4 viti + 4 distanziali	32,07
220A02431	Kit 4 viti + 4 distanziali (per disco Ø 320 mm)	32,07
220A06117	Kit 4 viti + 4 distanziali	32,07
220A06177	Kit 4 viti + 4 distanziali (per disco Ø 320 mm)	32,07

YAMAHA

220A06115	Kit 4 viti + 4 distanziali	32,07
220A06175	Kit 4 viti + 4 distanziali (per disco Ø 320 mm)	32,07

Code	Description	€	Note
ACCESSORI - ACCESSORIES			
02516811	Kit Thermotape (blocco da 10 adesivi da 88 °C a 127 °C)	33,15	
02516812	Kit Thermotape (blocco da 10 adesivi da 132 °C a 171 °C)	33,15	
TDF	Tester per fluido freni	88,00	
FLUIDO FRENI - BRAKE FLUID			
04816450	Confezione da 250 cc. Brembo Racing DOT 4	7,99	
04816411	Confezione da 500 cc. Brembo Racing LCF 600	21,50	
COSTO SERVIZIO REVISIONI - OVERHAULING			
REVPRA	Revisione pompe radiali freno forgiate	94,00	* Solo revisione se pompa completa
REVPRB	Revisione pompe radiali freno forgiate	110,50	* Revisione + reintegro pezzi mancanti
REVXRA	Revisione pompe radiali freno/frizione serie XR	110,50	* Solo revisione se pompa completa
REVXRB	Revisione pompe radiali freno/frizione serie XR	128,00	* Revisione + reintegro pezzi mancanti
REVRCSA	Revisione pompe radiali freno/frizione RCS	85,00	* Solo revisione se pompa completa
REVRCSB	Revisione pompe radiali freno/frizione RCS	162,00	* Revisione + reintegro pezzi mancanti
REVPRCCB	Revisione pompe radiali freno/frizione RCS Corsa Corta	220,00	* Revisione / Sostituzione leva
REVM4	Revisione pinza M4 interasse 108 mm	85,00	* Cad.
REVGP4RX	Revisione pinza CNC P4 30/34 + GP4-RX	102,00	* Cad.
REVBC	Revisione pinza CNC (tutte le referenze)	169,00	* Cad.
REVBCR	Revisione pinza posteriore CNC (tutte le referenze)	128,00	* Cad.

* ATTENZIONE: prezzo netto per negozio



BREMBO PERFORMANCE LINE

Code	Description	€	Note
------	-------------	---	------

DISCO CAFE' RACER "THE GROVE" FASCIA FRENANTE 34 mm th 5,5 mm CAFE' RACER "THE GROVE" BRAKE DISK WITH ROTOR HEIGHT 34 mm th 5,5

APRILIA

208B47010	Ø 320 mm	294,00 cad.	
-----------	----------	-------------	--

BENELLI

208B47010	Ø 320 mm	294,00 cad.	
-----------	----------	-------------	--

BIMOTA

208B47010	Ø 320 mm	294,00 cad.	
-----------	----------	-------------	--

DUCATI

208B47010	Ø 320 mm	294,00 cad.	
-----------	----------	-------------	--

208B47011	Ø 320 mm	294,00 cad.	
-----------	----------	-------------	--

208B47036	Ø 320 mm	294,00 cad.	
-----------	----------	-------------	--

108C56058	Ø 330 mm	294,00 cad.	
-----------	----------	-------------	--

KAWASAKI

208B47014	Ø 300 mm	294,00 cad.	
-----------	----------	-------------	--

208B47034	Ø 310 mm	294,00 cad.	
-----------	----------	-------------	--

208B47022	Ø 320 mm	294,00 cad.	
-----------	----------	-------------	--

208C56022	Ø 330 mm solo per ZX10R 2016 ->	294,00 cad.	
-----------	---------------------------------	-------------	--

KTM

208B47010	Ø 320 mm	294,00 cad.	
-----------	----------	-------------	--

SUZUKI

208B47035	Ø 310 mm	294,00 cad.	
-----------	----------	-------------	--

TRIUMPH

208B47037	Ø 320 mm	294,00 cad.	
-----------	----------	-------------	--

YAMAHA

108B47018	Ø 300 mm	294,00 cad.	
-----------	----------	-------------	--

208B47019	Ø 300 mm	294,00 cad.	
-----------	----------	-------------	--

208B47021	Ø 320 mm	294,00 cad.	
-----------	----------	-------------	--

208B47048	Ø 320 mm	294,00 cad.	
-----------	----------	-------------	--

HARLEY DAVIDSON

108B33510	Ø 292 mm per XR 1200 '08 > e XR1200X '10>	225,50 cad.	
-----------	-------------------------------------------	-------------	--

208B33510	Ø 292 mm per XR 1200 '08 > e XR1200X '10>	445,00 cad.	Kit doppio disco
-----------	-------------------------------------------	-------------	------------------

108B33511	Ø 292 mm per moto custom con disco originale da 292mm	225,50 cad.	
-----------	-------------------------------------------------------	-------------	--

POMPE FRENO - BRAKE M/C

110A89710	Pompa radiale PR 19x18-20 - 19RCS	315,00	(manubri 1" - Harley Davidson)
-----------	-----------------------------------	--------	--------------------------------

110A89730	Pompa radiale PR 15x18-20 - 15RCS	315,00	(manubri 1" - Harley Davidson)
-----------	-----------------------------------	--------	--------------------------------

POMPE FRIZIONE - CLUTCH M/C

110A89770	Pompa radiale PR 19x18-20 - 19RCS	315,00	(manubri 1" - Harley Davidson)
-----------	-----------------------------------	--------	--------------------------------

PINZE ANTERIORI CAFE RACER ".484" - ".484" CAFE RACER FRONT CALIPER

220B47310	KIT SX+DX CNC P4 32 (con pastiglie)	1.427,93	Interasse 100 mm. - Ossidata nera .484
-----------	-------------------------------------	----------	----------------------------------------

220B47320	KIT SX+DX CNC P4 32 (con pastiglie)	1.427,93	Interasse 108 mm. - Ossidata nera .484
-----------	-------------------------------------	----------	----------------------------------------

120B81469	pinza assiale SX CNC P4 32 (con pastiglie)	633,88	Ossidata nera logo nero
-----------	--------------------------------------------	--------	-------------------------

120B81479	pinza assiale DX CNC P4 32 (con pastiglie)	633,88	Ossidata nera logo nero
-----------	--------------------------------------------	--------	-------------------------

120B81471	pinza assiale SX CNC P4 32 (con pastiglie)	686,88	Ossidata nera logo puro
-----------	--------------------------------------------	--------	-------------------------

120B81481	pinza assiale DX CNC P4 32 (con pastiglie)	686,88	Ossidata nera logo puro
-----------	--------------------------------------------	--------	-------------------------

Code	Description	€	Note
KIT TRASFORMAZIONE - UPGRADE KIT			
YAMAHA T-MAX			
220B76510	KIT pinze P4 30/34 CNC (con pastiglie) + adattatori CNC	899,00	per dischi originali
220B76610	KIT pinze P4 30/34 fusa (con pastiglie) + adattatori CNC	399,00	per dischi originali
KAWASAKI NINJA 250/300			
120B76620	KIT pinza SX int. 40 mm forgiata P4 30/34 (con pastiglie e staffa)	399,00	per dischi Ø 300 mm
120B76520	KIT pinza SX int. 40 mm CNC P4 30/34 (con pastiglie e staffa)	600,00	per dischi Ø 300 mm
108973749	Ø 300 mm - NINJA 250	249,00	
108973757	Ø 300 mm - NINJA 300	249,00	
POMPE FRENO - BRAKE M/C			
110A26345	Pompa radiale PR 14x18-20 - 14RCS	263,00	Interasse leva variabile - Lato DX
110A26365	Pompa radiale PR 14x18-20 - 14RCS	263,00	Interasse leva variabile - Lato SX



SUPER MOTARD

Code	Description	€	Note
DISCO FASCIA FRENANTE H. 34 mm Th 5,5 mm - DISC WITH ROTOR H. 34 mm Th 5,5 mm			
APRILIA			
108A64215	SXV 4.5 e 5.5	288,00	Ø 320 mm
HONDA			
108A64211	CRF 450 Super Motard	288,00	Ø 320 mm
KAWASAKI			
108A64217	KX 450 F Super Motard	288,00	Ø 320 mm
KTM			
108A64212	SX 450 - SXC 450 Super Motard	288,00	Ø 320 mm OFF SET 0 mm
108A64213	SX 450 - SXC 450 Super Motard	288,00	Ø 320 mm OFF SET 8,75 mm
SUZUKI			
108A64214	RMZ 450	288,00	Ø 320 mm
YAMAHA			
108A64218	YZF 450	288,00	Ø 320 mm
POMPE FRENO - MASTER CYLNDERS			
110A26320	Pompa radiale PR 15x18-20 - 15RCS - leva corta	279,00	Interasse leva variabile - per monodisco
10476082	Pompa radiale PR 16x18 (Forgiata - con leva corta)	222,44	Per Monodisco
XR011B0	Pompa radiale PR 16x16 (Ricavata CNC - con leva corta)	544,54	Per Monodisco
PINZE - CALIPERS			
Pinze radiali per dischi fascia frenante H. 30 mm th. 6 mm			
Radial calipers for disc with rotor H. 30 mm th 6 mm			
XA3B860	SX CNC P4-32/36 pistoncini alluminio (senza past)	828,83	Interasse 108 mm.
XA3B830	SX CNC P4-32/36 pistoncini titanio (senza past)	1.231,41	Interasse 108 mm.
Pinze radiali per dischi fascia frenante H. 34 mm th. 5,5 mm			
Radial calipers for disc with rotor H. 34 mm th 5,5 mm			
XA69510	SX CNC P4-30/34 (senza pastiglie)	544,65	Interasse 108 mm. - Super motard
XA78910	SX CNC P4-30/34 (senza pastastiglie)	583,44	Interasse 100 mm. - Super motard

MX ed ENDURO

Code	Description	€	Note
KIT OVERSIZE MX/ENDURO MX/ENDURO OVERSIZED KIT			
122B06921	Honda CRF 250 - 450	209,00	Disco Ø 267 th. 3,0 mm + staffa + pastiglie per pinza originale
122B06922	Ktm 125 - 250 - 450	209,00	Disco Ø 267 th. 3,0 mm + staffa + pastiglie per pinza originale
122B06924	Suzuki RMZ 250 - 450	209,00	Disco Ø 267 th. 3,0 mm + staffa + pastiglie per pinza originale
122B06925	Aprilia RXV - SXV 450 -550	209,00	Disco Ø 267 th. 3,0 mm + staffa + pastiglie per pinza originale
122B06926	Husqvarna 125 - 250 - 450 - 510	209,00	Disco Ø 267 th. 3,0 mm + staffa + pastiglie per pinza originale
122B06927	Kawasaki KX 250 - KXF 450 - KLX R 450	209,00	Disco Ø 267 th. 3,0 mm + staffa + pastiglie per pinza originale
122B06928	Yamaha YZF / WRF 250 - 450 '03→'12	209,00	Disco Ø 267 th. 3,0 mm + staffa + pastiglie per pinza originale
122B069A8	Yamaha YZF 250 - 450 '08→'13	209,00	Disco Ø 267 th. 3,0 mm + staffa + pastiglie per pinza originale

DISCHI OVERSIZE MX/ENDURO MX/ENDURO OVERSIZED KIT

08A64251	Honda CRF 250 - 450	152,00	Disco Ø 267 th. 3,0 mm
08A64252	Ktm 125 - 250 - 450	152,00	Disco Ø 267 th. 3,0 mm
08A64254	Suzuki RMZ 250 - 450	152,00	Disco Ø 267 th. 3,0 mm
08A64255	Aprilia RXV - SXV 450 -550	152,00	Disco Ø 267 th. 3,0 mm
08A64256	Husqvarna 125 - 250 - 450 - 510	152,00	Disco Ø 267 th. 3,0 mm
08A64257	Kawasaki KX 250 - KXF 450 - KLX R 450	152,00	Disco Ø 267 th. 3,0 mm
08A64258	Yamaha YZF / WRF 250 - 450	152,00	Disco Ø 267 th. 3,0 mm

POMPE FRENO ANTERIORI FRONT MASTER CYLINDERS

110D08715	Pompa PS 9x19	178,00	MX
XA2B380	Pompa PS 10x19	449,94	Enduro
XA2B3A0	Pompa PS 10x19 (Ricavata CNC)	572,00	

POMPE FRENO POSTERIORI REAR MASTER CYLINDERS

XA0J010	Pompa PS 13 CNC con serbatoio incorporato	1.040,92	Serbatoio integrato
XA2C610	Pompa PS 13 CNC con serbatoio incorporato	1.350,00	Serbatoio integrato - con puntale
XA2C620	Pompa PS 13 CNC con serbatoio incorporato	1.350,00	Serbatoio integrato - senza puntale

POMPE FRIZIONI CLUTCH MASTER CYLINDERS

XR01610	Pompa PS 10x17,7	180,00	
---------	------------------	--------	--

LEVE - LEVERS

10459478	Leva per pompa XA2B3A0	34,59	
110270606	Leva per pompe frizioni XR01610	46,04	

PINZE ANTERIORI FRONT CALIPERS

Pinze Radiali

XA1K480	SX CNC P4-26/28 (senza pastigile)	1.728,69	MX - Interasse 40 mm.
---------	-----------------------------------	----------	-----------------------

Pinze Assiali

XQ21361	SX PF2 x 28 - con staffa montaggio	757,79	KTM SXS
122A99021	SX PF2 x 24 - con staffa montaggio	799,00	KTM SXS



Code	Description	€	Note
XB7B854	Kit M2-X GP, pinza PF2 x 24 CNC, con staffa CNC e pastiglie sinterizzate *	253,00	Yamaha con disco 270 mm
XB7B855	Kit M2-X GP, pinza PF2 x 24 CNC, con staffa CNC e pastiglie sinterizzate *	253,00	Suzuki con disco 270 mm
XB7B856	Kit M2-X GP, pinza PF2 x 24 CNC, con staffa CNC e pastiglie sinterizzate *	253,00	Honda con disco 270 mm
XB7B857	Kit M2-X GP, pinza PF2 x 24 CNC, con staffa CNC e pastiglie sinterizzate *	253,00	Kawasaki con disco 270 mm

* Da montare con pompa PS 10/19mm

PINZE POSTERIORI REAR CALIPERS

XQ21390	DX PF26 - con staffa montaggio	686,75	KTM SXS
----------------	--------------------------------	--------	---------

RICAMBI PINZE CALIPER SPARE PARTS

M057Z04	Kit (1sx + 1dx) per pinza XA1K480	123,75	Sp. 7,6 mm - Z04 (107A48605)
M467Z04	Kit (1sx + 1dx) per pinza XQ21361	133,80	Sp. 7,5 mm - Z04 (107A48646)
07526971	Pastiglia sinistra per pinza XQ21361	17,60	Sp. 7,5 mm - TT2701
07526981	Pastiglia destra per pinza XQ21361	17,60	Sp. 7,5 mm - TT2701

PASTIGLIE ANTERIORI FRONT PADS

M057Z04	Kit (1sx + 1dx) per pinza XA1K480	123,75	Sp. 7,6 mm - Z04 (107A48605)
M467Z04	Kit (1sx + 1dx) per pinza XQ21361	126,23	Sp. 7,5 mm - Z04 (107A48646)

PASTIGLIE POSTERIORI REAR PADS

07849312	Pastiglia sinistra per pinza XQ21390	14,74	Sp. 7,5 mm
07849327	Pastiglia destra per pinza XQ21390	23,10	Sp. 7,5 mm - (piastrina inclusa)

DISCHI SERIE ORO

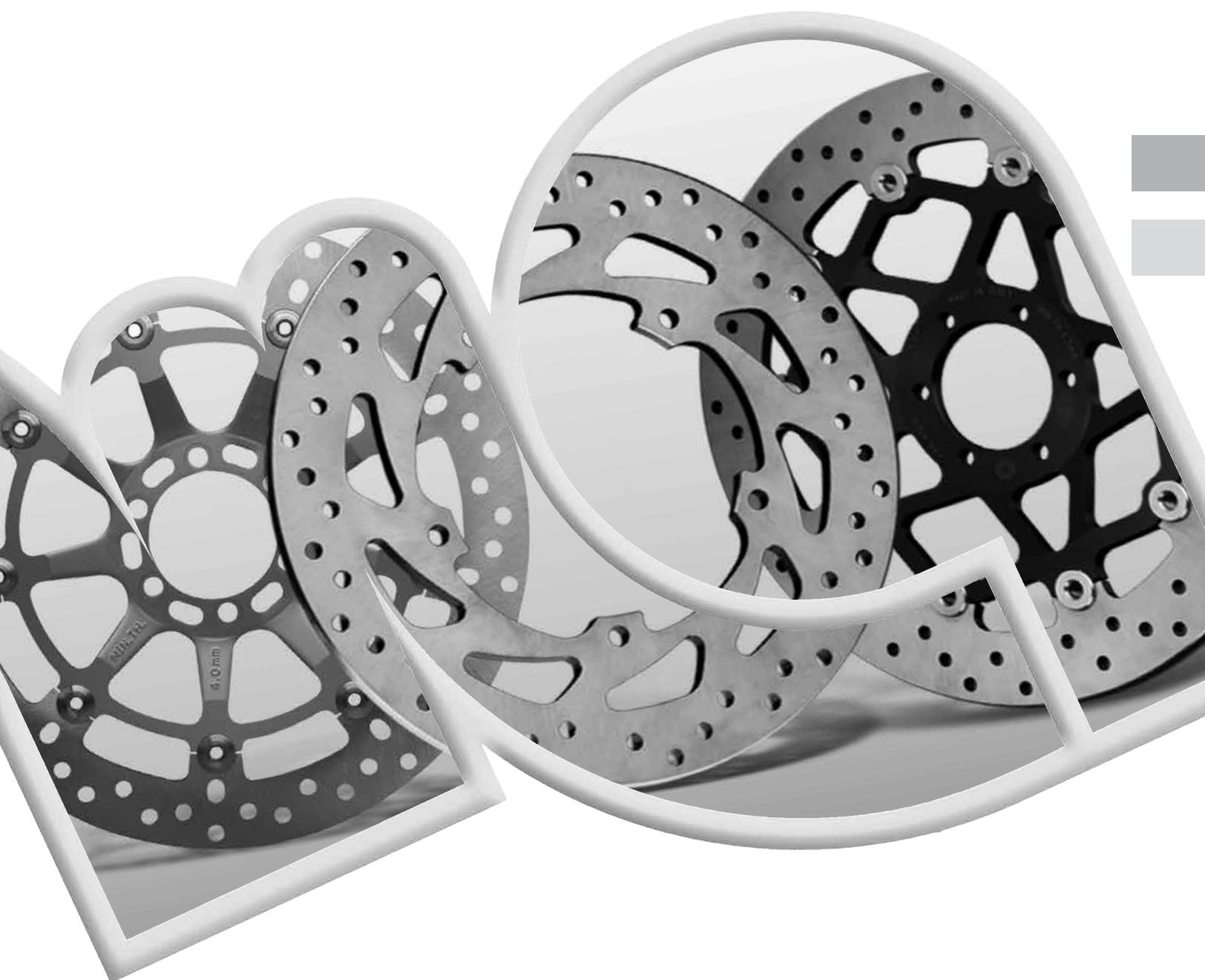



DISCHI / DISCS

Code	€	Code	€	Code	€
DISCHI SERIE ORO FLOTTANTI SERIE ORO FLOATING BRAKE DISCS					
78B40810	142,00	78B40842	207,00	78B40887	207,00
78B40811	142,00	78B40843	218,00	78B40888	239,00
78B40812	142,00	78B40844	164,00	78B40889	249,00
78B40813	142,00	78B40845	218,00	78B40890	248,00
78B40814	144,00	78B40846	198,00	78B40891	207,00
78B40815	206,00	78B40847	228,00	78B40892	228,00
78B40816	213,00	78B40848	154,00	78B40893	239,00
78B40817	155,00	78B40849	207,00	78B40894	207,00
78B40818	154,00	78B40850	207,00	78B40895	249,00
78B40819	164,00	78B40859	228,00	78B40896	207,00
78B40820	228,00	78B40860	209,00	78B40897	216,00
78B40821	207,00	78B40861	209,00	78B40898	259,00
78B40822	203,00	78B40862	228,00	78B40899	249,00
78B40823	228,00	78B40863	207,00	78B408A0	259,00
78B40824	228,00	78B40864	209,00	78B408A1	249,00
78B40825	228,00	78B40865	209,00	78B408A2	249,00
78B40826	238,00	78B40866	209,00	78B408A3	258,00
78B40827	238,00	78B40867	228,00	78B408A4	249,00
78B40828	197,00	78B40868	218,00	78B408A5	218,00
78B40829	228,00	78B40869	228,00	78B408A6	155,00
78B40830	207,00	78B40870	229,00	78B408A7	238,00
78B40831	207,00	78B40871	208,00	78B408A8	207,00
78B40833	165,00	78B40872	208,00	78B408A9	155,00
78B40835	156,00	78B40873	208,00	78B408B0	228,00
78B40836	165,00	78B40874	229,00	78B408B1	228,00
78B40837	207,00	78B40875	208,00	78B408B2	249,00
78B40838	238,00	78B40876	239,00	78B408B3	239,00
78B40839	165,00	78B40877	229,00	78B408B4	258,00
78B40840	207,00	78B40878	209,00	78B408B5	249,00
78B40841	218,00	78B40880	239,00	78B408B7	238,00
		78B40881	229,00	78B408B8	259,00
		78B40884	228,00		
		78B40885	228,00		
		78B40886	239,00		

DISCHI SERIE ORO FISSI SERIE ORO FIXED BRAKE DISCS

Code	€	Code	€	Code	€
68B40711	51,00	68B40736	69,00	68B40760	87,00
68B40713	53,00	68B40737	73,00	68B40761	104,00
68B40714	61,00	68B40738	61,00	68B40762	79,00
68B40715	61,00	68B40739	62,00	68B40765	75,00
68B40716	61,00	68B40740	66,00	68B40767	66,00
68B40717	52,00	68B40741	73,00	68B40768	83,00
68B40718	65,00	68B40742	73,00	68B40769	79,00
68B40719	59,00	68B40743	93,00	68B40770	79,00
68B40720	62,00	68B40744	83,00	68B40771	94,00
68B40721	66,00	68B40746	73,00	68B40772	76,00
68B40722	59,00	68B40747	83,00	68B40774	69,00
68B40723	66,00	68B40748	73,00	68B40775	74,00
68B40724	65,00	68B40749	73,00	68B40776	69,00
68B40725	152,00	68B40750	83,00	68B40777	79,00
68B40726	70,00	68B40751	72,00	68B40778	75,00
68B40727	70,00	68B40752	69,00	68B40779	94,00
68B40728	83,00	68B40753	83,00	68B40780	84,00
68B40729	65,00	68B40754	73,00	68B40781	90,00
68B40730	66,00	68B40755	83,00	68B40782	83,00
68B40731	68,00	68B40756	73,00	68B40783	90,00
68B40732	67,00	68B40757	79,00	68B40784	83,00
68B40734	83,00	68B40758	72,50	68B40785	94,00
68B40735	70,00	68B40759	69,00	68B40786	76,00

DISCHI / DISCS

Code	€	Code	€	Code	€
68B40788	83,00	68B407F5	110,00	68B407N5	90,00
68B40789	83,00	68B407F6	108,00	68B407N6	114,00
68B40790	86,00	68B407F7	94,00	68B407N9	80,00
68B40791	72,00	68B407F8	115,00	68B407P0	70,00
68B40792	104,00	68B407F9	73,00	68B407P1	83,00
68B40793	94,00	68B407G0	94,00	68B407P2	83,00
68B40794	104,00	68B407G1	62,00	68B407P3	86,00
68B40795	73,00	68B407G2	83,00	68B407P4	83,00
68B40796	73,00	68B407G3	83,00	68B407P5	116,00
68B40797	93,00	68B407G4	116,00	68B407P6	111,00
68B40798	73,00	68B407G5	116,00	68B407P7	114,00
68B40799	84,00	68B407G6	83,00	68B407P8	79,00
68B407A1	84,00	68B407G7	115,00	68B407P9	173,00
68B407A2	97,00	68B407G8	83,00	168B407D6	158,00
68B407A3	94,00	68B407G9	94,00	168B407D7	158,00
68B407A4	94,00	68B407H0	94,00	105577612	41,00
68B407A5	83,00	68B407H1	104,00	105577515	41,00
68B407A6	88,00	68B407H2	126,00		
68B407A7	86,00	68B407H3	88,00		
68B407A8	92,00	68B407H5	115,00		
68B407A9	69,00	68B407H6	85,00		
68B407B0	80,00	68B407H7	99,00		
68B407B1	145,00	68B407H8	90,00		
68B407B2	82,00	68B407J1	73,00		
68B407B4	90,00	68B407J2	93,00		
68B407B5	94,00	68B407J3	116,00		
68B407B6	77,00	68B407J4	75,00		
68B407B7	83,00	68B407J5	110,00		
68B407B8	83,00	68B407J6	84,00		
68B407B9	83,00	68B407J7	93,00		
68B407C0	97,00	68B407J8	83,00		
68B407C1	94,00	68B407J9	83,00		
68B407C2	87,00	68B407K1	137,00		
68B407C3	80,00	68B407K2	137,00		
68B407C4	89,00	68B407K3	137,00		
68B407C5	90,00	68B407K4	94,00		
68B407C6	94,00	68B407K5	94,00		
68B407C7	94,00	68B407K6	83,00		
68B407C8	100,00	68B407K7	93,00		
68B407C9	84,00	68B407K8	73,00		
68B407D0	105,00	68B407K9	104,00		
68B407D2	145,00	68B407L0	104,00		
68B407D3	167,00	68B407L1	126,00		
68B407D4	116,00	68B407L2	126,00		
68B407D5	105,00	68B407L3	137,00		
68B407D6	117,00	68B407L4	79,00		
68B407D7	117,00	68B407L5	79,00		
68B407D8	65,00	68B407L6	83,00		
68B407D9	84,00	68B407L7	65,00		
68B407E0	116,00	68B407L8	104,00		
68B407E1	94,00	68B407L9	94,00		
68B407E3	94,00	68B407M0	93,00		
68B407E4	84,00	68B407M1	93,00		
68B407E5	89,00	68B407M2	65,00		
68B407E6	90,00	68B407M3	62,00		
68B407E7	115,00	68B407M4	126,00		
68B407E8	114,00	68B407M5	93,00		
68B407E9	111,00	68B407M7	104,00		
68B407F0	104,00	68B407M8	83,00		
68B407F1	94,00	68B407M9	104,00		
68B407F2	83,00	68B407N0	137,00		
68B407F3	117,00	68B407N1	126,00		
68B407F4	73,00	68B407N3	86,00		

SPRINT FILTER

*SPRINT
FILTER*



sf **SPRINT
FILTER**

FILTRI ARIA - AIR FILTERS

CC	Modello Model	Anno Years	Codice Code	€
APRILIA				
450	RXV	'06→'13	PM05S	70,00
450	SXV SUPERMOTO	'06→'13	PM05S	70,00
450	SXV VAN DEN BOSCH REPLICA	'08	PM05S	70,00
550	RXV	'06→'13	PM05S	70,00
550	SXV SUPERMOTO	'06→'13	PM05S	70,00
550	SXV VAN DEN BOSCH REPLICA	'08	PM05S	70,00
660	RS	'20→	PM176S	90,00
660	RS (filtro P037)	'20→	PM176S-WP	* 180,00
660	RS (filtro PF1-85)	'20→	PM176SF1-85	* 199,00
750	DORSODURO	'08→'12	PM108S	73,00
750	DORSODURO ABS	'13→'16	PM108S	73,00
750	DORSODURO FACTORY	'10→'13	PM108S	73,00
750	DORSODURO FACTORY ABS	'10→'13	PM108S	73,00
750	SHIVER	'07→'16	PM108S	73,00
750	SHIVER ABS	'13→'16	PM108S	73,00
750	SHIVER GT	'09→'10	PM108S	73,00
750	SHIVER GT ABS	'10→'13	PM108S	73,00
850	SRV	'12	PM120S	70,00
850	SRV ABS	'12→'14	PM120S	70,00
900	DORSODURO ABS	'17→'20	PM108S	73,00
900	SHIVER ABS	'17→'20	PM108S	73,00
1000	RST FUTURA (OEM: AP8102610)	'01→'04	CM06S	71,00
1000	RSV (OEM: AP8102610)	'98→'00	CM06S	71,00
1000	RSV (OEM: AP8104211)	'01→'04	CM02S	69,80
1000	RSV DREAM (OEM: AP8104329)	'04→'08	PM05S	70,00
1000	RSV FACTORY (OEM: AP8104329)	'04→'08	PM05S	70,00
1000	RSV R (OEM: AP8102610)	'00	CM06S	71,00
1000	RSV R (OEM: AP8104211)	'01→'03	CM02S	69,80
1000	RSV R (OEM: AP8104329)	'04→'08	PM05S	70,00
1000	RSV SP (OEM: AP8102610)	'99→'00	CM06S	71,00
1000	RSV4 APRC R (OEM: AP8104329)	'11→'12	PM05S	70,00
1000	RSV4 APRC R ABS (OEM: AP8104329)	'13→'14	PM05S	70,00
1000	RSV4 APRC SE (OEM: AP858930)	'11→'12	PM94S	86,00
1000	RSV4 APRC STD (OEM: AP858930)	'11→'12	PM94S	86,00
1000	RSV4 APRC STD (OEM: AP8104329)	'11→'12	PM05S	70,00
1000	RSV4 FACTORY (OEM: AP858930)	'09→'10	PM94S	86,00
1000	RSV4 FACTORY APRC ABS (OEM: AP858930)	'13→'14	PM94S	86,00
1000	RSV4 FACTORY APRC ABS (OEM: AP8104329)	'13→'14	PM05S	70,00
1000	RSV4 R (OEM: AP858930)	'09→'10	PM94S	86,00
1000	RSV4 RF	'15→'19	PM147S	90,00
1000	RSV4 RF (filtro P16)	'15→'19	PM147S16	* 180,00
1000	RSV4 RF (filtro PF1-85)	'15→'19	PM147SF1-85	* 199,00
1000	RSV4 RR	'15→'20	PM147S	90,00
1000	RSV4 RR (filtro P16)	'15→'20	PM147S16	* 180,00
1000	RSV4 RR (filtro PF1-85)	'15→'20	PM147SF1-85	* 199,00
1000	RSV4 RR RACER PACK	'15	PM147S	90,00
1000	RSV4 RR RACER PACK (filtro P16)	'15	PM147S16	* 180,00
1000	RSV4 RR RACER PACK (filtro PF1-85)	'15	PM147SF1-85	* 199,00
1000	RSV4 SBK RACING (OEM: AP858930)	'09→'10	PM94S	86,00
1000	SL FALCO (OEM: AP8102610)	'99→'04	CM06S	71,00
1000	TUONO	'02→'05	CM02S	69,80
1000	TUONO R	'02→'05	CM02S	69,80
1000	TUONO R	'07→'10	PM05S	70,00
1000	TUONO R FACTORY	'06→'10	PM05S	70,00
1000	TUONO V4 R (OEM: AP8104329)	'11→'15	PM05S	70,00
1000	TUONO V4 R APRC (OEM: AP8104329)	'11→'13	PM05S	70,00
1000	TUONO V4 R APRC ABS (OEM: AP8104329)	'13→'15	PM05S	70,00
1100	RSV4 FACTORY	'19→'20	PM147S	90,00
1100	RSV4 FACTORY (filtro P16)	'19→'20	PM147S16	* 180,00
1100	RSV4 FACTORY (filtro PF1-85)	'19→'20	PM147SF1-85	* 199,00

FILTRI ARIA - AIR FILTERS

CC	Modello Model	Anno Years	Codice Code	€
1100	TUONO V4 FACTORY (OEM: AP8104329)	'15→'20	PM05S	70,00
1100	TUONO V4 RR (OEM: AP8104329)	'15→'20	PM05S	70,00

BIMOTA

1000	BB3	'14→'15	PM93S	80,60
1000	BB3 (filtro P16)	'14→'15	PM93S16	* 162,00
1000	BB3 (filtro PF1-85)	'14→'15	PM93SF1-85	* 199,00
1000	TESI H2	'20→	PM153S	90,00
1000	TESI H2 (filtro P037)	'20→	PM153S-WP	* 180,00
1000	TESI H2 (filtro PF1-85)	'20→	PM153SF1-85	* 199,00
1100	DB7	'08→'12	CM13S	78,75
1198	DB8	'14→'17	CM13S	78,75
1198	DB8 SP	'10→'13	CM13S	78,75
1198	DB9 BRIVIDO	'12→'13	CM13S	78,75
1198	DB11	'11→'15	CM13S	78,75

(*) Questi articoli non hanno la solita scontistica ma un prezzo netto per il rivenditore.

BMW

310	G 310 GS	'18→'19	PM189S	65,00
310	G 310 GS (filtro P037)	'18→'19	PM189S-WP	* 130,00
310	G 310 GS (filtro PF1-85)	'18→'19	PM189SF1-85	* 199,00
310	G 310 R	'17→'19	PM189S	65,00
310	G 310 R (filtro P037)	'17→'19	PM189S-WP	* 130,00
310	G 310 R (filtro PF1-85)	'17→'19	PM189SF1-85	* 199,00
600	C 600 SPORT	'11→'15	PM146S	51,80
650	C 650 GT	'11→'20	PM146S	51,80
650	C 650 SPORT	'15→'20	PM146S	51,80
650	F 650 CS SCARVER	'00→'07	PM138S	68,00
650	F 650 GS	'08→'12	PM109S	51,80
650	F 650 GS (filtro PF1-85)	'08→'12	PM109SF1-85	* 199,00
650	F 650 GS (filtro P037)	'08→'12	PM109S-WP	* 104,00
650	F 650 GS 30 YEARS GS	'11	PM109S	51,80
650	F 650 GS 30 YEARS GS (filtro PF1-85)	'11	PM109SF1-85	* 199,00
650	F 650 GS 30 YEARS GS (filtro P037)	'11	PM109S-WP	* 104,00
650	G 650 XCHALLENGE	'07→'09	PM138S	68,00
650	G 650 XCOUNTRY	'06→'09	PM138S	68,00
650	G 650 XMOTO	'07→'09	PM138S	68,00
700	F 700 GS	'11→'18	PM109S	51,80
700	F 700 GS (filtro PF1-85)	'11→'18	PM109SF1-85	* 199,00
700	F 700 GS (filtro P037)	'11→'18	PM109S-WP	* 104,00
700	F 750 GS	'17→'20	PM188S	78,00
700	F 750 GS (filtro P037)	'17→'20	PM188S-WP	* 156,00
700	F 750 GS (filtro PF1-85)	'17→'20	PM188SF1-85	* 199,00
800	F 800 GS	'08→'18	PM109S	51,80
800	F 800 GS (filtro PF1-85)	'08→'18	PM109SF1-85	* 199,00
800	F 800 GS (filtro P037)	'08→'18	PM109S-WP	* 104,00
800	F 800 GS 30 YEARS GS	'11	PM109S	51,80
800	F 800 GS 30 YEARS GS (filtro PF1-85)	'11	PM109SF1-85	* 199,00
800	F 800 GS 30 YEARS GS (filtro P037)	'11	PM109S-WP	* 104,00
800	F 800 GS ADVENTURE	'12→'18	PM109S	51,80
800	F 800 GS ADVENTURE (filtro PF1-85)	'12→'18	PM109SF1-85	* 199,00
800	F 800 GS ADVENTURE (filtro P037)	'12→'18	PM109S-WP	* 104,00
800	F 800 GS TRIPLE BLACK	'12	PM109S	51,80
800	F 800 GS TRIPLE BLACK (filtro PF1-85)	'12	PM109SF1-85	* 199,00
800	F 800 GS TRIPLE BLACK (filtro P037)	'12	PM109S-WP	* 104,00
800	F 800 GS TROPHY	'12	PM109S	51,80
800	F 800 GS TROPHY (filtro PF1-85)	'12	PM109SF1-85	* 199,00
800	F 800 GS TRPPHY (filtro P037)	'12	PM109S-WP	* 104,00
800	F 800 GT	'11→'20	PM109S	51,80
800	F 800 GT (filtro PF1-85)	'11→'20	PM109SF1-85	* 199,00
800	F 800 GT (filtro P037)	'11→'20	PM109S-WP	* 104,00
800	F 800 R	'05→'20	PM109S	51,80

FILTRI ARIA - AIR FILTERS

CC	Modello Model	Anno Years	Codice Code	€
800	F 800 R (filtro PF1-85)	'05→'20	PM109SF1-85	* 199,00
800	F 800 R (filtro P037)	'05→'20	PM109S-WP	* 104,00
800	F 800 R CHRIS PFEIFFER EDITION	'09→'11	PM109S	51,80
800	F 800 R CHRIS PFEIFFER EDITION (filtro PF1-85)	'09→'11	PM109SF1-85	* 199,00
800	F 800 R CHRIS PFEIFFER EDITION (filtro P037)	'09→'11	PM109S-WP	* 104,00
800	F 800 S	'06→'11	PM109S	51,80
800	F 800 S (filtro PF1-85)	'06→'11	PM109SF1-85	* 199,00
800	F 800 S (filtro P037)	'06→'11	PM109S-WP	* 104,00
800	F 800 ST	'06→'12	PM109S	51,80
800	F 800 ST (filtro PF1-85)	'06→'12	PM109SF1-85	* 199,00
800	F 800 ST (filtro P037)	'06→'12	PM109S-WP	* 104,00
850	F 850 GS	'18→'20	PM188S	78,00
850	F 850 GS (filtro P037)	'18→'20	PM188S-WP	* 156,00
850	F 850 GS (filtro PF1-85)	'18→'20	PM188SF1-85	* 199,00
850	F 850 GS ADVENTURE	'18→'20	PM188S	78,00
850	F 850 GS ADVENTURE (filtro P037)	'18→'20	PM188S-WP	* 156,00
850	F 850 GS ADVENTURE (filtro PF1-85)	'18→'20	PM188SF1-85	* 199,00
850	R 850 R	'94→'07	CM07S	58,00
850	R 850 RT	'96→'01	CM07S	58,00
900	F 900 R	'20→	PM188S	78,00
900	F 900 R (filtro P037)	'20→	PM188S-WP	* 156,00
900	F 900 R (filtro PF1-85)	'20→	PM188SF1-85	* 199,00
900	F 900 XR	'20→	PM188S	78,00
900	F 900 XR (filtro P037)	'20→	PM188S-WP	* 156,00
900	F 900 XR (filtro PF1-85)	'20→	PM188SF1-85	* 199,00
900	R 900 RT	'05→'10	PM35S	50,50
1000	HP4	'13→'14	PM93S	80,60
1000	HP4 (filtro P16)	'13→'14	PM93S16	* 162,00
1000	HP4 (filtro PF1-85)	'13→'14	PM93SF1-85	* 199,00
1000	HP4 RACE	'17→'18	PM93S	80,60
1000	HP4 RACE (filtro P16)	'17→'18	PM93S16	* 162,00
1000	HP4 RACE (filtro PF1-85)	'17→'18	PM93SF1-85	* 199,00
1000	S 1000 R (K47)	'13→'20	PM93S	80,60
1000	S 1000 R (K47) (filtro P16)	'13→'20	PM93S16	* 162,00
1000	S 1000 R (K47) (filtro PF1-85)	'13→'20	PM93SF1-85	* 199,00
1000	S 1000 R (K47 - FORGED WHEELS)	'17→'20	PM93S	80,60
1000	S 1000 R (K47 - FORGED WHEELS) (filtro P16)	'17→'20	PM93S16	* 162,00
1000	S 1000 R (K47 - FORGED WHEELS) (filtro PF1-85)	'17→'20	PM93SF1-85	* 199,00
1000	S 1000 RR (K46)	'09→'18	PM93S	80,60
1000	S 1000 RR (K46) (filtro P16)	'09→'18	PM93S16	* 162,00
1000	S 1000 RR (K46) (filtro PF1-85)	'09→'18	PM93SF1-85	* 199,00
1000	S 1000 RR (K67)	'19→'20	PM171S	81,00
1000	S 1000 RR (K67) (filtro PF1-85)	'19→'20	PM171SF1-85	* 199,00
1000	S 1000 RR (K46) (FORGED WHEELS)	'15→'18	PM93S	80,60
1000	S 1000 RR (K46) (FORGED WHEELS) (filtro P16)	'15→'18	PM93S16	* 162,00
1000	S 1000 RR (K46) (FORGED WHEELS) (filtro PF1-85)	'15→'18	PM93SF1-85	* 199,00
1000	S 1000 XR (K49)	'15→'19	PM93S	80,60
1000	S 1000 XR (K49) (filtro P16)	'15→'19	PM93S16	* 162,00
1000	S 1000 XR (K49) (filtro PF1-85)	'15→'19	PM93SF1-85	* 199,00
1000	S 1000 XR (K69)	'20→	PM171S	81,00
1000	S 1000 XR (K69) (filtro P037)	'20→	PM171S-WP	* 162,00
1000	S 1000 XR (K69) (filtro PF1-85)	'20→	PM171SF1-85	* 199,00
1100	R 1100 GS	'93→'99	CM07S	58,00
1100	R 1100 GS ABS	'93→'99	CM07S	58,00
1100	R 1100 R	'93→'01	CM07S	58,00
1100	R 1100 RS	'92→'01	CM07S	58,00
1100	R 1100 RT	'94→'01	CM07S	58,00
1100	R 1100 RT ABS	'94→'01	CM07S	58,00
1100	R 1100 S	'96→'06	CM07S	58,00
1150	R 1150 GS	'99→'04	CM07S	58,00
1150	R 1150 GS ABS	'99→'04	CM07S	58,00
1150	R 1150 GS ADVENTURE	'02→'05	CM07S	58,00

FILTRI ARIA - AIR FILTERS

CC	Modello Model	Anno Years	Codice Code	€
1150	R 1150 GS ADVENTURE (INTEGRAL ABS)	'02→'05	CM07S	58,00
1150	R 1150 R	'99→'06	CM07S	58,00
1150	R 1150 R ROCKSTER	'03→'06	CM07S	58,00
1150	R 1150 RS	'01→'05	CM07S	58,00
1150	R 1150 RS ABS	'01→'05	CM07S	58,00
1150	R 1150 RT	'00→'06	CM07S	58,00
1150	R 1150 RT ABS	'00→'06	CM07S	58,00
1170	HP2 ENDURO	'05→'08	PM35S	50,50
1170	HP2 ENDURO	'05→'08	PM109S	51,80
1170	HP2 ENDURO (filtro PF1-85)	'05→'08	PM109SF1-85	* 199,00
1170	HP2 ENDURO (filtro P037)	'05→'08	PM109S-WP	* 104,00
1170	HP2 MEGAMOTO	'07→'11	PM35S	50,50
1170	HP2 MEGAMOTO	'07→'11	PM109S	51,80
1170	HP2 MEGAMOTO (filtro PF1-85)	'07→'11	PM109SF1-85	* 199,00
1170	HP2 MEGAMOTO (filtro P037)	'07→'11	PM109S-WP	* 104,00
1170	HP2 SPORT	'08→'11	PM35S	50,50
1170	HP2 SPORT	'08→'11	PM109S	51,80
1170	HP2 SPORT (filtro PF1-85)	'08→'11	PM109SF1-85	* 199,00
1170	HP2 SPORT (filtro P037)	'08→'11	PM109S-WP	* 104,00
1170	R NINET	'13→'20	PM35S	50,50
1170	R NINET	'13→'20	PM109S	51,80
1170	R NINET (filtro PF1-85)	'13→'20	PM109SF1-85	* 199,00
1170	R NINET (filtro P037)	'13→'20	PM109S-WP	* 104,00
1170	R NINET PURE	'17→'20	PM35S	50,50
1170	R NINET PURE	'17→'20	PM109S	51,80
1170	R NINET PURE (filtro PF1-85)	'17→'20	PM109SF1-85	* 199,00
1170	R NINET PURE (filtro P037)	'17→'20	PM109S-WP	* 104,00
1170	R NINET RACER	'17→'20	PM35S	50,50
1170	R NINET RACER	'17→'20	PM109S	51,80
1170	R NINET RACER (filtro PF1-85)	'17→'20	PM109SF1-85	* 199,00
1170	R NINET RACER (filtro P037)	'17→'20	PM109S-WP	* 104,00
1170	R NINET SCRAMBLER	'16→'20	PM35S	50,50
1170	R NINET SCRAMBLER	'16→'20	PM109S	51,80
1170	R NINET SCRAMBLER (filtro PF1-85)	'16→'20	PM109SF1-85	* 199,00
1170	R NINET SCRAMBLER (filtro P037)	'16→'20	PM109S-WP	* 104,00
1170	R NINET URBAN GS	'17→'20	PM35S	50,50
1170	R NINET URBAN GS	'17→'20	PM109S	51,80
1170	R NINET URBAN GS (filtro PF1-85)	'17→'20	PM109SF1-85	* 199,00
1170	R NINET URBAN GS (filtro P037)	'17→'20	PM109S-WP	* 104,00
1200	K 1200 GT	'06→'08	PM85S	60,00
1200	K 1200 R	'05→'08	PM85S	60,00
1200	K 1200 R SPORT	'07→'11	PM85S	60,00
1200	K 1200 S (2 required)	'03→'08	PM85S	60,00
1200	R 1200 C	'97→'05	CM08S	51,90
1200	R 1200 C ABS	'97→'05	CM08S	51,90
1200	R 1200 C CLASSIC	'03	CM08S	51,90
1200	R 1200 C INDIPENDENT	'00→'04	CM08S	51,90
1200	R 1200 C MONTAUK	'04	CM08S	51,90
1200	R 1200 CL	'02→'04	CM08S	51,90
1200	R 1200 GS	'04→'12	PM35S	50,50
1200	R 1200 GS	'04→'12	PM109S	51,80
1200	R 1200 GS (filtro PF1-85)	'04→'12	PM109SF1-85	* 199,00
1200	R 1200 GS (filtro P037)	'04→'12	PM109S-WP	* 104,00
1200	R 1200 GS	'13→'18	PM142S	70,00
1200	R 1200 GS (filtro P037)	'13→'18	PM142S-WP	* 140,00
1200	R 1200 GS ADVENTURE	'06→'13	PM35S	50,50
1200	R 1200 GS ADVENTURE	'06→'13	PM109S	51,80
1200	R 1200 GS ADVENTURE (filtro PF1-85)	'06→'13	PM109SF1-85	* 199,00
1200	R 1200 GS ADVENTURE (filtro P037)	'06→'13	PM109S-WP	* 104,00
1200	R 1200 GS ADVENTURE	'14→'18	PM142S	70,00
1200	R 1200 GS ADVENTURE (filtro P037)	'14→'18	PM142S-WP	* 140,00
1200	R 1200 GS RALLY	'12	PM35S	50,50

FILTRI ARIA - AIR FILTERS

CC	Modello Model	Anno Years	Codice Code	€
1200	R 1200 GS RALLY	'12	PM109S	51,80
1200	R 1200 GS RALLY (filtro PF1-85)	'12	PM109SF1-85	* 199,00
1200	R 1200 GS RALLY (filtro P037)	'12	PM109S-WP	* 104,00
1200	R 1200 GS RALLYE	'17→'18	PM142S	70,00
1200	R 1200 GS RALLYE (filtro P037)	'17→'18	PM142S-WP	* 140,00
1200	R 1200 GS RALLYE (filtro PF1-85)	'17→'18	PM142SF1-85	* 199,00
1200	R 1200 R	'14→'18	PM142S	70,00
1200	R 1200 R (filtro P037)	'14→'18	PM142S-WP	* 140,00
1200	R 1200 R (filtro PF1-85)	'14→'18	PM142SF1-85	* 199,00
1200	R 1200 R CLASSIC	'11→'12	PM35S	50,50
1200	R 1200 RS	'15→'18	PM142S	70,00
1200	R 1200 RS (filtro P037)	'15→'18	PM142S-WP	* 140,00
1200	R 1200 RS (filtro PF1-85)	'15→'18	PM142SF1-85	* 199,00
1200	R 1200 RT	'05→'13	PM35S	50,50
1200	R 1200 RT	'14→'18	PM142S	70,00
1200	R 1200 RT (filtro P037)	'14→'18	PM142S-WP	* 140,00
1200	R 1200 RT (filtro PF1-85)	'14→'18	PM142SF1-85	* 199,00
1200	R 1200 S	'05→'08	PM35S	50,50
1200	R 1200 ST	'03→'08	PM35S	50,50
1250	R 1250 GS	'19→'20	PM142S	70,00
1250	R 1250 GS (filtro P037)	'19→'20	PM142S-WP	* 140,00
1250	R 1250 GS (filtro PF1-85)	'19→'20	PM142SF1-85	* 199,00
1250	R 1250 GS ADVENTURE	'19→'20	PM142S	70,00
1250	R 1250 GS ADVENTURE (filtro P037)	'19→'20	PM142S-WP	* 140,00
1250	R 1250 GS ADVENTURE (filtro PF1-85)	'19→'20	PM142SF1-85	* 199,00
1250	R 1250 R	'19→'20	PM142S	70,00
1250	R 1250 R (filtro P037)	'19→'20	PM142S-WP	* 140,00
1250	R 1250 R (filtro PF1-85)	'19→'20	PM142SF1-85	* 199,00
1250	R 1250 RS	'19→'20	PM142S	70,00
1250	R 1250 RS (filtro P037)	'19→'20	PM142S-WP	* 140,00
1250	R 1250 RS (filtro PF1-85)	'19→'20	PM142SF1-85	* 199,00
1250	R 1250 RT	'19→'20	PM142S	70,00
1250	R 1250 RT (filtro P037)	'19→'20	PM142S-WP	* 140,00
1250	R 1250 RT (filtro PF1-85)	'19→'20	PM142SF1-85	* 199,00
1250	R 1250 RT SPORT	'19→'20	PM142S	70,00
1250	R 1250 RT SPORT (filtro P037)	'19→'20	PM142S-WP	* 140,00
1250	R 1250 RT SPORT (filtro PF1-85)	'19→'20	PM142SF1-85	* 199,00
1300	K 1300 GT	'09→'11	PM85S	60,00
1300	K 1300 R	'07→'12	PM85S	60,00
1300	K 1300 S (2 required)	'07→'16	PM85S	60,00
1600	K 1600 BAGGER	'17→'20	PM187S	84,00
1600	K 1600 BAGGER (filtro P037)	'17→'20	PM187S-WP	* 168,00
1600	K 1600 BAGGER (filtro PF1-85)	'17→'20	PM187SF1-85	* 199,00
1600	K 1600 GRAND AMERICA	'18→'20	PM187S	84,00
1600	K 1600 GRAND AMERICA (filtro P037)	'18→'20	PM187S-WP	* 168,00
1600	K 1600 GRAND AMERICA (filtro PF1-85)	'18→'20	PM187SF1-85	* 199,00
1600	K 1600 GT	'11→'20	PM187S	84,00
1600	K 1600 GT (filtro P037)	'11→'20	PM187S-WP	* 168,00
1600	K 1600 GT (filtro PF1-85)	'11→'20	PM187SF1-85	* 199,00
1600	K 1600 GTL	'11→'18	PM187S	84,00
1600	K 1600 GTL (filtro P037)	'11→'18	PM187S-WP	* 168,00
1600	K 1600 GTL (filtro PF1-85)	'11→'18	PM187SF1-85	* 199,00
1600	K 1600 GTL EXCLUSIVE	'13→'16	PM187S	84,00
1600	K 1600 GTL EXCLUSIVE (filtro P037)	'13→'16	PM187S-WP	* 168,00
1600	K 1600 GTL EXCLUSIVE (filtro PF1-85)	'13→'16	PM187SF1-85	* 199,00

(*) Questi articoli non hanno la solita scontistica ma un prezzo netto per il rivenditore.

BUELL

1125	CR	'09→'10	PM41S	110,00
1125	R	'08→'10	PM41S	110,00
1168	M2 CYCLONE	'97→'02	OM09S	61,29
1168	S1 LIGHTNING	'97→'99	OM09S	61,29

FILTRI ARIA - AIR FILTERS

CC	Modello Model	Anno Years	Codice Code	€
1200	S1 WHITE LIGHTNING	'98→'99	OM09S	61,29
1200	S3 THUNDERBOLT	'97→'99	OM09S	61,29
1200	S3T THUNDERBOLT	'97→'99	OM09S	61,29
1200	X1 LIGHTNING	'99→'02	OM09S	61,29

CAGIVA

900	GRAN CANYON IE	'98→'00	P031S	60,00
1000	NAVIGATOR	'00→'05	P031S	60,00
1000	RAPTOR	'00→'05	CM97S	54,72
1000	V-RAPTOR	'00→'05	CM97S	54,72
1000	X-TRA RAPTOR	'00→'05	CM97S	54,72

DUCATI

400	MONSTER	'95→'97	P106S	61,29
400	MONSTER	'02→'04	PM10S	61,29
400	MONSTER DARK	'05→'05	PM10S	61,29
400	MONSTER (JAPAN)	'07→'08	PM10S	61,29
400	SCRAMBLER SIXTY 2	'17→'20	CM61S	71,00
400	SCRAMBLER SISTY 2 (filtro PF1-85)	'17→'20	CM61SF1-85	* 199,00
400	SCRAMBLER SIXTY 2 (filtro P037)	'17→'20	CM61S-WP	* 142,00
400	SUPERSPORT	'93→'97	P106S	61,29
600	MONSTER	'93→'01	PM121S	61,29
600	MONSTER CITY	'98→'01	PM121S	61,29
600	MONSTER DARK	'98→'01	PM121S	61,29
600	MONSTER DARK CITY	'98→'01	PM121S	61,29
600	SUPERSPORT	'91→'98	PM121S	61,29
620	MONSTER (1° serie)	'02→'05	PM10S	61,29
620	MONSTER (2° serie)	'05→'06	PM10S	61,29
620	MONSTER DARK (1° serie)	'03→'05	PM10S	61,29
620	MONSTER DARK (2° serie)	'05→'06	PM10S	61,29
620	MULTISTRADA	'05→'06	PM12S	71,00
620	MULTISTRADA DARK	'05→'06	PM12S	71,00
620	SUPERSPORT S	'03	P106S	61,29
695	MONSTER	'06→'08	PM10S	61,29
696	MONSTER	'08→'13	CM61S	71,00
696	MONSTER (filtro PF1-85)	'08→'13	CM61SF1-85	* 199,00
696	MONSTER (filtro P037)	'08→'13	CM61S-WP	* 142,00
696	MONSTER ABS	'08→'13	CM61S	71,00
696	MONSTER ABS (filtro PF1-85)	'08→'13	CM61SF1-85	* 199,00
696	MONSTER ABS (filtro P037)	'08→'13	CM61S-WP	* 142,00
696	MONSTER +	'09→'14	CM61S	71,00
696	MONSTER + (filtro PF1-85)	'09→'14	CM61SF1-85	* 199,00
696	MONSTER + (filtro P037)	'09→'14	CM61S-WP	* 142,00
696	MONSTER + ABS	'09→'14	CM61S	71,00
696	MONSTER + ABS (filtro PF1-85)	'09→'14	CM61SF1-85	* 199,00
696	MONSTER + ABS (filtro P037)	'09→'14	CM61S-WP	* 142,00
696	MONSTER ANNIVERSARY + ABS	'13	CM61S	71,00
696	MONSTER ANNIVERSARY + ABS (filtro PF1-85)	'13	CM61SF1-85	* 199,00
696	MONSTER ANNIVERSARY + ABS (filtro P037)	'13	CM61S-WP	* 142,00
750	MONSTER (BIDISCO)	'96→'01	PM121S	61,29
750	MONSTER (BIDISCO)	'02	PM10S	61,29
750	MONSTER (MONODISCO)	'96→'97	PM121S	61,29
750	MONSTER CITY	'99	PM121S	61,29
750	MONSTER CITY DARK	'99	PM121S	61,29
750	MONSTER DARK	'99→'01	PM121S	61,29
750	MONSTER DARK	'02	PM10S	61,29
750	PASO	'87→'88	PM121S	61,29
750	SPORT IE	'01→'02	PM121S	61,29
750	SS	'91→'98	PM121S	61,29
750	SUPERSPORT IE	'99→'02	PM121S	61,29
795	MONSTER	'12→'15	CM61S	71,00
795	MONSTER (filtro PF1-85)	'12→'15	CM61SF1-85	* 199,00
795	MONSTER (filtro P037)	'12→'15	CM61S-WP	* 142,00

FILTRI ARIA - AIR FILTERS

CC	Modello Model	Anno Years	Codice Code	€
795	MONSTER ABS	'13→'15	CM61S	71,00
795	MONSTER ABS (filtro PF1-85)	'13→'15	CM61SF1-85	* 199,00
795	MONSTER ABS (filtro P037)	'13→'15	CM61S-WP	* 142,00
795	MONSTER ABS CORSE STRIPE	'14→'15	CM61S	71,00
795	MONSTER ABS CORSE STRIPE (filtro PF1-85)	'14→'15	CM61SF1-85	* 199,00
795	MONSTER ABS CORSE STRIPE (filtro P037)	'14→'15	CM61S-WP	* 142,00
796	HYPERMOTARD	'10→'12	CM61S	71,00
796	HYPERMOTARD (filtro PF1-85)	'10→'12	CM61SF1-85	* 199,00
796	HYPERMOTARD (filtro P037)	'10→'12	CM61S-WP	* 142,00
796	MONSTER	'10→'13	CM61S	71,00
796	MONSTER (filtro PF1-85)	'10→'13	CM61SF1-85	* 199,00
796	MONSTER (filtro P037)	'10→'13	CM61S-WP	* 142,00
796	MONSTER ABS	'10→'14	CM61S	71,00
796	MONSTER ABS (filtro PF1-85)	'10→'14	CM61SF1-85	* 199,00
796	MONSTER ABS (filtro P037)	'10→'14	CM61S-WP	* 142,00
796	MONSTER ABS ANNIVERSARY	'13	CM61S	71,00
796	MONSTER ABS ANNIVERSARY (filtro PF1-85)	'13	CM61SF1-85	* 199,00
796	MONSTER ABS ANNIVERSARY (filtro P037)	'13	CM61S-WP	* 142,00
797	MONSTER	'17→'19	CM61S	71,00
797	MONSTER (filtro PF1-85)	'17→'19	CM61SF1-85	* 199,00
797	MONSTER (filtro P037)	'17→'19	CM61S-WP	* 142,00
797	MONSTER +	'17→'19	CM61S	71,00
797	MONSTER + (filtro PF1-85)	'17→'19	CM61SF1-85	* 199,00
797	MONSTER + (filtro P037)	'17→'19	CM61S-WP	* 142,00
800	MONSTER	'03→'04	PM10S	61,29
800	MONSTER DARK	'03	PM10S	61,29
800	MONSTER S	'03→'04	PM10S	61,29
800	MONSTER S2R	'05→'07	PM10S	61,29
800	MONSTER S2R DARK	'05→'06	PM10S	61,29
800	SUPERSPORT	'03→'05	P106S	61,29
800	SUPERSPORT S	'03	P106S	61,29
803	SCRAMBLER CAFE' RACER	'17→'20	CM61S	71,00
803	SCRAMBLER CAFE' RACER (filtro PF1-85)	'17→'20	CM61SF1-85	* 199,00
803	SCRAMBLER CAFE' RACER (filtro P037)	'17→'20	CM61S-WP	* 142,00
803	SCRAMBLER CLASSIC	'15→'18	CM61S	71,00
803	SCRAMBLER CLASSIC (filtro PF1-85)	'15→'18	CM61SF1-85	* 199,00
803	SCRAMBLER CLASSIC (filtro P037)	'15→'18	CM61S-WP	* 142,00
803	SCRAMBLER DESERT SLED	'17→'20	CM61S	71,00
803	SCRAMBLER DESERT SLED (filtro PF1-85)	'17→'20	CM61SF1-85	* 199,00
803	SCRAMBLER DESERT SLED (filtro P037)	'17→'20	CM61S-WP	* 142,00
803	SCRAMBLER FLAT TRACK PRO	'16	CM61S	71,00
803	SCRAMBLER FLAT TRACK PRO (filtro PF1-85)	'16	CM61SF1-85	* 199,00
803	SCRAMBLER FLAT TRACK PRO (filtro P037)	'16	CM61S-WP	* 142,00
803	SCRAMBLER FULL THROTTLE	'15→'20	CM61S	71,00
803	SCRAMBLER FULL THROTTLE (filtro PF1-85)	'15→'20	CM61SF1-85	* 199,00
803	SCRAMBLER FULL THROTTLE (filtro P037)	'15→'20	CM61S-WP	* 142,00
803	SCRAMBLER ICON	'15→'20	CM61S	71,00
803	SCRAMBLER ICON (filtro PF1-85)	'15→'20	CM61SF1-85	* 199,00
803	SCRAMBLER ICON (filtro P037)	'15→'20	CM61S-WP	* 142,00
803	SCRAMBLER MACH 2.0	'18	CM61S	71,00
803	SCRAMBLER MACH 2.0 (filtro PF1-85)	'18	CM61SF1-85	* 199,00
803	SCRAMBLER MACH 2.0 (filtro P037)	'18	CM61S-WP	* 142,00
803	SCRAMBLER SCR	'20	CM61S	71,00
803	SCRAMBLER SCR (filtro PF1-85)	'20	CM61SF1-85	* 199,00
803	SCRAMBLER SCR (filtro P037)	'20	CM61S-WP	* 142,00
803	SCRAMBLER STREET CLASSIC	'18	CM61S	71,00
803	SCRAMBLER STREET CLASSIC (filtro PF1-85)	'18	CM61SF1-85	* 199,00
803	SCRAMBLER STREET CLASSIC (filtro P037)	'18	CM61S-WP	* 142,00
803	SCRAMBLER URBAN ENDURO	'15→'16	CM61S	71,00
803	SCRAMBLER URBAN ENDURO (filtro PF1-85)	'15→'16	CM61SF1-85	* 199,00
803	SCRAMBLER URBAN ENDURO (filtro P037)	'15→'16	CM61S-WP	* 142,00
821	HYPERMOTARD	'13→'15	CM61S	71,00
821	HYPERMOTARD (filtro PF1-85)	'13→'15	CM61SF1-85	* 199,00

FILTRI ARIA - AIR FILTERS

CC	Modello Model	Anno Years	Codice Code	€
821	HYPERMOTARD (filtro P037)	'13→'15	CM61S-WP	* 142,00
821	HYPERMOTARD SP	'13→'15	CM61S	71,00
821	HYPERMOTARD SP (filtro PF1-85)	'13→'15	CM61SF1-85	* 199,00
821	HYPERMOTARD SP (filtro P037)	'13→'15	CM61S-WP	* 142,00
821	HYPERSTRADA	'13→'15	CM61S	71,00
821	HYPERSTRADA (filtro PF1-85)	'13→'15	CM61SF1-85	* 199,00
821	HYPERSTRADA (filtro P037)	'13→'15	CM61S-WP	* 142,00
821	MONSTER	'14→'20	CM61S	71,00
821	MONSTER (filtro PF1-85)	'14→'20	CM61SF1-85	* 199,00
821	MONSTER (filtro P037)	'14→'20	CM61S-WP	* 142,00
821	MONSTER DARK	'15→'18	CM61S	71,00
821	MONSTER DARK (filtro PF1-85)	'15→'18	CM61SF1-85	* 199,00
821	MONSTER DARK (filtro P037)	'15→'18	CM61S-WP	* 142,00
821	MONSTER STEALTH	'19→'20	CM61S	71,00
821	MONSTER STEALTH (filtro PF1-85)	'19→'20	CM61SF1-85	* 199,00
821	MONSTER STEALTH (filtro P037)	'19→'20	CM61S-WP	* 142,00
821	MONSTER STRIPE	'15→'18	CM61S	71,00
821	MONSTER STRIPE (filtro PF1-85)	'15→'18	CM61SF1-85	* 199,00
821	MONSTER STRIPE (filtro P037)	'15→'18	CM61S-WP	* 142,00
848	848	'07→'13	CM13S	78,75
848	848 EVO	'10→'13	CM13S	78,75
848	848 EVO CORSE SPECIAL EDITION	'11→'13	CM13S	78,75
848	STREETFIGHTER	'11→'15	CM13S	78,75
851	851	'91→'92	P106S	61,29
888	888 SUPERBIKE STRADA SP	'94→'95	P106S	61,29
888	888 SUPERBIKE STRADA SP4	'92→'92	P106S	61,29
888	888 SUPERBIKE STRADA SP5	'93→'95	P106S	61,29
899	PANIGALE	'14→'15	PM127S	86,00
899	PANIGALE (filtro P16)	'14→'15	PM127S16	* 172,00
899	PANIGALE (filtro P037)	'14→'15	PM127S-WP	* 192,00
899	PANIGALE (filtro PF1-85)	'14→'15	PM127SF1-85	* 199,00
899	PANIGALE (filtro P16 Aviofiber)	'14→'15	R127STK	* 300,00
899	PANIGALE (filtro P16 Carbon Fiber)	'14→'15	R127SBK	* 300,00
900	MONSTER	'93→'98	PM121S	61,29
900	MONSTER CITY	'99	P106S	61,29
900	MONSTER CITY DARK	'99	P106S	61,29
900	MONSTER CITY DARK IE	'00→'01	P106S	61,29
900	MONSTER CITY DARK IE	'02	PM10S	61,29
900	MONSTER CITY IE	'00→'01	P106S	61,29
900	MONSTER CITY IE	'02	PM10S	61,29
900	MONSTER CROMO	'98	PM121S	61,29
900	MONSTER CROMO	'99	P106S	61,29
900	MONSTER CROMO IE	'00→'01	P106S	61,29
900	MONSTER CROMO IE	'02	PM10S	61,29
900	MONSTER DARK	'99→'99	P106S	61,29
900	MONSTER DARK IE	'00→'01	P106S	61,29
900	MONSTER DARK IE	'02	PM10S	61,29
900	MONSTER IE	'99→'01	P106S	61,29
900	MONSTER IE	'02	PM10S	61,29
900	MONSTER METALLIC IE	'00→'01	P106S	61,29
900	MONSTER S	'98→'99	PM121S	61,29
900	MONSTER S IE	'00→'01	P106S	61,29
900	MONSTER S IE	'02	PM10S	61,29
900	SPORT IE	'02	PM121S	61,29
900	SS SUPER LIGHT	'92→'96	PM121S	61,29
900	SUPERSPORT	'89→'97	PM121S	61,29
900	SUPERSPORT FE	'97→'98	PM121S	61,29
900	SUPERSPORT IE	'98→'01	P106S	61,29
900	SUPERSPORT IE	'02→'02	PM121S	61,29
900	907 I.E.	'90→'93	P106S	61,29
916	MONSTER S4	'01→'02	PM10S	61,29
916	MONSTER S4 FOGGY	'02	PM10S	61,29
916	ST4	'99→'03	P106S	61,29

FILTRI ARIA - AIR FILTERS

CC	Modello Model	Anno Years	Codice Code	€
939	HYPERMOTARD	'16→'18	CM61S	71,00
939	HYPERMOTARD (filtro PF1-85)	'16→'18	CM61SF1-85	* 199,00
939	HYPERMOTARD (filtro P037)	'16→'18	CM61S-WP	* 142,00
939	HYPERMOTARD SP	'16→'18	CM61S	71,00
939	HYPERMOTARD SP (filtro PF1-85)	'16→'18	CM61SF1-85	* 199,00
939	HYPERMOTARD SP (filtro P037)	'16→'18	CM61S-WP	* 142,00
939	HYPERSTRADA	'16→'18	CM61S	71,00
939	HYPERSTRADA (filtro PF1-85)	'16→'18	CM61SF1-85	* 199,00
939	HYPERSTRADA (filtro P037)	'16→'18	CM61S-WP	* 142,00
939	SUPERSPORT	'17→'19	CM61S	71,00
939	SUPERSPORT (filtro PF1-85)	'17→'19	CM61SF1-85	* 199,00
939	SUPERSPORT (filtro P037)	'17→'19	CM61S-WP	* 142,00
939	SUPERSPORT S	'17→'19	CM61S	71,00
939	SUPERSPORT S (filtro PF1-85)	'17→'19	CM61SF1-85	* 199,00
939	SUPERSPORT S (filtro P037)	'17→'19	CM61S-WP	* 142,00
944	ST2	'97→'03	P106S	61,29
950	HYPERMOTARD	'19→'20	CM61S	71,00
950	HYPERMOTARD (filtro PF1-85)	'19→'20	CM61SF1-85	* 199,00
950	HYPERMOTARD (filtro P037)	'19→'20	CM61S-WP	* 142,00
950	HYPERMOTARD SP	'19→'20	CM61S	71,00
950	HYPERMOTARD SP (filtro PF1-85)	'19→'20	CM61SF1-85	* 199,00
950	HYPERMOTARD SP (filtro P037)	'19→'20	CM61S-WP	* 142,00
950	MULTISTRADA	'17→'20	PM127S	86,00
950	MULTISTRADA (filtro P16)	'17→'20	PM127S16	* 172,00
950	MULTISTRADA (filtro P037)	'17→'20	PM127S-WP	* 192,00
950	MULTISTRADA (filtro PF1-85)	'17→'20	PM127SF1-85	* 199,00
950	MULTISTRADA S	'19→'20	PM127S	86,00
950	MULTISTRADA S (filtro P16)	'19→'20	PM127S16	* 172,00
950	MULTISTRADA S (filtro P037)	'19→'20	PM127S-WP	* 192,00
950	MULTISTRADA S (filtro PF1-85)	'17→'20	PM127SF1-85	* 199,00
899	PANIGALE	'14→'15	PM127S	86,00
899	PANIGALE (filtro P16)	'14→'15	PM127S16	* 172,00
899	PANIGALE (filtro P037)	'14→'15	PM127S-WP	* 192,00
899	PANIGALE (filtro PF1-85)	'14→'15	PM127SF1-85	* 199,00
955	PANIGALE V2	'20→	PM127S	86,00
955	PANIGALE V2 (filtro P16)	'20→	PM127S16	* 172,00
955	PANIGALE V2 (filtro P037)	'20→	PM127S-WP	* 192,00
955	PANIGALE V2 (filtro PF1-85)	'20→	PM127SF1-85	* 199,00
959	PANIGALE	'16→'19	PM127S	86,00
959	PANIGALE (filtro P16)	'16→'19	PM127S16	* 172,00
959	PANIGALE (filtro P037)	'16→'19	PM127S-WP	* 192,00
959	PANIGALE (filtro PF1-85)	'16→'19	PM127SF1-85	* 199,00
959	PANIGALE (filtro P16 Aviofiber)	'16→'19	R127STK	* 300,00
959	PANIGALE (filtro P16 Carbon Fiber)	'16→'19	R127SBK	* 300,00
959	PANIGALE CORSE	'18→'19	PM127S	86,00
959	PANIGALE CORSE (filtro P16)	'16→'19	PM127S16	* 172,00
959	PANIGALE CORSE (filtro PF1-85)	'16→'19	PM127SF1-85	* 199,00
959	PANIGALE CORSE (filtro P16 Aviofiber)	'16→'19	R127STK	* 300,00
959	PANIGALE CORSE (filtro P16 Carbon Fiber)	'16→'19	R127SBK	* 300,00
992	ST3	'04→'07	P106S	61,29
992	ST3 ABS	'06→'07	P106S	61,29
992	ST3 S ABS	'06→'07	P106S	61,29
996	MONSTER S4R	'03→'06	PM10S	61,29
996	ST4 S	'01→'05	P106S	61,29
996	ST4 S ABS	'03→'05	P106S	61,29
996	MONSTER S4R Testastretta	'07→'08	PM10S	61,29
996	MONSTER S4RS Testastretta	'06→'08	PM10S	61,29
1000	MONSTER	'03→'05	PM10S	61,29
1000	MONSTER S	'03→'05	PM10S	61,29
1000	MONSTER S2R	'06→'08	PM10S	61,29
1000	MULTISTRADA DS	'03→'06	PM12S	71,00
1000	MULTISTRADA S DS	'03→'06	PM12S	71,00
1000	PANIGALE V4R	'19→'20	PM160S	88,00

FILTRI ARIA - AIR FILTERS

CC	Modello Model	Anno Years	Codice Code	€
1000	PANIGALE V4R (filtro PF1-85)	'19→'20	PM160SF1-85	* 199,00
1000	PAUL SMART LE	'06→'08	CM61S	71,00
1000	PAUL SMART LE (filtro PF1-85)	'06→'08	CM61SF1-85	* 199,00
1000	PAUL SMART LE (filtro P037)	'06→'08	CM61S-WP	* 142,00
1000	SPORTCLASSIC	'06→'08	CM61S	71,00
1000	SPORTCLASSIC (filtro PF1-85)	'06→'08	CM61SF1-85	* 199,00
1000	SPORTCLASSIC (filtro P037)	'06→'08	CM61S-WP	* 142,00
1000	SPORTCLASSIC GT	'06→'12	CM61S	71,00
1000	SPORTCLASSIC GT (filtro PF1-85)	'06→'12	CM61SF1-85	* 199,00
1000	SPORTCLASSIC GT (filtro P037)	'06→'12	CM61S-WP	* 142,00
1000	SPORTCLASSIC GT TOURING	'06→'12	CM61S	71,00
1000	SPORTCLASSIC GT TOURING (filtro PF1-85)	'06→'12	CM61SF1-85	* 199,00
1000	SPORTCLASSIC GT TOURING (filtro P037)	'06→'12	CM61S-WP	* 142,00
1000	SPORTCLASSIC S	'06→'11	CM61S	71,00
1000	SPORTCLASSIC S (filtro PF1-85)	'06→'11	CM61SF1-85	* 199,00
1000	SPORTCLASSIC S (filtro P037)	'06→'11	CM61S-WP	* 142,00
1000	SUPERSPORT	'03→'06	P106S	61,29
1000	SUPERSPORT DS	'04→'06	P106S	61,29
1098		'06→'09	CM13S	78,75
1098	S	'06→'11	CM13S	78,75
1098	1098 S TRICOLORE	'07→'07	CM13S	78,75
1100	HYPERMOTARD	'08→'09	CM61S	71,00
1100	HYPERMOTARD (filtro PF1-85)	'08→'09	CM61SF1-85	* 199,00
1100	HYPERMOTARD (filtro P037)	'08→'09	CM61S-WP	* 142,00
1100	HYPERMOTARD EVO	'10→'12	CM61S	71,00
1100	HYPERMOTARD EVO (filtro PF1-85)	'10→'12	CM61SF1-85	* 199,00
1100	HYPERMOTARD EVO (filtro P037)	'10→'12	CM61S-WP	* 142,00
1100	HYPERMOTARD EVO SP	'10→'12	CM61S	71,00
1100	HYPERMOTARD EVO SP (filtro PF1-85)	'10→'12	CM61SF1-85	* 199,00
1100	HYPERMOTARD EVO SP (filtro P037)	'10→'12	CM61S-WP	* 142,00
1100	HYPERMOTARD S	'07→'09	CM61S	71,00
1100	HYPERMOTARD S (filtro PF1-85)	'07→'09	CM61SF1-85	* 199,00
1100	HYPERMOTARD S (filtro P037)	'07→'09	CM61S-WP	* 142,00
1100	MONSTER	'09→'10	CM61S	71,00
1100	MONSTER (filtro PF1-85)	'09→'10	CM61SF1-85	* 199,00
1100	MONSTER (filtro P037)	'09→'10	CM61S-WP	* 142,00
1100	MONSTER ABS	'10→'10	CM61S	71,00
1100	MONSTER ABS (filtro PF1-85)	'10	CM61SF1-85	* 199,00
1100	MONSTER ABS (filtro P037)	'10	CM61S-WP	* 142,00
1100	MONSTER DIESEL	'13	CM61S	71,00
1100	MONSTER DIESEL (filtro PF1-85)	'13	CM61SF1-85	* 199,00
1100	MONSTER DIESEL (filtro P037)	'13	CM61S-WP	* 142,00
1100	MONSTER EVO ABS	'11→'13	CM61S	71,00
1100	MONSTER EVO ABS (filtro PF1-85)	'11→'13	CM61SF1-85	* 199,00
1100	MONSTER EVO ABS (filtro P037)	'11→'13	CM61S-WP	* 142,00
1100	MONSTER EVO ANNIVERSARY	'13	CM61S	71,00
1100	MONSTER EVO ANNIVERSARY (filtro PF1-85)	'13	CM61SF1-85	* 199,00
1100	MONSTER EVO ANNIVERSARY (filtro P037)	'13	CM61S-WP	* 142,00
1100	MONSTER S	'09→'10	CM61S	71,00
1100	MONSTER S (filtro PF1-85)	'09→'10	CM61SF1-85	* 199,00
1100	MONSTER S (filtro P037)	'09→'10	CM61S-WP	* 142,00
1100	MONSTER S ABS	'10	CM61S	71,00
1100	MONSTER S ABS (filtro PF1-85)	'10	CM61SF1-85	* 199,00
1100	MONSTER S ABS (filtro P037)	'10	CM61S-WP	* 142,00
1100	MULTISTRADA	'07→'09	PM12S	71,00
1100	MULTISTRADA S	'07→'09	PM12S	71,00
1100	SCRAMBLER	'18→'20	PM127S	86,00
1100	SCRAMBLER (filtro P16)	'18→'20	PM127S16	* 172,00
1100	SCRAMBLER (filtro PF1-85)	'18→'20	PM127SF1-85	* 199,00
1100	SCRAMBLER (filtro P037)	'18→'20	PM127S-WP	* 192,00
1100	SCRAMBLER SPECIAL	'18→'20	PM127S	86,00
1100	SCRAMBLER SPECIAL (filtro P16)	'18→'20	PM127S16	* 172,00
1100	SCRAMBLER SPECIAL (filtro PF1-85)	'18→'20	PM127SF1-85	* 199,00

FILTRI ARIA - AIR FILTERS

CC	Modello Model	Anno Years	Codice Code	€
1100	SCRAMBLER SPECIAL (filtro P037)	'18→'20	PM127S-WP	* 192,00
1100	SCRAMBLER SPORT	'18→'20	PM127S	86,00
1100	SCRAMBLER SPORT (filtro P16)	'18→'20	PM127S16	* 172,00
1100	SCRAMBLER SPORT (filtro PF1-85)	'18→'20	PM127SF1-85	* 199,00
1100	SCRAMBLER SPORT (filtro P037)	'18→'20	PM127S-WP	* 192,00
1100	STREETFIGHTER	'09→'11	CM13S	78,75
1100	STREETFIGHTER S	'09→'13	CM13S	78,75
1100	STREETFIGHTER V4	'20→	PM160S	88,00
1100	STREETFIGHTER V4 (filtro PF1-85)	'20→	PM160SF1-85	* 199,00
1100	STREETFIGHTER V4 S	'20→	PM160S	88,00
1100	STREETFIGHTER V4 S (filtro PF1-85)	'20→	PM160SF1-85	* 199,00
1103	PANIGALE V4	'18→'20	PM160S	88,00
1103	PANIGALE V4 (filtro PF1-85)	'18→'20	PM160SF1-85	* 199,00
1103	PANIGALE V4 S	'18→'20	PM160S	88,00
1103	PANIGALE V4 S (filtro PF1-85)	'18→'20	PM160SF1-85	* 199,00
1103	PANIGALE V4 S CORSE	'19	PM160S	88,00
1103	PANIGALE V4 S CORSE (filtro PF1-85)	'19	PM160SF1-85	* 199,00
1103	PANIGALE V4 SPECIALE	'18→'19	PM160S	88,00
1103	PANIGALE V4 SPECIALE (filtro PF1-85)	'18→'19	PM160SF1-85	* 199,00
1198	1198	'09→'12	CM13S	78,75
1198	1098 R	'07→'11	CM13S	78,75
1198	1098 R BAYLISS	'09→'11	CM13S	78,75
1198	1198 R CORSE SPECIAL EDITION	'10→'12	CM13S	78,75
1198	1198 S	'08→'12	CM13S	78,75
1198	1198 S CORSE SPECIAL EDITION	'10→'12	CM13S	78,75
1198	1198 SP	'11→'12	CM13S	78,75
1199	PANIGALE	'12→'13	PM127S	86,00
1199	PANIGALE (filtro P16)	'12→'13	PM127S16	* 172,00
1199	PANIGALE (filtro P037)	'12→'13	PM127S-WP	* 192,00
1199	PANIGALE (filtro PF1-85)	'12→'13	PM127SF1-85	* 199,00
1199	PANIGALE (filtro P16 Aviofiber)	'12→'14	R127STK	* 300,00
1199	PANIGALE (filtro P16 Carbon Fiber)	'12→'14	R127SBK	* 300,00
1199	PANIGALE ABS	'13→'14	PM127S	86,00
1199	PANIGALE ABS (filtro P16)	'13→'14	PM127S16	* 172,00
1199	PANIGALE ABS (filtro P037)	'13→'14	PM127S-WP	* 192,00
1199	PANIGALE ABS (filtro PF1-85)	'13→'14	PM127SF1-85	* 199,00
1199	PANIGALE ABS (filtro P16 Aviofiber)	'12→'14	R127STK	* 300,00
1199	PANIGALE ABS (filtro P16 Carbon Fiber)	'12→'14	R127SBK	* 300,00
1199	PANIGALE R	'13→'17	PM127S	86,00
1199	PANIGALE R (filtro P16)	'13→'17	PM127S16	* 172,00
1199	PANIGALE R (filtro P037)	'13→'17	PM127S-WP	* 192,00
1199	PANIGALE R (filtro PF1-85)	'13→'17	PM127SF1-85	* 199,00
1199	PANIGALE R (filtro P16 Aviofiber)	'12→'14	R127STK	* 300,00
1199	PANIGALE R (filtro P16 Carbon Fiber)	'12→'14	R127SBK	* 300,00
1199	PANIGALE S	'13→'14	PM127S	86,00
1199	PANIGALE S (filtro P16)	'13→'14	PM127S16	* 172,00
1199	PANIGALE S (filtro P037)	'13→'14	PM127S-WP	* 192,00
1199	PANIGALE S (filtro PF1-85)	'13→'14	PM127SF1-85	* 199,00
1199	PANIGALE S (filtro P16 Aviofiber)	'13→'14	R127STK	* 300,00
1199	PANIGALE S (filtro P16 Carbon Fiber)	'13→'14	R127SBK	* 300,00
1199	PANIGALE S ABS	'13→'14	PM127S	86,00
1199	PANIGALE S ABS (filtro P16)	'13→'14	PM127S16	* 172,00
1199	PANIGALE S ABS (filtro P037)	'13→'14	PM127S-WP	* 192,00
1199	PANIGALE S ABS (filtro PF1-85)	'13→'14	PM127SF1-85	* 199,00
1199	PANIGALE S ABS (filtro P16 Aviofiber)	'13→'14	R127STK	* 300,00
1199	PANIGALE S ABS (filtro P16 Carbon Fiber)	'13→'14	R127SBK	* 300,00
1199	PANIGALE S TRICOLORE	'12→'14	PM127S	86,00
1199	PANIGALE S TRICOLORE (filtro P16)	'12→'14	PM127S16	* 172,00
1199	PANIGALE S TRICOLORE (filtro P037)	'13→'14	PM127S-WP	* 192,00
1199	PANIGALE S TRICOLORE (filtro PF1-85)	'12→'14	PM127SF1-85	* 199,00
1199	PANIGALE S TRICOLORE (filtro P16 Aviofiber)	'12→'14	R127STK	* 300,00
1199	PANIGALE S TRICOLORE (filtro P16 Carbon Fiber)	'12→'14	R127SBK	* 300,00
1199	SUPERLEGGERA	'14	PM127S	86,00

FILTRI ARIA - AIR FILTERS

CC	Modello Model	Anno Years	Codice Code	€
1199	SUPERLEGGERA (filtro P16)	'14	PM127S16	* 172,00
1199	SUPERLEGGERA (filtro P037)	'14	PM127S-WP	* 192,00
1199	SUPERLEGGERA (filtro PF1-85)	'14	PM127SF1-85	* 199,00
1199	SUPERLEGGERA (filtro P16 Aviofiber)	'14	R127STK	* 300,00
1199	SUPERLEGGERA (filtro P16 Carbon Fiber)	'14	R127SBK	* 300,00
1200	DIAVEL	'11→'18	CM13S	78,75
1200	DIAVEL AMG	'12	CM13S	78,75
1200	DIAVEL CARBON	'11→'18	CM13S	78,75
1200	DIAVEL CROMO	'12	CM13S	78,75
1200	DIAVEL DARK	'12→'13	CM13S	78,75
1200	DIAVEL DIESEL	'17→'18	CM13S	78,75
1200	DIAVEL STRADA	'13→'14	CM13S	78,75
1200	DIAVEL TITANIUM	'15	CM13S	78,75
1200	MONSTER	'14→'20	CM61S	71,00
1200	MONSTER (filtro PF1-85)	'14→'20	CM61SF1-85	* 199,00
1200	MONSTER (filtro P037)	'14→'20	CM61S-WP	* 142,00
1200	MONSTER 25° ANIVERSARY	'19	CM61S	71,00
1200	MONSTER 25° ANIVERSARY (filtro PF1-85)	'19	CM61SF1-85	* 199,00
1100	MONSTER 25° ANNIVERSARY (filtro P037)	'19	CM61S-WP	* 142,00
1200	MONSTER R	'16→'19	CM61S	71,00
1200	MONSTER R (filtro PF1-85)	'16→'19	CM61SF1-85	* 199,00
1200	MONSTER R (filtro P037)	'16→'19	CM61S-WP	* 142,00
1200	MONSTER S	'14→'20	CM61S	71,00
1200	MONSTER S (filtro PF1-85)	'14→'20	CM61SF1-85	* 199,00
1200	MONSTER S (filtro P037)	'14→'20	CM61S-WP	* 142,00
1200	MONSTER S STRIPE	'15→'16	CM61S	71,00
1200	MONSTER S STRIPE (filtro PF1-85)	'15→'16	CM61SF1-85	* 199,00
1200	MONSTER S STRIPE (filtro P037)	'15→'16	CM61S-WP	* 142,00
1200	MULTISTRADA	'10→'12	CM13S	78,75
1200	MULTISTRADA ABS	'10→'14	CM13S	78,75
1200	MULTISTRADA ABS	'15→'17	PM127S	86,00
1200	MULTISTRADA ABS (filtro P16)	'15→'17	PM127S16	* 172,00
1200	MULTISTRADA ABS (filtro P037)	'15→'17	PM127S-WP	* 192,00
1200	MULTISTRADA ABS (filtro PF1-85)	'15→'17	PM127SF1-85	* 199,00
1200	MULTISTRADA ENDURO	'16→'18	PM127S	86,00
1200	MULTISTRADA ENDURO (filtro P16)	'16→'18	PM127S16	* 172,00
1200	MULTISTRADA ENDURO (filtro P037)	'16→'18	PM127S-WP	* 192,00
1200	MULTISTRADA ENDURO (filtro PF1-85)	'16→'18	PM127SF1-85	* 199,00
1200	MULTISTRADA ENDURO PRO	'17→'19	PM127S	86,00
1200	MULTISTRADA ENDURO PRO (filtro P16)	'17→'19	PM127S16	* 172,00
1200	MULTISTRADA ENDURO PRO (filtro P037)	'17→'19	PM127S-WP	* 192,00
1200	MULTISTRADA ENDURO PRO (filtro PF1-85)	'17→'19	PM127SF1-85	* 199,00
1200	MULTISTRADA ENDURO TOURING	'16→'18	PM127S	86,00
1200	MULTISTRADA ENDURO TOURING (filtro P16)	'16→'18	PM127S16	* 172,00
1200	MULTISTRADA ENDURO TOURING (filtro P037)	'16→'18	PM127S-WP	* 192,00
1200	MULTISTRADA ENDURO TOURING (filtro PF1-85)	'16→'18	PM127SF1-85	* 199,00
1200	MULTISTRADA PIKES PEAK	'16→'17	PM127S	86,00
1200	MULTISTRADA PIKES PEAK (filtro P16)	'16→'17	PM127S16	* 172,00
1200	MULTISTRADA PIKES PEAK (filtro P037)	'16→'17	PM127S-WP	* 192,00
1200	MULTISTRADA PIKES PEAK (filtro PF1-85)	'16→'17	PM127SF1-85	* 199,00
1200	MULTISTRADA S	'15→'17	PM127S	86,00
1200	MULTISTRADA S (filtro P16)	'15→'17	PM127S16	* 172,00
1200	MULTISTRADA S (filtro P037)	'15→'17	PM127S-WP	* 192,00
1200	MULTISTRADA S (filtro PF1-85)	'15→'17	PM127SF1-85	* 199,00
1200	MULTISTRADA S D-AIR	'15→'17	PM127S	86,00
1200	MULTISTRADA S D-AIR (filtro P16)	'15→'17	PM127S16	* 172,00
1200	MULTISTRADA S D-AIR (filtro P037)	'15→'17	PM127S-WP	* 192,00
1200	MULTISTRADA S D-AIR (filtro PF1-85)	'15→'17	PM127SF1-85	* 199,00
1200	MULTISTRADA S GRANTURISMO	'13→'14	CM13S	78,75
1200	MULTISTRADA S PIKES PEAK	'12→'14	CM13S	78,75
1200	MULTISTRADA S SPORT	'10→'12	CM13S	78,75
1200	MULTISTRADA S TOURING	'10→'14	CM13S	78,75
1200	MULTISTRADA S TOURING D-AIR	'14	CM13S	78,75

FILTRI ARIA - AIR FILTERS

CC	Modello Model	Anno Years	Codice Code	€
1260	DIAVEL	'19→'20	PM127S	86,00
1260	DIAVEL (filtro P16)	'19→'20	PM127S16	* 172,00
1260	DIAVEL (filtro P037)	'19→'20	PM127S-WP	* 192,00
1260	DIAVEL (filtro PF1-85)	'19→'20	PM127SF1-85	* 199,00
1260	DIAVEL S	'19→'20	PM127S	86,00
1260	DIAVEL S (filtro P16)	'19→'20	PM127S16	* 172,00
1260	DIAVEL S (filtro P037)	'19→'20	PM127S-WP	* 192,00
1260	DIAVEL S (filtro PF1-85)	'19→'20	PM127SF1-85	* 199,00
1260	MULTISTRADA	'18→'20	PM127S	86,00
1260	MULTISTRADA (filtro P16)	'18→'20	PM127S16	* 172,00
1260	MULTISTRADA (filtro P037)	'18→'20	PM127S-WP	* 192,00
1260	MULTISTRADA (filtro PF1-85)	'18→'20	PM127SF1-85	* 199,00
1260	MULTISTRADA ENDURO	'19→'20	PM127S	86,00
1260	MULTISTRADA ENDURO (filtro P16)	'19→'20	PM127S16	* 172,00
1260	MULTISTRADA ENDURO (filtro P037)	'19→'20	PM127S-WP	* 192,00
1260	MULTISTRADA ENDURO (filtro PF1-85)	'19→'20	PM127SF1-85	* 199,00
1260	MULTISTRADA S	'18→'20	PM127S	86,00
1260	MULTISTRADA S (filtro P16)	'18→'20	PM127S16	* 172,00
1260	MULTISTRADA S (filtro P037)	'18→'20	PM127S-WP	* 192,00
1260	MULTISTRADA S (filtro PF1-85)	'18→'20	PM127SF1-85	* 199,00
1260	MULTISTRADA S D-AIR	'18→'20	PM127S	86,00
1260	MULTISTRADA S D-AIR (filtro P16)	'18→'20	PM127S16	* 172,00
1260	MULTISTRADA S D-AIR (filtro P037)	'18→'20	PM127S-WP	* 192,00
1260	MULTISTRADA S D-AIR (filtro PF1-85)	'18→'20	PM127SF1-85	* 199,00
1260	MULTISTRADA S GRAND TOUR	'20→	PM127S	86,00
1260	MULTISTRADA S GRAND TOUR (filtro P16)	'20→	PM127S16	* 172,00
1260	MULTISTRADA S GRAND TOUR (filtro P037)	'20→	PM127S-WP	* 192,00
1260	MULTISTRADA S GRAND TOUR (filtro PF1-85)	'20→	PM127SF1-85	* 199,00
1260	MULTISTRADA S PIKES PEAK	'18→'20	PM127S	86,00
1260	MULTISTRADA S PIKES PEAK (filtro P16)	'18→'20	PM127S16	* 172,00
1260	MULTISTRADA S PIKES PEAK (filtro P037)	'18→'20	PM127S-WP	* 192,00
1260	MULTISTRADA S PIKES PEAK (filtro PF1-85)	'18→'20	PM127SF1-85	* 199,00
1262	XDIAVEL	'16→'20	PM127S	86,00
1262	XDIAVEL (filtro P16)	'16→'20	PM127S16	* 172,00
1262	XDIAVEL (filtro P037)	'16→'20	PM127S-WP	* 192,00
1262	XDIAVEL (filtro PF1-85)	'16→'20	PM127SF1-85	* 199,00
1262	XDIAVEL S	'16→'20	PM127S	86,00
1262	XDIAVEL S (filtro P16)	'16→'20	PM127S16	* 172,00
1262	XDIAVEL S (filtro P037)	'16→'20	PM127S-WP	* 192,00
1262	XDIAVEL S (filtro PF1-85)	'16→'20	PM127SF1-85	* 199,00
1299	PANIGALE	'15→'17	PM127S	86,00
1299	PANIGALE (filtro P16)	'15→'17	PM127S16	* 172,00
1299	PANIGALE (filtro P037)	'15→'17	PM127S-WP	* 192,00
1299	PANIGALE (filtro PF1-85)	'15→'17	PM127SF1-85	* 199,00
1299	PANIGALE (filtro P16 Aviofiber)	'15→'20	R127STK	* 300,00
1299	PANIGALE (filtro P16 Carbon Fiber)	'15→'20	R127SBK	* 300,00
1299	PANIGALE R FINAL EDITION	'17→'18	PM127S	86,00
1299	PANIGALE R FINAL EDITION (filtro P16)	'17→'18	PM127S16	* 172,00
1299	PANIGALE R FINAL EDITION (filtro P037)	'17→'18	PM127S-WP	* 192,00
1299	PANIGALE R FINAL EDITION (filtro PF1-85)	'17→'18	PM127SF1-85	* 199,00
1299	PANIGALE R FINAL EDITION (filtro P16 Aviofiber)	'17→'18	R127STK	* 300,00
1299	PANIGALE R FINAL ED. (filtro P16 Carbon Fiber)	'17→'18	R127SBK	* 300,00
1299	PANIGALE S	'15→'17	PM127S	86,00
1299	PANIGALE S (filtro P16)	'15→'17	PM127S16	* 172,00
1299	PANIGALE S (filtro P037)	'15→'17	PM127S-WP	* 192,00
1299	PANIGALE S (filtro PF1-85)	'15→'17	PM127SF1-85	* 199,00
1299	PANIGALE S (filtro P16 Aviofiber)	'15→'17	R127STK	* 300,00
1299	PANIGALE S (filtro P16 Carbon Fiber)	'15→'17	R127SBK	* 300,00
1299	PANIGALE S ANNIVERSARIO	'16→'17	PM127S	86,00
1299	PANIGALE S ANNIVERSARIO (filtro P16)	'16→'17	PM127S16	* 172,00
1299	PANIGALE S ANNIVERSARIO (filtro P037)	'16→'17	PM127S-WP	* 192,00
1299	PANIGALE S ANNIVERSARIO (filtro PF1-85)	'16→'17	PM127SF1-85	* 199,00
1299	PANIGALE S ANNIVERSARIO (filtro P16 Aviofiber)	'16→'17	R127STK	* 300,00

FILTRI ARIA - AIR FILTERS

CC	Modello Model	Anno Years	Codice Code	€
1299	PANIGALE S ANN. (filtro P16 Carbon Fiber)	'16→'17	R127SBK	* 300,00
1299	SUPERLEGGERA	'17	PM127S	86,00
1299	SUPERLEGGERA (filtro P16)	'17	PM127S16	* 172,00
1299	SUPERLEGGERA (filtro P037)	'17	PM127S-WP	* 192,00
1299	SUPERLEGGERA (filtro PF1-85)	'17	PM127SF1-85	* 199,00
1299	SUPERLEGGERA (filtro P16 Aviofiber)	'17	R127STK	* 300,00
1299	SUPERLEGGERA (filtro P16 Carbon Fiber)	'17	R127SBK	* 300,00

(*) Questi articoli non hanno la solita scontistica ma un prezzo netto.

GARELLI

125	MOSQUITO	'07→'08	PM103S	* 39,00
125	TIGER	'07→'08	PM103S	* 39,00
125	XO	'09→'12	PM103S	* 39,00
150	KING	'07→'08	PM103S	* 39,00
150	MOSQUITO	'07→'08	PM103S	* 39,00
150	XO'	'09→'12	PM103S	* 39,00

(*) Questi articoli non hanno la solita scontistica ma un prezzo netto.

GILERA

500	NEXUS	'03→'10	P077S	46,00
800	GP	'08→'14	PM120S	70,00

HARLEY DAVIDSON

1200	XR X SPORTSTER	'10→'12	PM40S	57,50
------	----------------	---------	-------	-------

HONDA

125	@ NES	'00→'06	PM103S	* 39,00
125	DYLAN	'02→'04	PM103S	* 39,00
125	MSX GROM	'14→'18	PM180S	64,00
125	MSX GROM ABS	'17→'19	PM180S	64,00
125	MONKEY	'18→'19	PM179S	64,00
125	PCX ABS	'18→'20	PM178S	75,00
125	PCX ABS (filtro P037)	'18→'20	PM178S-WP	* 150,00
125	PS I (PES)	'06→'13	PM103S	* 39,00
125	SH	'00→'04	PM103S	* 39,00
125	SH i	'05→'12	PM103S	* 39,00
125	SH i (TAMBURO POSTERIORE)	'09→'12	PM103S	* 39,00
150	@ NES	'01→'06	PM103S	* 39,00
150	DYLAN	'02→'06	PM103S	* 39,00
150	FS	'16→'18	PM183S	50,00
150	FS (filtro P037)	'16→'18	PM183S-WP	* 100,00
150	PCX ABS	'18→'20	PM178S	75,00
150	PCX ABS (filtro P037)	'18→'20	PM178S-WP	* 150,00
150	PS I (PES)	'06→'11	PM103S	* 39,00
150	RS	'16→'18	PM183S	50,00
150	RS (filtro P037)	'16→'18	PM183S-WP	* 100,00
150	SH	'00→'06	PM103S	* 39,00
150	SH i	'05→'12	PM103S	* 39,00
150	SH i (TAMBURO POSTERIORE)	'09→'12	PM103S	* 39,00
150	SH i SPECIAL	'05→'08	PM103S	* 39,00
150	SH i SPORT	'05→'12	PM103S	* 39,00
150	SUPRA GTR	'16→'18	PM183S	50,00
150	SUPRA GTR (filtro P037)	'16→'18	PM183S-WP	* 100,00
150	X-ADV	'19→'20	PM178S	75,00
150	X-ADV (filtro P037)	'19→'20	PM178S-WP	* 150,00
150	WINNER	'16→'18	PM183S	50,00
150	WINNER (filtro P037)	'16→'18	PM183S-WP	* 100,00
300	FORZA (NSS)	'13→'15	PM104S	51,30
300	FORZA ABS (NSS A)	'13→'19	PM104S	51,30
300	SH i	'06→'14	PM104S	51,30
300	SH i ABS	'06→'15	PM104S	51,30
300	SH i SPECIAL	'13→'14	PM104S	51,30

FILTRI ARIA - AIR FILTERS

CC	Modello Model	Anno Years	Codice Code	€
300	SH i SPORT	'06→'10	PM104S	51,30
300	SH i SPORT ABS	'18→'19	PM104S	51,30
300	SH i SPORTY	'13→'14	PM104S	51,30
400	CB REVO	'08→'20	OM184S	50,00
400	CB REVO (filtro PF1-85)	'08→'20	OM184SF1-85	* 199,00
400	CB REVO (filtro P037)	'08→'20	OM184SF-WP	* 100,00
400	CB SUPER BOL D'OR	'08→'20	OM184S	50,00
400	CB SUPER BOL D'OR (filtro PF1-85)	'08→'20	OM184SF1-85	* 199,00
400	CB SUPER BOL D'OR (filtro P037)	'08→'20	OM184SF-WP	* 100,00
400	CB SUPER FOUR	'99→'05	OM184S	50,00
400	CB SUPER FOUR (filtro PF1-85)	'99→'05	OM184SF1-85	* 199,00
400	CB SUPER FOUR (filtro P037)	'99→'05	OM184SF-WP	* 100,00
500	CB F	'13→'16	CM136S	80,00
500	CB F ABS	'13→'17	CM136S	80,00
500	CB X	'13→'15	CM136S	80,00
500	CB X ABS	'13→'17	CM136S	80,00
500	CBF	'04→'07	CM14S	51,30
500	CBF ABS	'04→'07	CM14S	51,30
500	CBR R	'13→'15	CM136S	80,00
500	CBR R ABS	'13→'17	CM136S	80,00
600	CB F HORNET	'98→'06	CM14S	51,30
600	CB F HORNET	'07→'13	CM36S	63,00
600	CB F HORNET ABS	'00→'06	CM14S	51,30
600	CB F HORNET ABS	'07→'13	CM36S	63,00
600	CB F HORNET S	'99→'04	CM14S	51,30
600	CBF N	'04→'07	CM14S	51,30
600	CBF N	'08→'12	CM36S	63,00
600	CBF N ABS	'04→'07	CM14S	51,30
600	CBF N ABS	'08→'12	CM36S	63,00
600	CBF S	'04→'06	CM14S	51,30
600	CBF S	'07→'13	CM36S	63,00
600	CBF S ABS	'04→'06	CM14S	51,30
600	CBF S ABS	'07→'13	CM36S	63,00
600	CBR F	'11→'13	CM36S	63,00
600	CBR F ABS	'11→'11	CM36S	63,00
600	CBR F4	'99→'00	PM13S	78,20
600	CBR RR	'03→'06	PM16S	82,50
600	CBR RR	'07→'16	PM46S	82,50
600	CBR RR (filtro P16)	'07→'16	PM46S16	* 165,00
600	CBR RR (filtro PF1-85)	'07→'16	PM46SF1-85	* 199,00
600	CBR RR ABS	'09→'16	PM46S	82,50
600	CBR RR ABS (filtro P16)	'09→'16	PM46S16	* 165,00
600	CBR RR ABS (filtro PF1-85)	'09→'16	PM46SF1-85	* 199,00
650	CBR R	'19→'20	PM182S	90,00
700	CTX ABS DCT	'14→'16	PM181S	94,00
700	CTX N ABS DCT	'14→'16	PM181S	94,00
700	NC S	'12→'14	PM181S	94,00
700	NC S ABS	'12→'14	PM181S	94,00
700	NC S DCT ABS	'12→'14	PM181S	94,00
700	NC X	'12→'14	PM181S	94,00
700	NC X ABS	'12→'14	PM181S	94,00
700	NC X DCT ABS	'12→'14	PM181S	94,00
750	NC INTEGRA DTC	'14→'20	PM181S	94,00
750	NC INTEGRA DTC S	'14→'20	PM181S	94,00
700	XL V TRANSALP	'08→'13	PM113S	80,00
750	X-ADV	'17→'20	PM173S	89,00
750	NC S	'14	PM181S	94,00
750	NC S ABS	'14→'20	PM181S	94,00
750	NC S ABS (35 Kw)	'18→'20	PM181S	94,00
750	NC S DCT	'14→'15	PM181S	94,00
750	NC S DCT ABS	'16→'20	PM181S	94,00

FILTRI ARIA - AIR FILTERS

CC	Modello Model	Anno Years	Codice Code	€
750	NC S ABS DCT (35 Kw)	'18→'20	PM181S	94,00
750	NC X	'14	PM181S	94,00
750	NC X ABS	'14→'20	PM181S	94,00
750	NC X ABS (35 Kw)	'18→'20	PM181S	94,00
750	NC X ABS DCT	'14→'20	PM181S	94,00
750	NC X ABS DCT (35 Kw)	'18→'20	PM181S	94,00
750	X-ADV (filtro PF1-85)	'17→'20	PM173SF1-85	* 199,00
750	X-ADV (filtro P037)	'17→'20	PM173S-WP	* 178,00
800	VFR ABS	'02→'05	PM112S	80,00
800	VFR FI	'98→'05	PM112S	80,00
800	VFR X CROSSRUNNER	'15	PM112S	80,00
900	CB F HORNET	'02→'07	CM15S	51,30
1000	CB R	'09→'15	CM96S	78,20
1000	CBF F	'10→'15	CM96S	78,20
1000	CBR RR (2 filtri)	'04→'07	CM17S	126,17
1000	CBR RR	'08→'16	PM58S	85,50
1000	CBR RR (filtro P16)	'08→'16	PM58S16	* 171,00
1000	CBR RR (filtro PF1-85)	'08→'16	PM58SF1-85	* 199,00
1000	CBR RR	'17→'19	PM158S	86,00
1000	CBR RR (filtro PF1-85)	'17→'19	PM158SF1-85	* 199,00
1000	CBR RR ABS	'12→'16	PM58S	85,50
1000	CBR RR ABS (filtro P16)	'12→'16	PM58S16	* 171,00
1000	CBR RR ABS (filtro PF1-85)	'12→'16	PM58SF1-85	* 199,00
1000	CBR RR SP ABS	'14→'16	PM58S	85,50
1000	CBR RR SP ABS (filtro P16)	'14→'16	PM58S16	* 171,00
1000	CBR RR SP ABS (filtro PF1-85)	'14→'16	PM58SF1-85	* 199,00
1000	CBR RR SP	'17→'19	PM158S	86,00
1000	CBR RR SP (filtro PF1-85)	'17→'19	PM158SF1-85	* 199,00
1000	CBR RR SP2	'17→'19	PM158S	86,00
1000	CBR RR SP2 (filtro PF1-85)	'17→'19	PM158SF1-85	* 199,00
1000	CBR RR-R (filtro PF1-85 scocca in carbonio)	'20→	R177SF1-85	* 500,00
1000	CRF AFRICA TWIN ABS (2 filtri)	'16→'19	PM159S	145,00
1000	CRF AFRICA TWIN ABS (2 filtri) (filtro P037)	'16→'19	PM159S-WP	* 290,00
1000	CRF AFRICA TWIN ADVENTURE SPORT ABS	'18→'19	PM159S	145,00
1000	CRF AFRICA TWIN ADVENTURE SPORT ABS (2 filtri) (filtro P037)	'18→'19	PM159S-WP	* 290,00
1000	CRF AFRICA TWIN ADVENTURE SPORT DCT ABS (2 filtri)	'18→'19	PM159S	145,00
1000	CRF AFRICA TWIN ADVENTURE SPORTDCT ABS (2 filtri) (filtro P037)	'18→'19	PM159S-WP	* 290,00
1000	CRF AFRICA TWIN DCT ABS (2 filtri)	'16→'19	PM159S	145,00
1000	CRF AFRICA TWIN DCT ABS (2 filtri) (filtro P037)	'16→'19	PM159S-WP	* 290,00
1000	CRF AFRICA TWIN REPLICAB ABS (2 filtri)	'17→'18	PM159S	145,00
1000	CRF AFRICA TWIN REPLICAB ABS (2 filtri) (filtro P037)	'17→'18	PM159S-WP	* 290,00
1000	CRF AFRICA TWIN REPLICAB DCT ABS (2 filtri)	'18→'18	PM159S	145,00
1000	CRF AFRICA TWIN REPLICAB DCT ABS (2 filtri) (filtro P037)	'18	PM159S-WP	* 290,00
1000	CRF L AFRICA TWIN ABS (2 filtri)	'16→'19	PM159S	145,00
1000	CRF L AFRICA TWIN ABS (2 filtri) (filtro P037)	'16→'19	PM159S-WP	* 290,00
1000	CRF L AFRICA TWIN ADVENTURE SPORT ABS	'18→'19	PM159S	145,00
1000	CRF L AFRICA TWIN ADVENTURE SPORT ABS (2 filtri) (filtro P037)	'18→'19	PM159S-WP	* 290,00
1000	CRF L AFRICA TWIN ADVENTURE SPORT DCT ABS (2 filtri)	'18→'19	PM159S	145,00
1000	CRF L AFRICA TWIN ADVENTURE SPORTDCT ABS (2 filtri) (filtro P037)	'18→'19	PM159S-WP	* 290,00
1000	CRF L AFRICA TWIN DCT ABS (2 filtri)	'16→'19	PM159S	145,00
1000	CRF L AFRICA TWIN DCT ABS (2 filtri) (filtro P037)	'16→'19	PM159S-WP	* 290,00
1000	CRF L AFRICA TWIN REPLICAB ABS (2 filtri)	'18→	PM159S	145,00
1000	CRF L AFRICA TWIN REPLICAB ABS (2 filtri) (filtro P037)	'18→	PM159S-WP	* 290,00
1000	CRF L AFRICA TWIN REPLICAB DCT ABS (2 filtri)	'18→	PM159S	145,00

FILTRI ARIA - AIR FILTERS

CC	Modello Model	Anno Years	Codice Code	€
1000	CRF L AFRICA TWIN REPLICA DCT ABS (2 filtri) (filtro P037)	'18→	PM159S-WP	* 290,00
1100	CB ABS	'13→'15	CM101S	83,00
1100	CB EX	'14→'16	CM101S	83,00
1100	CB EX ABS	'17→'20	CM101S	83,00
1100	CB RS ABS	'17→'20	CM101S	83,00
1300	CB SUPER FOUR	'05→'09	CM101S	83,00
1300	CB N	'05→'12	CM101S	83,00
1300	CB N ABS	'05→'12	CM101S	83,00
1300	CB S	'05→'09	CM101S	83,00
1300	CB S ABS	'05→'13	CM101S	83,00

(*) Questi articoli non hanno la solita scontistica ma un prezzo netto per il rivenditore.

HUSQVARNA

250	SVARTPILEN	'20→	PM200S	76,00
250	SVARTPILEN (filtro P037)	'20→	PM200S-WP	* 152,00
250	SVARTPILEN (filtro PF1-85)	'20→	PM200SF1-85	* 199,00
401	SVARTPILEN	'18→'20	PM200S	76,00
401	SVARTPILEN (filtro P037)	'18→'20	PM200S-WP	* 152,00
401	SVARTPILEN (filtro PF1-85)	'18→'20	PM200SF1-85	* 199,00
401	VITIPILEN	'18→'20	PM200S	76,00
401	VITIPILEN (filtro P037)	'18→'20	PM200S-WP	* 152,00
401	VITIPILEN (filtro PF1-85)	'18→'20	PM200SF1-85	* 199,00
700	SUPERMOTO 701	'16→'20	PM74S	82,95
700	ENDURO 701	'16→'20	PM74S	82,95
700	SVARTPILEN 701	'18→'20	PM155S	89,00
700	SVARTPILEN 701 (filtro P037)	'18→'20	PM155S-WP	* 178,00
700	SVARTPILEN 701 (filtro PF1-85)	'18→'20	PM155SF1-85	* 199,00
700	VITIPILEN 701	'18→'20	PM155S	89,00
700	VITIPILEN 701 (filtro P037)	'18→'20	PM155S-WP	* 178,00
700	VITIPILEN 701 (filtro PF1-85)	'18→'20	PM155SF1-85	* 199,00
900	NUDA	'12→'14	PM109S	51,80
900	NUDA (filtro PF1-85)	'12→'14	PM109SF1-85	* 199,00
900	NUDA (filtro P037)	'12→'14	PM109S-WP	* 104,00
900	NUDA R	'12→'14	PM109S	51,80
900	NUDA R (filtro PF1-85)	'12→'14	PM109SF1-85	* 199,00
900	NUDA R (filtro P037)	'12→'14	PM109S-WP	* 104,00

KAWASAKI

125	J	'16→'20	PM105S	51,30
250	NINJA R	'08→'12	PM95S	75,90
250	NINJA R (filtro PF1-85)	'08→'12	PM95SF1-85	* 199,00
300	J	'14→'16	PM105S	51,30
300	J ABS	'14→'20	PM105S	51,30
300	NINJA	'12→'16	PM95S	75,90
300	NINJA (filtro PF1-85)	'12→'16	PM95SF1-85	* 199,00
300	NINJA ABS	'12→'16	PM95S	75,90
300	NINJA ABS (filtro PF1-85)	'12→'16	PM95SF1-85	* 199,00
300	Z ABS	'15→'16	PM95S	75,90
300	Z ABS (filtro PF1-85)	'15→'16	PM95SF1-85	* 199,00
300	Z NINJA ABS	'15→'16	PM95S	75,90
300	Z NINJA ABS (filtro PF1-85)	'15→'16	PM95SF1-85	* 199,00
400	KLX R	'03→'04	CM45S	64,50
400	NINJA	'18→'20	PM164S	87,00
400	NINJA (filtro PF1-85)	'18→'20	PM164SF1-85	* 199,00
400	NINJA (filtro P037)	'18→'20	PM164S-WP	* 194,00
400	Z ABS	'19	PM164S	87,00
400	Z ABS (filtro PF1-85)	'19	PM164SF1-85	* 199,00
400	Z ABS (filtro P037)	'19	PM164S-WP	* 194,00
600	ZX-6R	'98→'01	PM18S	84,35
600	ZX-6R	'07→'08	PM48S	80,35
600	ZX-6R	'09→'16	PM92S	80,35

FILTRI ARIA - AIR FILTERS

CC	Modello Model	Anno Years	Codice Code	€
600	ZX-6R (filtro PF1-85)	'09→'16	PM92SF1-85	* 199,00
600	ZX-6RR	'05→'07	PM20S	80,35
600	ZZR	'05→'07	PM18S	84,35
636	ZX-6R	'02	PM18S	84,35
636	ZX-6R	'05→'06	PM20S	80,35
636	ZX-6R	'13→'15	PM92S	80,35
636	ZX-6R (filtro PF1-85)	'13→'15	PM92SF1-85	* 199,00
636	ZX-6R ABS	'13→'20	PM92S	80,35
636	ZX-6R ABS (filtro PF1-85)	'13→'20	PM92SF1-85	* 199,00
636	ZX-6R KRT EDITION ABS	'16→'20	PM92S	80,35
636	ZX-6R ZX-6R KRT EDITION ABS (filtro PF1-85)	'16→'20	PM92SF1-85	* 199,00
636	ZX-6R 30TH ANNIVERSARY EDITION	'15→'15	PM92S	80,35
636	ZX-6R 30TH ANNIVERSARY EDITION (filtro PF1-85)	'15	PM92SF1-85	* 199,00
636	ZX-6R 30TH ANNIVERSARY EDITION ABS	'15	PM92S	80,35
636	ZX-6R 30TH ANNIVERSARY EDITION ABS (filtro PF1-85)	'15	PM92SF1-85	* 199,00
650	VULCAN S	'15→'17	PM163S	84,00
650	VULCAN S (filtro PF1-85)	'15→'17	PM163SF1-85	* 199,00
650	VULCAN S (filtro P037)	'15→'17	PM163S-WP	* 175,00
650	VULCAN S ABS	'15→'20	PM163S	84,00
650	VULCAN S ABS (filtro PF1-85)	'15→'20	PM163SF1-85	* 199,00
650	VULCAN S ABS (filtro P037)	'15→'20	PM163S-WP	* 175,00
650	VULCAN S CAFE ABS	'17→'20	PM163S	84,00
650	VULCAN S CAFE ABS (filtro PF1-85)	'17→'20	PM163SF1-85	* 199,00
650	VULCAN S CAFE ABS (filtro P037)	'17→'20	PM163S-WP	* 175,00
650	KLE VERSYS	'15→'16	PM163S	84,00
650	KLE VERSYS (filtro PF1-85)	'15→'16	PM163SF1-85	* 199,00
650	KLE VERSYS (filtro P037)	'15→'16	PM163S-WP	* 175,00
650	KLE VERSYS ABS	'15→'20	PM163S	84,00
650	KLE VERSYS ABS (filtro PF1-85)	'15→'20	PM163SF1-85	* 199,00
650	KLE VERSYS ABS (filtro P037)	'15→'20	PM163S-WP	* 175,00
650	KLE VERSYS ABS TOURER	'17→'20	PM163S	84,00
650	KLE VERSYS ABS TOURER (filtro PF1-85)	'17→'20	PM163SF1-85	* 199,00
650	KLE VERSYS ABS TOURER (filtro P037)	'17→'20	PM163S-WP	* 175,00
650	NINJA	'17→'20	PM163S	84,00
650	NINJA (filtro PF1-85)	'17→'20	PM163SF1-85	* 199,00
650	NINJA (filtro P037)	'17→'20	PM163S-WP	* 175,00
650	NINJA TOURER ABS	'20→	PM163S	84,00
650	NINJA TOURER ABS (filtro PF1-85)	'20→	PM163SF1-85	* 199,00
650	NINJA TOURER ABS (filtro P037)	'20→	PM163S-WP	* 175,00
650	Z ABS	'17→'20	PM163S	84,00
650	Z ABS (filtro PF1-85)	'17→'20	PM163SF1-85	* 199,00
650	Z ABS (filtro P037)	'17→'20	PM163S-WP	* 175,00
750	Z	'04→'13	OM33S	71,50
750	Z ABS	'07→'13	OM33S	71,50
750	Z R	'11→'12	OM33S	71,50
750	Z R ABS	'11→'12	OM33S	71,50
750	Z R BLACK EDITION	'12	OM33S	71,50
750	Z S	'05→'07	OM33S	71,50
800	Z	'13→'16	OM33S	71,50
800	Z ABS	'13→'16	OM33S	71,50
800	Z E	'13→'16	OM33S	71,50
800	Z E ABS	'13→'16	OM33S	71,50
800	Z E SPECIAL EDITION	'16	OM33S	71,50
800	Z E SPECIAL EDITION ABS	'16	OM33S	71,50
900	Z ABS	'17→'20	PM165S	87,50
900	Z ABS (filtro PF1-85)	'17→'20	PM165SF1-85	* 199,00
900	Z ABS (filtro P037)	'17→'20	PM165S-WP	* 175,00
900	Z RS	'18→'20	PM166S	90,00
900	Z RS (filtro PF1-85)	'18→'20	PM166SF1-85	* 199,00
900	Z RS (filtro P037)	'18→'20	PM166S-WP	* 180,00
900	Z RS CAFE	'18→'20	PM166S	90,00

FILTRI ARIA - AIR FILTERS

CC	Modello Model	Anno Years	Codice Code	€
900	Z RS CAFE (filtro PF1-85)	'18→'20	PM166SF1-85	* 199,00
900	Z RS CAFE (filtro P037)	'18→'20	PM166S-WP	* 180,00
900	ZX-9R	'98→'04	PM21S	84,35
1000	H2 NINJA	'15→'18	PM153S	90,00
1000	H2 NINJA (filtro P16)	'15→'18	PM153S16	* 180,00
1000	H2 NINJA (filtro PF1-85)	'15→'18	PM153SF1-85	* 199,00
1000	H2 NINJA CARBON	'17→'18	PM153S	90,00
1000	H2 NINJA CARBON (filtro P16)	'17→'18	PM153S16	* 180,00
1000	H2 NINJA CARBON (filtro PF1-85)	'17→'18	PM153SF1-85	* 199,00
1000	KLZ	'04→'05	PM114S	77,00
1000	KLZ VERSYS	'12→'20	PM111S	75,00
1000	KLZ VERSYS SE	'19→'20	PM111S	75,00
1000	NINJA SX	'20→	PM111S	75,00
1000	Z	'03→'09	OM33S	71,50
1000	Z	'10→'13	PM111S	75,00
1000	Z ABS	'07→'09	OM33S	71,50
1000	Z ABS	'10→'20	PM111S	75,00
1000	Z H2	'20→	PM197S	95,00
1000	Z H2 (filtro P037)	'20→	PM197S-WP	* 190,00
1000	Z H2 (filtro PF1-85)	'20→	PM197SF1-85	* 199,00
1000	Z R	'17→'20	PM111S	75,00
1000	Z SX	'11→'13	PM111S	75,00
1000	Z SX ABS	'11→'20	PM111S	75,00
1000	ZX-10R	'04→'07	PM22S	87,40
1000	ZX-10R	'08→'10	PM47S	80,35
1000	ZX-10R (filtro PF1-85)	'08→'10	PM47SF1-85	* 199,00
1000	ZX-10R	'11→'15	PM110S	85,00
1000	ZX-10R (filtro PF1-85)	'11→'15	PM110SF1-85	* 199,00
1000	ZX-10R (filtro P16)	'11→'15	PM110S16	* 170,00
1000	ZX-10R 30TH ANNIVERSARY EDITION	'15	PM110S	85,00
1000	ZX-10R 30TH ANNIVERSARY EDITION (filtro PF1-85)	'15	PM110SF1-85	* 199,00
1000	ZX-10R 30TH ANNIVERSARY EDITION (filtro P16)	'15	PM110S16	* 170,00
1000	ZX-10R ABS	'11→'15	PM110S	85,00
1000	ZX-10R ABS (filtro PF1-85)	'11→'15	PM110SF1-85	* 199,00
1000	ZX-10R ABS (filtro P16)	'11→'15	PM110S16	* 170,00
1000	ZX-10R ABS 30TH ANNIVERSARY EDITION	'15	PM110S	85,00
1000	ZX-10R ABS 30TH ANNIVERSARY EDITION (filtro PF1-85)	'15	PM110SF1-85	* 199,00
1000	ZX-10R ABS 30TH ANNIVERSARY EDITION (filtro P16)	'15	PM110S16	* 170,00
1000	ZX-10R ABS	'16→'20	PM154S	90,00
1000	ZX-10R ABS (filtro P16)	'16→'20	PM154S16	* 180,00
1000	ZX-10R ABS (filtro PF1-85)	'16→'20	PM154SF1-85	* 199,00
1000	ZX-10R ABS KRT REPLICA	'16→'18	PM154S	90,00
1000	ZX-10R ABS KRT REPLICA (filtro P16)	'16→'18	PM154S16	* 180,00
1000	ZX-10R ABS KRT REPLICA (filtro PF1-85)	'16→'18	PM154SF1-85	* 199,00
1000	ZX-10R ABS SE	'18→'20	PM154S	90,00
1000	ZX-10R ABS SE (filtro P16)	'18→'20	PM154S16	* 180,00
1000	ZX-10R ABS SE (filtro PF1-85)	'18→'20	PM154SF1-85	* 199,00
1000	ZX-10R ABS WINTER EDITION	'16	PM154S	90,00
1000	ZX-10R ABS WINTER EDITION (filtro P16)	'16	PM154S16	* 180,00
1000	ZX-10R ABS WINTER EDITION (filtro PF1-85)	'16	PM154SF1-85	* 199,00
1000	ZX-10RR ABS	'17→'20	PM154S	90,00
1000	ZX-10RR ABS (filtro P16)	'17→'20	PM154S16	* 180,00
1000	ZX-10RR ABS (filtro PF1-85)	'17→'20	PM154SF1-85	* 199,00
1400	GTR	'08→'20	PM62S	80,35
1400	ZZR	'06→'08	PM62S	80,35
1400	ZZR ABS	'08→'11	PM62S	80,35
1400	ZZR ABS	'12→'20	PM161S	90,00

FILTRI ARIA - AIR FILTERS

CC	Modello Model	Anno Years	Codice Code	€
1400	ZZR ABS (filtro PF1-85)	'12→'20	PM161SF1-85	* 199,00
1400	ZZR PERFORMANCE SPORT ABS	'16→'20	PM161S	90,00
1400	ZZR PERFORMANCE SPORT ABS (filtro PF1-85)	'16→'20	PM161SF1-85	* 199,00

(*) Questi articoli non hanno la solita scontistica ma un prezzo netto per il rivenditore.

KTM

125	DUKE	'11→'14	PM145S	60,00
125	DUKE ABS	'13→'16	PM145S	60,00
125	DUKE	'17→'20	PM200S	76,00
125	DUKE (filtro P037)	'17→'20	PM200S-WP	* 152,00
125	DUKE (filtro PF1-85)	'17→'20	PM200SF1-85	* 199,00
125	RC	'14→'20	PM145S	60,00
200	DUKE	'12→'14	PM145S	60,00
200	DUKE ABS	'13→'19	PM145S	60,00
200	DUKE	'20→	PM200S	76,00
200	DUKE (filtro P037)	'20→	PM200S-WP	* 152,00
200	DUKE (filtro PF1-85)	'20→	PM200SF1-85	* 199,00
200	RC	'14→'19	PM145S	60,00
250	ADVENTURE	'20→	PM200S	76,00
250	ADVENTURE (filtro P037)	'20→	PM200S-WP	* 152,00
250	ADVENTURE (filtro PF1-85)	'20→	PM200SF1-85	* 199,00
250	DUKE	'15→'16	PM145S	60,00
250	DUKE	'17→'20	PM200S	76,00
250	DUKE (filtro P037)	'17→'20	PM200S-WP	* 152,00
250	DUKE (filtro PF1-85)	'17→'20	PM200SF1-85	* 199,00
200	RC	'15→'17	PM145S	60,00
390	ADVENTURE	'20→	PM200S	76,00
390	ADVENTURE (filtro P037)	'20→	PM200S-WP	* 152,00
390	ADVENTURE (filtro PF1-85)	'20→	PM200SF1-85	* 199,00
390	DUKE ABS	'13→'16	PM145S	60,00
390	DUKE	'17→'20	PM200S	76,00
390	DUKE (filtro P037)	'17→'20	PM200S-WP	* 152,00
390	DUKE (filtro PF1-85)	'17→'20	PM200SF1-85	* 199,00
390	RC ABS	'14→'20	PM145S	60,00
390	RC R	'18	PM145S	60,00
690	DUKE	'08→'12	PM73S	78,50
690	DUKE ABS	'12→'19	PM73S	78,50
690	DUKE R	'10→'12	PM73S	78,50
690	DUKE R ABS	'10→'18	PM73S	78,50
690	ENDURO	'08→'10	PM74S	82,95
690	ENDURO R	'09→'13	PM74S	82,95
690	ENDURO R ABS	'14→'19	PM74S	82,95
690	SMC	'08→'11	PM74S	82,95
690	SMC R	'12→'13	PM74S	82,95
690	SMC R ABS	'14→'20	PM74S	82,95
690	SUPERMOTO	'07→'10	PM73S	78,50
690	SUPERMOTO LIMITED EDITION	'09	PM73S	78,50
690	SUPERMOTO R	'08→'10	PM73S	78,50
790	DUKE ABS	'18→'20	PM175S	86,00
790	DUKE ABS (filtro P037)	'18→'20	PM175S-WP	* 172,00
790	DUKE ABS (filtro PF1-85)	'18→'20	PM175SF1-85	* 199,00
790	DUKE L ABS	'18→'20	PM175S	86,00
790	DUKE L ABS (filtro P037)	'18→'20	PM175S-WP	* 172,00
790	DUKE L ABS (filtro PF1-85)	'18→'20	PM175SF1-85	* 199,00
790	DUKE R	'20→	PM175S	86,00
790	DUKE R (filtro P037)	'20→	PM175S-WP	* 172,00
790	DUKE R (filtro PF1-85)	'20→	PM175SF1-85	* 199,00
790	ADVENTURE	'19→'20	PM155S	89,00
790	ADVENTURE (filtro PF1-85)	'19→'20	PM155SF1-85	* 199,00

FILTRI ARIA - AIR FILTERS

CC	Modello Model	Anno Years	Codice Code	€
790	ADVENTURE (filtro P037)	'19→'20	PM155S-WP	* 178,00
790	ADVENTURE R	'19→'20	PM155S	89,00
790	ADVENTURE R (filtro PF1-85)	'19→'20	PM155SF1-85	* 199,00
790	ADVENTURE R (filtro P037)	'19→'20	PM155S-WP	* 178,00
790	ADVENTURE R RALLY	'20→	PM155S	89,00
790	ADVENTURE R RALLY (filtro PF1-85)	'20→	PM155SF1-85	* 199,00
790	ADVENTURE R RALLY (filtro P037)	'20→	PM155S-WP	* 178,00
990	ADVENTURE ABS	'06→'12	PM75S	72,30
990	ADVENTURE DAKAR EDITION ABS	'11→'11	PM75S	72,30
990	ADVENTURE LIMITED EDITION ABS	'10	PM75S	72,30
990	ADVENTURE R	'09→'12	PM75S	72,30
990	ADVENTURE S	'06→'08	PM75S	72,30
990	SUPER DUKE	'05→'11	PM75S	72,30
990	SUPER DUKE R	'07→'13	PM75S	72,30
990	SUPERMOTO	'08→'10	PM75S	72,30
990	SUPERMOTO R	'09→'12	PM75S	72,30
990	SUPERMOTO R ABS	'12→'13	PM75S	72,30
990	SUPERMOTO T	'09→'10	PM75S	72,30
990	SUPERMOTO T ABS	'11→'13	PM75S	72,30
1050	ADVENTURE ABS	'15→'16	PM155S	89,00
1050	ADVENTURE ABS (filtro PF1-85)	'15→'16	PM155SF1-85	* 199,00
1050	ADVENTURE ABS (filtro P037)	'15→'16	PM155S-WP	* 178,00
1090	ADVENTURE	'17→'19	PM155S	89,00
1090	ADVENTURE (filtro PF1-85)	'17→'19	PM155SF1-85	* 199,00
1090	ADVENTURE (filtro P037)	'17→'19	PM155S-WP	* 178,00
1090	ADVENTURE R	'17→'19	PM155S	89,00
1090	ADVENTURE R (filtro PF1-85)	'17→'19	PM155SF1-85	* 199,00
1090	ADVENTURE R (filtro P037)	'17→'19	PM155S-WP	* 178,00
1190	ADVENTURE ABS	'13→'16	PM155S	89,00
1190	ADVENTURE ABS (filtro PF1-85)	'13→'16	PM155SF1-85	* 199,00
1190	ADVENTURE ABS (filtro P037)	'13→'16	PM155S-WP	* 178,00
1190	ADVENTURE R ABS	'13→'16	PM155S	89,00
1190	ADVENTURE R ABS (filtro PF1-85)	'13→'16	PM155SF1-85	* 199,00
1190	ADVENTURE R ABS (filtro P037)	'13→'16	PM155S-WP	* 178,00
1190	RC8	'08→'11	PM76S	81,00
1190	RC8 R	'09→'16	PM76S	81,00
1190	RC8 R TRACK	'11→'13	PM76S	81,00
1290	SUPER ADVENTURE	'15→'17	PM155S	89,00
1290	SUPER ADVENTURE (filtro PF1-85)	'15→'17	PM155SF1-85	* 199,00
1290	SUPER ADVENTURE (filtro P037)	'15→'17	PM155S-WP	* 178,00
1290	SUPER ADVENTURE R	'17→'20	PM155S	89,00
1290	SUPER ADVENTURE R (filtro PF1-85)	'17→'20	PM155SF1-85	* 199,00
1290	SUPER ADVENTURE R (filtro P037)	'17→'20	PM155S-WP	* 178,00
1290	SUPER ADVENTURE S	'17→'20	PM155S	89,00
1290	SUPER ADVENTURE S (filtro PF1-85)	'17→'20	PM155SF1-85	* 199,00
1290	SUPER ADVENTURE S (filtro P037)	'17→'20	PM155S-WP	* 178,00
1290	SUPER ADVENTURE T	'17→'17	PM155S	89,00
1290	SUPER ADVENTURE T (filtro PF1-85)	'17	PM155SF1-85	* 199,00
1290	SUPER ADVENTURE T (filtro P037)	'17	PM155S-WP	* 178,00
1290	SUPER DUKE GT	'16→'20	PM155S	89,00
1290	SUPER DUKE GT (filtro PF1-85)	'16→'20	PM155SF1-85	* 199,00
1290	SUPER DUKE GT (filtro P037)	'16→'20	PM155S-WP	* 178,00
1290	SUPER DUKE R	'14→'19	PM155S	89,00
1290	SUPER DUKE R (filtro PF1-85)	'14→'19	PM155SF1-85	* 199,00
1290	SUPER DUKE R (filtro P037)	'14→'19	PM155S-WP	* 178,00
1290	SUPER DUKE R	'20→	PM190S	90,00
1290	SUPER DUKE R (filtro PF1-85)	'20→	PM190SF1-85	* 199,00
1290	SUPER DUKE R (filtro P037)	'20→	PM190S-WP	* 180,00
1290	SUPER DUKE R SE	'16→'17	PM155S	89,00
1290	SUPER DUKE R SE (filtro PF1-85)	'16→'17	PM155SF1-85	* 199,00
1290	SUPER DUKE R SE (filtro P037)	'16→'17	PM155S-WP	* 178,00

(*) Questi articoli non hanno la solita scontistica ma un prezzo netto per il rivenditore.

FILTRI ARIA - AIR FILTERS

CC	Modello Model	Anno Years	Codice Code	€
KYMCO				
125	DOWNTOWN I ABS	'17	PM105S	51,30
125	X-TOWN I ABS	'16→'19	PM105S	51,30
200	DOWNTOWN I	'10→'15	PM105S	51,30
300	DOWNTOWN I	'09→'13	PM105S	51,30
300	DOWNTOWN I ABS	'10→'16	PM105S	51,30
350	DOWNTOWN I	'15→'16	PM105S	51,30
500	XCITING	'05	PM37S	50,50
500	XCITING I	'06→'08	PM37S	50,50
500	XCITING I EVO ABS	'13	PM37S	50,50
500	XCITING I R	'07→'16	PM37S	50,50
MOTO GUZZI				
650	GT	'88→'89	PM120S	70,00
650	NTX	'86→'90	PM120S	70,00
650	V 65 CUSTOM	'82→'86	PM120S	70,00
650	V 65 FLORIDA	'86→'92	PM120S	70,00
650	V 65 POLIZIA	'88→'95	PM120S	70,00
750	BREVA IE	'03→'11	PM03S	70,00
750	NEVADA	'91→'97	PM120S	70,00
750	AQUILA NERA	'09→'10	PM03S	70,00
750	AQUILA NERA	'11→'16	PM138S	68,00
750	NEVADA CLASSIC	'04→'10	PM03S	70,00
750	NEVADA CLASSIC	'11→'15	PM138S	68,00
750	NEVADA CLUB	'98→'06	PM120S	70,00
750	NEVADA S	'10	PM03S	70,00
750	NEVADA S ANNIVERSARIO	'12	PM138S	68,00
750	POLIZIA-PA 1A SERIE <LX15449	'92→'94	PM120S	70,00
750	POLIZIA-PA 2A SERIE LX15450>	'95→'02	PM120S	70,00
750	SP	'90→'92	PM120S	70,00
750	STRADA	'93→'95	PM120S	70,00
750	TARGA	'89→'92	PM120S	70,00
750	V7 CAFE' CLASSIC	'09→'12	PM03S	70,00
750	V7 CLASSIC	'08→'12	PM03S	70,00
750	V7 RACER	'10→'11	PM03S	70,00
750	V7 RACER	'12→'14	PM138S	68,00
750	V7 SPECIAL	'12→'14	PM138S	68,00
750	V7 STONE	'12→'14	PM138S	68,00
750	V7 II RACER ABS	'15→'17	PM138S	68,00
750	V7 II SPECIAL ABS	'15→'17	PM138S	68,00
750	V7 II STONE ABS	'15→'17	PM138S	68,00
750	V7 II STORNELLO ABS	'16→'17	PM138S	68,00
750	V7 III ANNIVERSARIO ABS	'17→'18	PM138S	68,00
750	V7 III CARBON	'18→'19	PM138S	68,00
750	V7 III LIMITED	'18	PM138S	68,00
750	V7 III MILANO	'18→'19	PM138S	68,00
750	V7 III RACER ABS	'17→'19	PM138S	68,00
750	V7 III RACER ANNIVERSARY ABS	'20	PM138S	68,00
750	V7 III ROUGH	'18→'20	PM138S	68,00
750	V7 III SPECIAL ABS	'17→'20	PM138S	68,00
750	V7 III STONE ABS	'17→'20	PM138S	68,00
750	V75	'92→'01	PM120S	70,00
850	BREVA	'06→'11	CM02S	69,80
850	GRISO	'06→'11	PM01S	71,50
850	LE MANS III	'81→'84	PM120S	70,00
850	T5 CIVILE III SERIE	'84→'87	PM120S	70,00
850	T5 POLIZIA-CC VECCHIO TIPO	'85→'89	PM120S	70,00
850	NORGE T-GTL	'07→'12	CM02S	69,80
850	V85 TT	'19→'20	PM01S	71,50
850	V85 TT TRAVEL PACK ABS	'20→	PM01S	71,50

FILTRI ARIA - AIR FILTERS

CC	Modello Model	Anno Years	Codice Code	€
850	V9 BOBBER	'16→'20	PM138S	68,00
850	V9 BOBBER SPORT	'19	PM138S	68,00
850	V9 ROAMER	'16→'19	PM138S	68,00
940	BELLAGIO	'07→'14	P031S	60,00
940	BELLAGIO - AQUILA NERA	'07→'14	P031S	60,00
1000	CALIFORNIA II	'81→'87	PM120S	70,00
1000	DAYTONA	'92→'95	P031S	60,00
1000	DAYTONA RACING	'96	P031S	60,00
1000	DAYTONA RS	'96→'01	P031S	60,00
1000	GT	'87→'91	PM120S	70,00
1000	QUOTA	'92→'97	P031S	60,00
1000	SP II	'84→'88	PM120S	70,00
1000	V10 CENTAURO	'97→'99	P031S	60,00
1100	BREVA	'05→'09	CM02S	69,80
1100	BREVA ABS	'05→'07	CM02S	69,80
1100	CALIFORNIA	'94→'97	P031S	60,00
1100	CALIFORNIA ALUMINIUM	'03→'05	P031S	60,00
1100	CALIFORNIA AQUILA NERA	'09→'11	P031S	60,00
1100	CALIFORNIA CLASSIC	'06→'12	P031S	60,00
1100	CALIFORNIA EV	'97→'05	P031S	60,00
1100	CALIFORNIA EV TOURING	'03→'05	P031S	60,00
1100	CALIFORNIA JACKAL	'99→'02	P031S	60,00
1100	CALIFORNIA METAL	'02→'03	P031S	60,00
1100	CALIFORNIA SPECIAL	'98→'02	P031S	60,00
1100	CALIFORNIA SPECIAL SPORT	'01→'02	P031S	60,00
1100	CALIFORNIA STONE	'01→'05	P031S	60,00
1100	CALIFORNIA TITANIUM	'03→'05	P031S	60,00
1100	CALIFORNIA TOURING	'06→'12	P031S	60,00
1100	CALIFORNIA VINTAGE	'06→'13	P031S	60,00
1100	GRISO	'05→'08	PM01S	71,50
1100	QUOTA ES	'99→'02	P031S	60,00
1100	SPORT	'94→'96	P031S	60,00
1100	SPORT IE	'96→'99	P031S	60,00
1100	SPORT CORSA	'98→'99	P031S	60,00
1100	V11 COPPA ITALIA	'03→'05	P031S	60,00
1100	V11 CAFE SPORT	'03→'05	P031S	60,00
1100	V11 LE MANS	'01→'05	P031S	60,00
1100	V11 LE MANS NERO CORSA	'03→'05	P031S	60,00
1100	V11 LE MANS ROSSO CORSA	'03→'05	P031S	60,00
1100	V11 SCURA R	'02	P031S	60,00
1100	V11 SPORT	'99→'02	P031S	60,00
1100	V11 SPORT BALLABIO	'03→'05	P031S	60,00
1100	V11 SPORT NAKED	'02→'05	P031S	60,00
1100	V11 SPORT SCURA	'02→'03	P031S	60,00
1200	BREVA	'08→'11	CM02S	69,80
1200	BREVA ABS	'08→'11	CM02S	69,80
1200	GRISO 8V	'07→'13	PM01S	71,50
1200	GRISO 8V SPECIAL EDITION	'09→'16	PM01S	71,50
1200	MGS-01 CORSA	'07→'11	CM02S	69,80
1200	NORGE ABS	'06→'10	CM02S	69,80
1200	NORGE GT 8V	'10→'16	CM02S	69,80
1200	SPORT	'06→'07	CM02S	69,80
1200	SPORT 4V	'08→'13	CM02S	69,80
1200	SPORT 4V ABS	'08→'13	CM02S	69,80
1200	STELVIO	'08→'11	PM01S	71,50
1200	STELVIO 8V	'11→'15	PM01S	71,50
1200	STELVIO NTX	'09→'10	PM01S	71,50
1200	STELVIO NTX 8V	'11→'16	PM01S	71,50
1400	AUDACE	'15→'19	PM01S	71,50
1400	AUDACE CARBON	'17→'19	PM01S	71,50
1400	CALIFORNIA CORAZZIERI	'18	PM01S	71,50
1400	CALIFORNIA CUSTOM ABS	'12→'16	PM01S	71,50

FILTRI ARIA - AIR FILTERS

CC	Modello Model	Anno Years	Codice Code	€
1400	CALIFORNIA TOURING	'12→'19	PM01S	71,50
1400	CALIFORNIA TOURING ABS S.E.	'15→'16	PM01S	71,50
1400	ELDORADO	'15→'19	PM01S	71,50
1400	MGX-21 FLYING FORTRESS	'16→'19	PM01S	71,50

MOTO MORINI

1200	CORSARO TI22	'18→'19	CM170S	90,00
1200	CORSARO TI22 (filtro P037)	'18→'19	CM170S-WP	* 180,00
1200	CORSARO ZT	'20	CM170S	90,00
1200	CORSARO ZT (filtro P037)	'20	CM170S-WP	* 180,00
1200	CORSARO ZZ	'18→'20	CM170S	90,00
1200	CORSARO ZZ (filtro P037)	'18→'20	CM170S-WP	* 180,00
1200	GRANPASSO	'10→'19	CM170S	90,00
1200	GRANPASSO (filtro P037)	'10→'19	CM170S-WP	* 180,00
1200	GRANPASSO R	'16→'20	CM170S	90,00
1200	GRANPASSO R (filtro P037)	'16→'20	CM170S-WP	* 180,00
1200	MILANO	'18→'20	CM170S	90,00
1200	MILANO (filtro P037)	'18→'20	CM170S-WP	* 180,00
1200	SCRAMBLER	'18→'19	CM170S	90,00
1200	SCRAMBLER (filtro P037)	'18→'19	CM170S-WP	* 180,00
1200	SCRAMBLER SUPER	'20→	CM170S	90,00
1200	SCRAMBLER SUPER (filtro P037)	'20→	CM170S-WP	* 180,00

(*) Questi articoli non hanno la solita scontistica ma un prezzo netto per il rivenditore.

MV AGUSTA

675	BRUTALE	'13→'17	CM135S	78,00
675	BRUTALE (filtro P16)	'13→'17	CM135S16	* 156,00
675	BRUTALE (filtro PF1-85)	'13→'17	CM135SF1-85	* 199,00
675	F3	'11→'20	CM135S	78,00
675	F3 (filtro P16)	'11→'20	CM135S16	* 156,00
675	F3 (filtro PF1-85)	'11→'20	CM135SF1-85	* 199,00
675	AGUSTA F3 (filtro P08 scocca in carbonio)	'11→'20	R135S	* 320,00
675	AGUSTA F3 (filtro P 037 scocca in carbonio)	'11→'20	R135S-WP	* 390,00
675	AGUSTA F3 (filtro PF1-85 scocca in carbonio)	'11→'20	R135SF1-85	* 450,00
675	F3 ORO	'12→'13	CM135S	78,00
675	F3 ORO (filtro P16)	'12→'13	CM135S16	* 156,00
675	F3 ORO (filtro PF1-85)	'12→'13	CM135SF1-85	* 199,00
675	F3 RC	'15→'19	CM135S	78,00
675	F3 RC (filtro P16)	'15→'19	CM135S16	* 156,00
675	F3 RC (filtro PF1-85)	'15→'19	CM135SF1-85	* 199,00
800	BRUTALE	'13→'18	CM135S	78,00
800	BRUTALE (filtro P16)	'13→'18	CM135S16	* 156,00
800	BRUTALE (filtro PF1-85)	'13→'18	CM135SF1-85	* 199,00
800	BRUTALE RC	'18→'19	CM135S	78,00
800	BRUTALE RC (filtro P16)	'18→'19	CM135S16	* 156,00
800	BRUTALE RC (filtro PF1-85)	'18→'19	CM135SF1-85	* 199,00
800	BRUTALE ROSSO	'20→	CM135S	78,00
800	BRUTALE ROSSO (filtro P16)	'20→	CM135S16	* 156,00
800	BRUTALE ROSSO (filtro PF1-85)	'20→	CM135SF1-85	* 199,00
800	BRUTALE RR	'15→'20	CM135S	78,00
800	BRUTALE RR (filtro P16)	'15→'20	CM135S16	* 156,00
800	BRUTALE RR (filtro PF1-85)	'15→'20	CM135SF1-85	* 199,00
800	BRUTALE RR PIRELLI	'18→'19	CM135S	78,00
800	BRUTALE RR PIRELLI (filtro P16)	'18→'19	CM135S16	* 156,00
800	BRUTALE RR PIRELLI (filtro PF1-85)	'18→'19	CM135SF1-85	* 199,00
800	DRAGSTER	'14→'16	CM135S	78,00
800	DRAGSTER (filtro P16)	'14→'16	CM135S16	* 156,00
800	DRAGSTER (filtro PF1-85)	'14→'16	CM135SF1-85	* 199,00
800	DRAGSTER RC	'17→'20	CM135S	78,00
800	DRAGSTER RC (filtro P16)	'17→'20	CM135S16	* 156,00
800	DRAGSTER RC (filtro PF1-85)	'17→'20	CM135SF1-85	* 199,00
800	DRAGSTER ROSSO	'20→	CM135S	78,00

FILTRI ARIA - AIR FILTERS

CC	Modello Model	Anno Years	Codice Code	€
800	DRAGSTER ROSSO (filtro P16)	'20→	CM135S16	* 156,00
800	DRAGSTER ROSSO (filtro PF1-85)	'20→	CM135SF1-85	* 199,00
800	DRAGSTER RR	'15→'20	CM135S	78,00
800	DRAGSTER RR (filtro P16)	'15→'20	CM135S16	* 156,00
800	DRAGSTER RR (filtro PF1-85)	'15→'20	CM135SF1-85	* 199,00
800	DRAGSTER RR LH44	'15→'16	CM135S	78,00
800	DRAGSTER RR LH44 (filtro P16)	'15→'16	CM135S16	* 156,00
800	DRAGSTER RR LH44 (filtro PF1-85)	'15→'16	CM135SF1-85	* 199,00
800	F3	'13→'20	CM135S	78,00
800	F3 (filtro P16)	'13→'20	CM135S16	* 156,00
800	F3 (filtro PF1-85)	'13→'20	CM135SF1-85	* 199,00
800	F3 AGO	'14→'15	CM135S	78,00
800	F3 AGO (filtro P16)	'14→'15	CM135S16	* 156,00
800	F3 AGO (filtro PF1-85)	'14→'15	CM135SF1-85	* 199,00
800	AGUSTA F3 (filtro P08 scocca in carbonio)	'13→'20	R135S	* 320,00
800	AGUSTA F3 (filtro P 037 scocca in carbonio)	'13→'20	R135S-WP	* 390,00
800	AGUSTA F3 (filtro PF1-85 scocca in carbonio)	'13→'20	R135SF1-85	* 450,00
800	F3 ORO	'12→'13	CM135S	78,00
800	F3 ORO (filtro P16)	'12→'13	CM135S16	* 156,00
800	F3 ORO (filtro PF1-85)	'12→'13	CM135SF1-85	* 199,00
800	F3 RC	'15→'20	CM135S	78,00
800	F3 RC (filtro P16)	'15→'20	CM135S16	* 156,00
800	F3 RC (filtro PF1-85)	'15→'20	CM135SF1-85	* 199,00
800	RIVALE	'14→'18	CM135S	78,00
800	RIVALE (filtro P16)	'14→'18	CM135S16	* 156,00
800	RIVALE (filtro PF1-85)	'14→'18	CM135SF1-85	* 199,00
800	STRADALE	'15	CM135S	78,00
800	STRADALE (filtro P16)	'15	CM135S16	* 156,00
800	STRADALE (filtro PF1-85)	'15	CM135SF1-85	* 199,00
800	TURISMO VELOCE	'15→'19	CM135S	78,00
800	TURISMO VELOCE (filtro P16)	'15→'19	CM135S16	* 156,00
800	TURISMO VELOCE (filtro PF1-85)	'15→'19	CM135SF1-85	* 199,00
800	TURISMO VELOCE LUSSO	'15→'20	CM135S	78,00
800	TURISMO VELOCE LUSSO (filtro P16)	'15→'20	CM135S16	* 156,00
800	TURISMO VELOCE LUSSO (filtro PF1-85)	'15→'20	CM135SF1-85	* 199,00
800	TURISMO VELOCE RC	'17→'20	CM135S	78,00
800	TURISMO VELOCE RC (filtro P16)	'17→'20	CM135S16	* 156,00
800	TURISMO VELOCE RC (filtro PF1-85)	'17→'20	CM135SF1-85	* 199,00
800	TURISMO VELOCE ROSSO	'20→	CM135S	78,00
800	TURISMO VELOCE ROSSO (filtro P16)	'20→	CM135S16	* 156,00
800	TURISMO VELOCE ROSSO (filtro PF1-85)	'20→	CM135SF1-85	* 199,00
1000	AGUSTA BRUTALE ORO	'20→	R189S	* 320,00
1000	AGUSTA BRUTALE ORO (filtro P08 scocca in carbonio)	'20→	R189S	* 320,00
1000	AGUSTA BRUTALE ORO (filtro P 037 scocca in carbonio)	'20→	R189S-WP	* 390,00
1000	AGUSTA BRUTALE ORO (filtro PF1-85 scocca in carbonio)	'20→	R189SF1-85	* 450,00
1000	AGUSTA BRUTALE RR (filtro P08 scocca in carbonio)	'20→	R189S	* 320,00
1000	AGUSTA BRUTALE RR (filtro P 037 scocca in carbonio)	'20→	R189S-WP	* 390,00
1000	AGUSTA BRUTALE RR (filtro PF1-85 scocca in carbonio)	'20→	R189SF1-85	* 450,00
1000	AGUSTA F4 (filtro P08 scocca in carbonio)	'13→'16	R189S	* 320,00
1000	AGUSTA F4 (filtro P 037 scocca in carbonio)	'13→'16	R189S-WP	* 390,00
1000	AGUSTA F4 (filtro PF1-85 scocca in carbonio)	'13→'16	R189SF1-85	* 450,00
1000	AGUSTA F4 R (filtro P08 scocca in carbonio)	'13→'16	R189S	* 320,00
1000	AGUSTA F4 R (filtro P 037 scocca in carbonio)	'13→'16	R189S-WP	* 390,00
1000	AGUSTA F4 R (filtro PF1-85 scocca in carbonio)	'13→'16	R189SF1-85	* 450,00
1000	AGUSTA F4 RC (filtro P08 scocca in carbonio)	'15→'18	R189S	* 320,00
1000	AGUSTA F4 RC (filtro P 037 scocca in carbonio)	'15→'18	R189S-WP	* 390,00
1000	AGUSTA F4 RC (filtro PF1-85 scocca in carbonio)	'15→'18	R189SF1-85	* 450,00
1000	AGUSTA F4 RC LH44 (filtro P08 scocca in carbonio)	'18	R189S	* 320,00

FILTRI ARIA - AIR FILTERS

CC	Modello Model	Anno Years	Codice Code	€
1000	AGUSTA F4 RC LH44 (filtro P 037 scocca in carbonio)	'18	R189S-WP	* 390,00
1000	AGUSTA F4 RC LH44 (filtro PF1-85 scocca in carbonio)	'18	R189SF1-85	* 450,00
1000	AGUSTA F4 RR (filtro P08 scocca in carbonio)	'13→'16	R189S	* 320,00
1000	AGUSTA F4 RR (filtro P 037 scocca in carbonio)	'13→'16	R189S-WP	* 390,00
1000	AGUSTA F4 RR (filtro PF1-85 scocca in carbonio)	'13→'16	R189SF1-85	* 450,00

(*) Questi articoli non hanno la solita scontistica ma un prezzo netto per il rivenditore.

PIAGGIO

125	HEXAGON GTX	'00	P077S	46,00
125	SUPERHEXAGON GTX 12"	'01→'02	P077S	46,00
180	HEXAGON GTX	'00	P077S	46,00
180	SUPERHEXAGON GTX 12"	'01→'02	P077S	46,00
500	X9	'01→'02	P077S	46,00
500	X9 EVOLUTION	'03→'07	P077S	46,00
500	X9 EVOLUTION ABS	'06→'07	P077S	46,00

POLARIS

500	SCRAMBLER (filtro P037)	'97→'12	CM172S-WP	* 150,00
500	SPORTSMAN (filtro P037)	'96→'08	CM172S-WP	* 150,00
500	SPORTSMAN EFI/HO (filtro P037)	'04→'13	CM172S-WP	* 150,00
500	SPORTSMAN X2 (filtro P037)	'06→'10	CM172S-WP	* 150,00
500	SPORTSMAN X2 EFI (filtro P037)	'07→'08	CM172S-WP	* 150,00
500	SPORTSMAN DEMAND DRIVE HO/EFI (filtro P037)	'03→'04	CM172S-WP	* 150,00
500	SPORTSMAN TOURING HO (filtro P037)	'08→'13	CM172S-WP	* 150,00
500	SPORTSMAN WORKER (filtro P037)	'98→'02	CM172S-WP	* 150,00
500	XP SPORTSMAN (filtro P037)	'09	CM172S-WP	* 150,00
570	SPORTSMAN ACE (filtro P037)	'15→'20	CM172S-WP	* 150,00
570	SPORTSMAN ACE EURO (filtro P037)	'15→'20	CM172S-WP	* 150,00
570	SPORTSMAN TOURING TRACTOR EFI EPS (filtro P037)	'14→'15	CM172S-WP	* 150,00
850	FOREST (filtro P037)	'15	CM172S-WP	* 150,00
850	SCRAMBLER (filtro P037)	'13→'18	CM172S-WP	* 150,00
850	SP SCRAMBLER TOURING (filtro P037)	'15	CM172S-WP	* 150,00
850	SPORTSMAN FOREST (filtro P037)	'12→'15	CM172S-WP	* 150,00
850	SPORTSMAN SP (filtro P037)	'15→'18	CM172S-WP	* 150,00
850	SPORTSMAN SP TOURING (filtro P037)	'15→'18	CM172S-WP	* 150,00
850	SPORTSMAN TOURING EPS (filtro P037)	'10→'14	CM172S-WP	* 150,00
850	SPORTSMAN TOURING EPS HO (filtro P037)	'13→'15	CM172S-WP	* 150,00
850	XP SCRAMBLER HO EPS (filtro P037)	'14	CM172S-WP	* 150,00
850	XP SPORTSMAN (filtro P037)	'09→'15	CM172S-WP	* 150,00
850	XP SPORTSMAN EPS (filtro P037)	'09→'14	CM172S-WP	* 150,00
850	XP SPORTSMAN TOURING EPS (filtro P037)	'12	CM172S-WP	* 150,00
1000	SCRAMBLER (filtro P037)	'14→'18	CM172S-WP	* 150,00
1000	SPORTSMAN TOURING (filtro P037)	'15→'18	CM172S-WP	* 150,00
1000	SPORTSMAN TOURING TRACTOR (filtro P037)	'16→'18	CM172S-WP	* 150,00
1000	XP SCRAMBLER (filtro P037)	'14→'20	CM172S-WP	* 150,00
1000	XP SPORTSMAN MD (filtro P037)	'15→'18	CM172S-WP	* 150,00
1000	XP SPORTSMAN TRACTOR (filtro P037)	'16→'18	CM172S-WP	* 150,00

ROYAL ENFIELD

350	BULLET	'99→'07	CM194S	58,80
350	BULLET (filtro P037)	'99→'07	CM194S-WP	* 117,60
350	BULLET (filtro PF1-85)	'99→'07	CM194SF1-85	* 199,00
350	CONTINENTAL GT EFI	'15→'18	CM195S	58,80
350	CONTINENTAL GT EFI (filtro P037)	'15→'18	CM195S-WP	* 117,60
350	CONTINENTAL GT EFI (filtro PF1-85)	'15→'18	CM195SF1-85	* 199,00
350	THUNDERBIRD	'03→'08	CM194S	58,80
350	THUNDERBIRD (filtro P037)	'03→'08	CM194S-WP	* 117,60
350	THUNDERBIRD (filtro PF1-85)	'03→'08	CM194SF1-85	* 199,00
411	HIMALAYAN	'16→'20	CM199S	64,00

FILTRI ARIA - AIR FILTERS

CC	Modello Model	Anno Years	Codice Code	€
411	HIMALAYAN (filtro P037)	'16→'20	CM199S-WP	* 128,00
411	HIMALAYAN (filtro PF1-85)	'16→'20	CM199SF1-85	* 199,00
500	BULLET	'99→'07	CM194S	58,80
500	BULLET (filtro P037)	'99→'07	CM194S-WP	* 117,60
500	BULLET (filtro PF1-85)	'99→'07	CM194SF1-85	* 199,00
500	BULLET B5 EFI	'11→'20	CM195S	58,80
500	BULLET B5 EFI (filtro P037)	'11→'20	CM195S-WP	* 117,60
500	BULLET B5 EFI (filtro PF1-85)	'11→'20	CM195SF1-85	* 199,00
500	BULLET TRIALS EFI	'19→'20	CM195S	58,80
500	BULLET TRIALS EFI (filtro P037)	'19→'20	CM195S-WP	* 117,60
500	BULLET TRIALS EFI (filtro PF1-85)	'19→'20	CM195SF1-85	* 199,00
500	CLASSIC EFI	'09→'20	CM195S	58,80
500	CLASSIC EFI (filtro P037)	'09→'20	CM195S-WP	* 117,60
500	CLASSIC EFI (filtro PF1-85)	'09→'20	CM195SF1-85	* 199,00
500	ELECTRA	'06→'08	CM194S	58,80
500	ELECTRA (filtro P037)	'06→'08	CM194S-WP	* 117,60
500	ELECTRA (filtro PF1-85)	'06→'08	CM194SF1-85	* 199,00
500	SIXTY 5	'04→'08	CM194S	58,80
500	SIXTY 5 (filtro P037)	'04→'08	CM194S-WP	* 117,60
500	SIXTY 5 (filtro PF1-85)	'04→'08	CM194SF1-85	* 199,00
650	CONTINENTAL GT	'18→'20	CM196S	58,80
650	CONTINENTAL GT (filtro P037)	'18→'20	CM196S-WP	* 117,60
650	CONTINENTAL GT (filtro PF1-85)	'18→'20	CM196SF1-85	* 199,00
650	CONTINENTAL GT (filtro P037) con flangia dedicata in acciaio	'18→'20	K196S-WP	* 132,60
650	INTERCEPTOR	'18→'20	CM196S	58,80
650	INTERCEPTOR (filtro P037)	'18→'20	CM196S-WP	* 117,60
650	INTERCEPTOR (filtro PF1-85)	'18→'20	CM196SF1-85	* 199,00
650	INTERCEPTOR (filtro P037) con flangia dedicata in acciaio	'18→'20	K196S-WP	* 132,60

(*) Questi articoli non hanno la solita scontistica ma un prezzo netto per il rivenditore.

SUZUKI

400	AN BURGMAN	'07→'15	PM106S	51,30
400	AN BURGMAN ABS	'07→'16	PM106S	51,30
400	AN BURGMAN EXECUTIVE	'09→'16	PM106S	51,30
400	AN BURGMAN EXECUTIVE ABS	'09→'17	PM106S	51,30
400	DR-Z	'00→'04	CM45S	64,50
400	DR-Z E	'00→'07	CM45S	64,50
400	DR-Z S	'00→'08	CM45S	64,50
400	DR-Z SM	'05→'09	CM45S	64,50
600	GSF BANDIT	'95→'99	PM100S	51,00
600	GSF BANDIT S	'95→'99	PM100S	51,00
600	GSX-R	'04→'05	PM24S	82,00
600	GSX-R	'06→'10	PM25S	78,50
600	GSXR	'11→'16	PM122S	84,00
650	DL V-STROM	'04→'06	PM114S	77,00
650	DL V-STROM ABS	'07→'20	PM114S	77,00
650	DL V-STROM TRAVELLER ABS	'07→'11	PM114S	77,00
650	DL V-STROM XPEDITION ABS	'11→'11	PM114S	77,00
650	DL X V-STROM	'07→'11	PM114S	77,00
650	DL X V-STROM XT ABS	'15→'20	PM114S	77,00
650	GSF N BANDIT	'05→'15	PM67S	56,00
650	GSF N BANDIT ABS	'05→'15	PM67S	56,00
650	GSF S BANDIT	'05→'15	PM67S	56,00
650	GSF S BANDIT ABS	'05→'15	PM67S	56,00
650	GSX-F	'08→'16	PM67S	56,00
650	GSX-F ABS	'08→'15	PM67S	56,00
650	SFV GLADIUS	'09→'16	PM117S	77,00
650	SFV GLADIUS ABS	'09→'16	PM117S	77,00
650	SV N	'03→'10	PM66S	79,50
650	SV ABS	'16→'20	PM117S	77,00
650	SV S	'03→'11	PM66S	79,50

FILTRI ARIA - AIR FILTERS

CC	Modello Model	Anno Years	Codice Code	€
650	SV X ABS	'18→'20	PM117S	77,00
750	GSX-R	'04→'05	PM24S	81,50
750	GSX-R	'06→'10	PM25S	78,50
750	GSXR	'11→'17	PM122S	84,00
750	GSX-R W	'92→'95	PM100S	51,00
1000	DL V-STROM	'02→'11	PM114S	77,00
1000	GSX-R	'05→'08	PM26S	80,50
1000	GSX-R	'09→'16	PM91S	78,50
1000	GSX-R (filtro P16)	'09→'16	PM91S16	* 157,00
1000	GSX-R (filtro PF1-85)	'09→'16	PM91SF1-85	* 199,00
1000	GSX-R	'17→'20	PM156S	90,00
1000	GSX-R (filtro PF1-85)	'17→'20	PM156SF1-85	* 199,00
1000	GSX-R R	'17→'20	PM156S	90,00
1000	GSX-R R (filtro PF1-85)	'17→'20	PM156SF1-85	* 199,00
1000	GSX-R ABS	'15→'16	PM91S	78,50
1000	GSX-R ABS (filtro P16)	'15→'16	PM91S16	* 157,00
1000	GSX-R ABS (filtro PF1-85)	'15→'16	PM91SF1-85	* 199,00
1000	GSX-S	'15→'17	PM91S	78,50
1000	GSX-S (filtro P16)	'15→'17	PM91S16	* 157,00
1000	GSX-S (filtro PF1-85)	'15→'17	PM91SF1-85	* 199,00
1000	GSX-S ABS	'15→'20	PM91S	78,50
1000	GSX-S ABS (filtro P16)	'15→'20	PM91S16	* 157,00
1000	GSX-S ABS (filtro PF1-85)	'15→'20	PM91SF1-85	* 199,00
1000	GSX-S ABS EVO	'18	PM91S	78,50
1000	GSX-S ABS EVO (filtro P16)	'18	PM91S16	* 157,00
1000	GSX-S ABS EVO (filtro PF1-85)	'18	PM91SF1-85	* 199,00
1000	GSX-S F	'15→'17	PM91S	78,50
1000	GSX-S F (filtro P16)	'15→'17	PM91S16	* 157,00
1000	GSX-S F (filtro PF1-85)	'15→'17	PM91SF1-85	* 199,00
1000	GSX-S F ABS	'15→'20	PM91S	78,50
1000	GSX-S F ABS (filtro P16)	'15→'20	PM91S16	* 157,00
1000	GSX-S F ABS (filtro PF1-85)	'15→'20	PM91SF1-85	* 199,00
1000	KATANA	'19→'20	PM91S	78,50
1000	KATANA (filtro P16)	'19→'20	PM91S16	* 157,00
1000	KATANA (filtro PF1-85)	'19→'20	PM91SF1-85	* 199,00
1000	KATANA S	'20→	PM91S	78,50
1000	KATANA S (filtro P16)	'20→	PM91S16	* 157,00
1000	KATANA S (filtro PF1-85)	'20→	PM91SF1-85	* 199,00
1000	SV N	'03→'07	PM66S	79,50
1000	SV S	'03→'07	PM66S	79,50
1000	TL R	'98→'02	CM97S	54,72
1000	TL S	'97→'01	CM97S	54,72
1100	GSX-R W	'93→'96	PM100S	51,00
1200	GSF BANDIT ABS	'06	PM67S	56,00
1200	GSF N BANDIT	'96→'05	PM100S	51,00
1200	GSF N BANDIT	'06→'06	PM67S	56,00
1200	GSF S BANDIT	'96→'05	PM100S	51,00
1200	GSF S BANDIT	'06	PM67S	56,00
1200	GSF S BANDIT ABS	'96→'05	PM100S	51,00
1200	GSF S BANDIT ABS	'06	PM67S	56,00
1250	GSF N BANDIT	'07→'12	PM67S	56,00
1250	GSF N BANDIT ABS	'07→'11	PM67S	56,00
1250	GSF S BANDIT	'07→'10	PM67S	56,00
1250	GSF S BANDIT ABS	'07→'16	PM67S	56,00
1250	GSX F ABS	'10→'16	PM67S	56,00
1250	GSX F ST TRAVELLER ABS	'10→'16	PM67S	56,00
1300	GSX-R HAYABUSA	'99→'07	CM69S	94,00
1300	GSX-R HAYABUSA	'08→'12	PM70S	85,50
1300	GSX-R HAYABUSA ABS	'13→'17	PM70S	85,50

(*) Questi articoli non hanno la solita scontistica ma un prezzo netto per il rivenditore.

FILTRI ARIA - AIR FILTERS

CC	Modello Model	Anno Years	Codice Code	€
TRIUMPH				
675	DAYTONA	'06→'12	PM60S	81,00
675	DAYTONA	'13	PM143S	84,00
675	DAYTONA (filtro P16)	'13	PM143S16	* 168,00
675	DAYTONA (filtro PF1-85)	'13	PM143SF1-85	* 199,00
675	DAYTONA ABS	'13→'17	PM143S	84,00
675	DAYTONA ABS (filtro P16)	'13→'17	PM143S16	* 168,00
675	DAYTONA ABS (filtro PF1-85)	'13→'17	PM143SF1-85	* 199,00
675	DAYTONA R	'11→'12	PM60S	81,00
675	DAYTONA R ABS	'13→'17	PM143S	84,00
675	DAYTONA R ABS (filtro P16)	'13→'17	PM143S16	* 168,00
675	DAYTONA R ABS (filtro PF1-85)	'13→'17	PM143SF1-85	* 199,00
675	STREET TRIPLE	'07→'12	PM60S	81,00
675	STREET TRIPLE	'13	PM143S	84,00
675	STREET TRIPLE (filtro P16)	'13	PM143S16	* 168,00
675	STREET TRIPLE (filtro PF1-85)	'13	PM143SF1-85	* 199,00
675	STREET TRIPLE ABS	'13→'17	PM143S	84,00
675	STREET TRIPLE ABS (filtro P16)	'13→'17	PM143S16	* 168,00
675	STREET TRIPLE ABS (filtro PF1-85)	'13→'17	PM143SF1-85	* 199,00
675	STREET TRIPLE R	'09→'12	PM60S	81,00
675	STREET TRIPLE R	'13	PM143S	84,00
675	STREET TRIPLE R (filtro P16)	'13	PM143S16	* 168,00
675	STREET TRIPLE R (filtro PF1-85)	'13	PM143SF1-85	* 199,00
675	STREET TRIPLE R ABS	'13→'16	PM143S	84,00
675	STREET TRIPLE R ABS (filtro P16)	'13→'16	PM143S16	* 168,00
675	STREET TRIPLE R ABS (filtro PF1-85)	'13→'16	PM143SF1-85	* 199,00
675	STREET TRIPLE RX ABS	'15→'16	PM143S	84,00
675	STREET TRIPLE RX ABS (filtro P16)	'15→'16	PM143S16	* 168,00
675	STREET TRIPLE RX ABS (filtro PF1-85)	'15→'16	PM143SF1-85	* 199,00
765	STREET TRIPLE R	'17→'19	PM167S	85,00
765	STREET TRIPLE R (filtro P037)	'17→'19	PM167S-WP	* 190,00
765	STREET TRIPLE R (filtro PF1-85)	'17→'19	PM167SF1-85	* 199,00
765	STREET TRIPLE RS	'17→'19	PM167S	85,00
765	STREET TRIPLE RS (filtro P037)	'17→'19	PM167S-WP	* 190,00
765	STREET TRIPLE RS (filtro PF1-85)	'17→'19	PM167SF1-85	* 199,00
765	STREET TRIPLE S	'17→'19	PM167S	85,00
765	STREET TRIPLE S (filtro P037)	'17→'19	PM167S-WP	* 190,00
765	STREET TRIPLE S (filtro PF1-85)	'17→'19	PM167SF1-85	* 199,00
800	TIGER	'11→'14	PM124S	73,00
800	TIGER (filtro P037)	'11→'14	PM124S-WP	* 146,00
800	TIGER ABS	'11→'14	PM124S	73,00
800	TIGER ABS (filtro P037)	'11→'14	PM124S-WP	* 146,00
800	TIGER XC	'11→'14	PM124S	73,00
800	TIGER XC (filtro P037)	'11→'14	PM124S-WP	* 146,00
800	TIGER XC ABS	'11→'20	PM124S	73,00
800	TIGER XC ABS (filtro P037)	'11→'20	PM124S-WP	* 146,00
800	TIGER XCA ABS	'16→'20	PM124S	73,00
800	TIGER XCA ABS (filtro P037)	'16→'20	PM124S-WP	* 146,00
800	TIGER XCX ABS	'15→'20	PM124S	73,00
800	TIGER XCX ABS (filtro P037)	'15→'20	PM124S-WP	* 146,00
800	TIGER XR ABS	'15→'20	PM124S	73,00
800	TIGER XR ABS (filtro P037)	'15→'20	PM124S-WP	* 146,00
800	TIGER XRT ABS	'15→'20	PM124S	73,00
800	TIGER XRT ABS (filtro P037)	'15→'20	PM124S-WP	* 146,00
800	TIGER XRX ABS	'15→'20	PM124S	73,00
800	TIGER XRX ABS (filtro P037)	'15→'20	PM124S-WP	* 146,00
865	BONNEVILLE EFI T100	'15	PM174S	78,00
865	BONNEVILLE EFI T100 (filtro P037)	'15	PM174S-WP	* 156,00
865	BONNEVILLE EFI T100 (filtro PF1-85)	'15	PM174SF1-85	* 199,00
865	BONNEVILLE EFI T100 BLACK	'15	PM174S	78,00
865	BONNEVILLE EFI T100 BLACK (filtro P037)	'15	PM174S-WP	* 156,00
865	BONNEVILLE EFI T100 BLACK (filtro PF1-85)	'15	PM174SF1-85	* 199,00

FILTRI ARIA - AIR FILTERS

CC	Modello Model	Anno Years	Codice Code	€
900	BONNEVILLE T100 ABS	'17→'19	PM174S	78,00
900	BONNEVILLE T100 ABS (filtro P037)	'17→'19	PM174S-WP	* 156,00
900	BONNEVILLE T100 ABS (filtro PF1-85)	'17→'19	PM174SF1-85	* 199,00
900	BONNEVILLE T100 BLACK ABS	'17→'19	PM174S	78,00
900	BONNEVILLE T100 BLACK ABS (filtro P037)	'17→'19	PM174S-WP	* 156,00
900	BONNEVILLE T100 BLACK ABS (filtro PF1-85)	'17→'19	PM174SF1-85	* 199,00
900	STREET CUP	'17→'19	PM174S	78,00
900	STREET CUP (filtro P037)	'17→'19	PM174S-WP	* 156,00
900	STREET CUP (filtro PF1-85)	'17→'19	PM174SF1-85	* 199,00
900	STREET SCRAMBLER	'17→'19	PM174S	78,00
900	STREET SCRAMBLER (filtro P037)	'17→'19	PM174S-WP	* 156,00
900	STREET SCRAMBLER (filtro PF1-85)	'17→'19	PM174SF1-85	* 199,00
900	STREET TWIN	'16→'19	PM174S	78,00
900	STREET TWIN (filtro P037)	'16→'19	PM174S-WP	* 156,00
900	STREET TWIN (filtro PF1-85)	'16→'19	PM174SF1-85	* 199,00
1050	SPEED TRIPLE	'05→'10	PM115S	77,00
1050	SPEED TRIPLE	'11→'16	PM123S	73,00
1050	SPEED TRIPLE 94 ABS	'15→'16	PM123S	73,00
1050	SPEED TRIPLE ABS	'07→'10	PM115S	77,00
1050	SPEED TRIPLE ABS	'11→'16	PM123S	73,00
1050	SPEED TRIPLE R ABS	'12→'17	PM123S	73,00
1050	SPEED TRIPLE R 94 ABS	'15→'16	PM123S	73,00
1050	SPEED TRIPLE R ABS	'16→'17	PM193S	84,00
1050	SPEED TRIPLE R ABS (filtro P037)	'16→'17	PM193S-WP	* 168,00
1050	SPEED TRIPLE R ABS (filtro PF1-85)	'16→'17	PM193SF1-85	* 199,00
1050	SPEED TRIPLE RS ABS	'18→'20	PM193S	84,00
1050	SPEED TRIPLE RS ABS (filtro P037)	'18→'20	PM193S-WP	* 168,00
1050	SPEED TRIPLE RS ABS (filtro PF1-85)	'18→'20	PM193SF1-85	* 199,00
1050	SPEED TRIPLE S ABS	'16→'20	PM193S	84,00
1050	SPEED TRIPLE S ABS (filtro P037)	'16→'20	PM193S-WP	* 168,00
1050	SPEED TRIPLE S ABS (filtro PF1-85)	'16→'20	PM193SF1-85	* 199,00
1050	SPRINT GT ABS	'10→'16	PM115S	77,00
1050	SPRINT I ST	'11→'12	PM115S	77,00
1050	SPRINT I ST ABS	'11→'12	PM115S	77,00
1050	SPRINT ST	'05→'10	PM115S	77,00
1050	SPRINT ST ABS	'05→'10	PM115S	77,00
1050	TIGER ABS	'07→'12	PM115S	77,00
1050	TIGER SE ABS	'10→'13	PM115S	77,00
1050	TIGER SPORT ABS	'13→'18	PM115S	77,00
1200	BONNEVILLE T120	'16→'19	PM174S	78,00
1200	BONNEVILLE T120 (filtro P037)	'16→'19	PM174S-WP	* 156,00
1200	BONNEVILLE T120 (filtro PF1-85)	'16→'19	PM174SF1-85	* 199,00
1200	BONNEVILLE T120 BLACK	'16→'19	PM174S	78,00
1200	BONNEVILLE T120 BLACK (filtro P037)	'16→'19	PM174S-WP	* 156,00
1200	BONNEVILLE T120 BLACK (filtro PF1-85)	'16→'19	PM174SF1-85	* 199,00

(*) Questi articoli non hanno la solita scontistica ma un prezzo netto per il rivenditore.

YAMAHA

125	MT	'15→'16	PM116S	63,20
125	MT ABS	'15→'19	PM116S	63,20
125	MT ABS	'20→	PM198S	55,00
125	MT ABS (filtro P037)	'20→	PM198S-WP	* 110,00
125	MT ABS (filtro PF1-85)	'20→	PM198SF1-85	* 199,00
125	WR R	'09→'16	PM116S	63,20
125	WR X SUPERMOTO	'09→'16	PM116S	63,20
125	X-CITY	'08→'15	PM107S	51,30
125	X-MAX	'06→'17	PM107S	51,30
125	X-MAX ABS	'11→'11	PM107S	51,30
125	YZF R	'08→'16	PM116S	63,20
125	YZF R ABS	'15→'18	PM116S	63,20
125	YZF R	'19→'20	PM198S	55,00
125	YZF R (filtro P037)	'19→'20	PM198S-WP	* 110,00

FILTRI ARIA - AIR FILTERS

CC	Modello Model	Anno Years	Codice Code	€
125	YZF R (filtro PF1-85)	'19→'20	PM198SF1-85	* 199,00
150	EXCITER	'15→'17	PM186S	50,00
150	EXCITER (filtro P037)	'15→'17	PM186S-WP	* 100,00
150	JUPITER	'15→'17	PM186S	50,00
150	JUPITER (filtro P037)	'15→'17	PM186S-WP	* 100,00
150	KING	'15→'17	PM186S	50,00
150	KING (filtro P037)	'15→'17	PM186S-WP	* 100,00
150	SNIPER	'15→'17	PM186S	50,00
150	SNIPER (filtro P037)	'15→'17	PM186S-WP	* 100,00
150	T EXCITER	'15→'17	PM186S	50,00
150	T EXCITER (filtro P037)	'15→'17	PM186S-WP	* 100,00
150	Y15 ZR	'15→'17	PM186S	50,00
150	Y15 ZR (filtro P037)	'15→'17	PM186S-WP	* 100,00
150	YZF R15	'17→'20	PM198S	55,00
150	YZF R15 (filtro P037)	'20→	PM198S-WP	* 110,00
150	YZF R15 (filtro PF1-85)	'20→	PM198SF1-85	* 199,00
155	AEROX	'17	PM185S	65,00
155	MIO AEROX	'17	PM185S	65,00
155	MT 15	'18→'20	PM198S	55,00
155	MT 15 (filtro P037)	'18→'20	PM198S-WP	* 110,00
155	MT 15 (filtro PF1-85)	'18→'20	PM198SF1-85	* 199,00
155	NVX	'17	PM185S	65,00
155	VIXION R	'18→'20	PM198S	55,00
155	VIXION R (filtro P037)	'18→'20	PM198S-WP	* 110,00
155	VIXION R (filtro PF1-85)	'18→'20	PM198SF1-85	* 199,00
155	XSR	'19→'20	PM198S	55,00
155	XSR (filtro P037)	'19→'20	PM198S-WP	* 110,00
155	XSR (filtro PF1-85)	'19→'20	PM198SF1-85	* 199,00
250	X-CITY	'07→'16	PM107S	51,30
250	X-CITY ABS	'14→'16	PM107S	51,30
250	X-MAX	'05→'16	PM107S	51,30
250	X-MAX - IRON MAX ABS	'16	PM107S	51,30
250	X-MAX ABS	'11→'15	PM107S	51,30
250	X-MAX SPORT	'11→'12	PM107S	51,30
250	YZF R 25	'15→'18	PM44S	62,00
300	X-MAX ABS	'17→'20	PM169S	89,00
300	X-MAX ABS IRON MAX	'19	PM169S	89,00
300	X-MAX TECH MAX	'20→	PM169S	89,00
321	MT-03 ABS	'16→'20	PM44S	62,00
321	YZF-R3 ABS	'15→'20	PM44S	62,00
400	SR 400	'14→'16	PM44S	62,00
500	T-MAX	'01→'07	PM34S	59,50
500	T-MAX	'08→'12	PM44S	62,00
500	T-MAX ABS	'08→'12	PM44S	62,00
530	T-MAX	'12→'16	PM44S	62,00
530	T-MAX ABS	'12→'16	PM44S	62,00
530	T-MAX	'17→'19	PM157S	74,50
530	T-MAX (filtro P16)	'17→'19	PM157S16	* 149,50
530	T-MAX BRONZE MAX	'12→'14	PM44S	62,00
530	T-MAX - LUX MAX ABS	'16→'16	PM44S	62,00
530	T-MAX ABS DX	'17→'19	PM157S	74,50
530	T-MAX ABS DX (filtro P16)	'17→'19	PM157S16	* 149,50
530	T-MAX ABS SX	'17→'19	PM157S	74,50
530	T-MAX ABS SX (filtro P16)	'17→'19	PM157S16	* 149,50
530	T-MAX SX SPORT EDITION ABS	'18→'19	PM157S	74,50
530	T-MAX SX SPORT EDITION ABS (filtro P16)	'17→'19	PM157S16	* 149,50
530	T-MAX BLACK MAX	'12→'14	PM44S	62,00
530	T-MAX BLACK MAX ABS	'12→'14	PM44S	62,00
530	T-MAX IRON MAX	'14→'16	PM44S	62,00
530	T-MAX IRON MAX ABS	'14→'16	PM44S	62,00
560	T-MAX ABS	'20→	PM192S	79,20
560	T-MAX ABS (filtro PF1-85)	'20→	PM192SF1-85	* 199,00

FILTRI ARIA - AIR FILTERS

CC	Modello Model	Anno Years	Codice Code	€
560	T-MAX ABS (filtro P037)	'20→	PM192S-WP	* 158,40
560	T-MAX TECH MAX ABS	'20→	PM192S	79,20
560	T-MAX TECH MAX ABS (filtro PF1-85)	'20→	PM192SF1-85	* 199,00
560	T-MAX TECH MAX ABS (filtro P037)	'20→	PM192S-WP	* 158,40
600	FZS FAZER	'98→'03	CM102S	53,20
600	FZ 6 N	'04→'07	PM71S	76,00
600	FZ 6 S FAZER	'04→'07	PM71S	76,00
600	FZ 6 S FAZER ABS	'06→'07	PM71S	76,00
600	FZ6 S2	'07→'10	PM71S	76,00
600	FZ6 S2 FAZER	'07→'09	PM71S	76,00
600	FZ6 S2 FAZER ABS	'08→'09	PM71S	76,00
600	YZF - R6	'99→'05	PM27S	84,34
600	YZF - R6	'06→'07	PM30S	93,00
600	YZF - R6 (filtro PF1-85)	'06→'07	PM30SF1-85	* 199,00
600	YZF - R6	'08→'20	PM50S	85,50
600	YZF - R6 (filtro PF1-85)	'08→'20	PM50SF1-85	* 199,00
660	MT - 03	'06→'14	PM42S	67,80
660	XT R	'04→'16	PM42S	67,80
660	XT X SUPERMOTO	'04→'16	PM42S	67,80
700	MT-07	'14→'16	CM148S	79,50
700	MT-07 ABS	'17→'20	CM148S	79,50
700	MT-07 MOTO CAGE ABS	'15→'17	CM148S	79,50
700	MT-07 TRACER ABS	'16→'20	CM148S	79,50
700	MT-07 TRACER GT	'19→'20	CM148S	79,50
700	XSR	'16→'20	CM148S	79,50
700	XSR XTRIBUTE	'19→'20	CM148S	79,50
700	XT Z TENERE	'19→'20	CM148S	79,50
800	FZ 8 N	'10→'16	PM72S	78,50
800	FZ 8 N ABS	'11→'15	PM72S	78,50
800	FZ 8 S FAZER	'10→'16	PM72S	78,50
800	FZ 8 S FAZER ABS	'11→'15	PM72S	78,50
850	NIKEN ABS (MXT)	'18→'20	PM149S	79,40
850	NIKEN GT ABS (MXT)	'19→'20	PM149S	79,40
900	MT-09	'13→'16	PM149S	79,40
900	MT-09 ABS	'14→'20	PM149S	79,40
900	MT-09 SP ABS	'18→'20	PM149S	79,40
900	MT-09 SPORT TRACKER ABS	'14→'17	PM149S	79,40
900	MT-09 STREET RALLY ABS	'14→'17	PM149S	79,40
900	MT-09 TRACER ABS	'15→'20	PM149S	79,40
900	MT-09 TRACER GT ABS	'15→'20	PM149S	79,40
900	XSR	'16→'20	PM149S	79,40
900	XSR 60TH ANNIVERSARY	'16→'16	PM149S	79,40
900	XSR ABARTH ABS	'16→'19	PM149S	79,40
900	XSR SPEEDBLOCK	'16→'17	PM149S	79,40
1000	FZ 1 N FAZER ABS	'08→'15	PM72S	78,50
1000	FZ 1 N	'06→'15	PM72S	78,50
1000	FZ 1 S FAZER	'06→'15	PM72S	78,50
1000	FZ 1 S FAZER ABS	'08→'15	PM72S	78,50
1000	FZS FAZER	'01→'06	CM98S	71,00
1000	MT-10	'16→'20	PM150S	95,00
1000	MT-10 (filtro P16)	'16→'20	PM150S16	* 180,00
1000	MT-10 (filtro PF1-85)	'16→'20	PM150SF1-85	* 199,00
1000	MT-10 SP	'17→'20	PM150S	95,00
1000	MT-10 SP (filtro P16)	'17→'20	PM150S16	* 180,00
1000	MT-10 SP (filtro PF1-85)	'17→'20	PM150SF1-85	* 199,00
1000	MT-10 TOURER EDITION	'17→'20	PM150S	95,00
1000	MT-10 TOURER EDITION (filtro P16)	'17→'20	PM150S16	* 180,00
1000	MT-10 TOURER EDITION (filtro PF1-85)	'17→'20	PM150SF1-85	* 199,00
1000	YZF R1	'98→'01	CM39S	71,00
1000	YZF R1	'07→'08	PM49S	80,50
1000	YZF R1	'09→'14	PM90S	80,00
1000	YZF R1 (filtro PF1-85)	'09→'14	PM90SF1-85	* 199,00

FILTRI ARIA - AIR FILTERS

CC	Modello Model	Anno Years	Codice Code	€
1000	YZF R1	'15→'20	PM150S	95,00
1000	YZF R1 (filtro P16)	'15→'20	PM150S16	* 180,00
1000	YZF R1 (filtro PF1-85)	'15→'20	PM150SF1-85	* 199,00
1000	YZF R1 60TH ANNIVERSARY	'15→'16	PM150S	95,00
1000	YZF R1 60TH ANNIVERSARY (filtro P16)	'15→'16	PM150S16	* 180,00
1000	YZF R1 60TH ANNIVERSARY (filtro PF1-85)	'15→'16	PM150SF1-85	* 199,00
1000	YZF R1-R1M	'15→'20	PM150S	95,00
1000	YZF R1-R1M (filtro P16)	'15→'20	PM150S16	* 180,00
1000	YZF R1-R1M (filtro PF1-85)	'15→'20	PM150SF1-85	* 199,00
1000	YZF-R1M 60TH ANNIVERSARY	'15→'16	PM150S	95,00
1000	YZF-R1M 60TH ANNIVERSARY (filtro P16)	'15→'16	PM150S16	* 180,00
1000	YZF-R1M 60TH ANNIVERSARY (filtro PF1-85)	'15→'16	PM150SF1-85	* 199,00
1000	YZF R1 SP	'06	PM49S	80,50
1000	YZF-R1 TCS	'12→'14	PM90S	80,00
1000	YZF R1 TCS (filtro PF1-85)	'12→'14	PM90SF1-85	* 199,00

(*) Questi articoli non hanno la solita scontistica ma un prezzo netto per il rivenditore.

FACTORY KITS

CC	Modello Model	Anno Years	Codice Code	€
BMW				
1000	S 1000 HP4 (il filtro d'aria non è inserito)	'13→'14	KITBM01	* 320,00
1000	S 1000 RR (il filtro d'aria non è inserito)	'09→'14	KITBM01	* 320,00
1000	S1000 RR - HP4 (il filtro d'aria non è inserito)	'15→'18	BM02KIT	* 600,00
HONDA				
600	CBR600 RR (il filtro d'aria non è inserito)	'13→	KITHO01	* 330,00
KAWASAKI				
600	ZX-6R (il filtro d'aria non è inserito)	'13→	KITKA01	* 320,00
1000	ZX-10R (il filtro d'aria non è inserito)	'11→'15	KITKA02	* 320,00
YAMAHA				
600	YZF R6 (il filtro d'aria non è inserito)	'08→	KITYA01	* 300,00
1000	YZF R1 (il filtro d'aria non è inserito)	'15→'18	A03KITY	* 600,00

BATTERIE

BATTERIE



nitro
A BATTERY FULL OF ENERGY®

 **motorquality**
TECHNOLOGY FOR SPORT

BATTERIE / BATTERY

Vecchio Codice <i>Old Code</i>	Nuovo Codice <i>New Code</i>	€	Confezione <i>Pachaging</i>
YB4L-B WA-N	NB4L-B WA	19,60	6,00
YT4L-BS-N	NT4L-BS	17,80	6,00
YB5L-B WA-N	NB5L-B WA	24,00	6,00
YTX5L-BS-N	NTX5L-BS	23,80	6,00
YB7L-B2 WA-N	NB7L-B2 WA	31,80	4,00
YT7B-BS-N	NT7B-BS	33,20	6,00
YTX7A-BS-N	NTX7A-BS	29,60	4,00
YTX7L-BS-N	NTX7L-BS	30,40	6,00
YTZ7S-BS-N	NTZ7S-BS	32,80	6,00
YB9-B WA-N	NB9-B WA	35,80	4,00
YT9B-BS-N	NT9B-BS	39,20	6,00
YTX9-BS-N	NTX9-BS	36,40	4,00
YTZ10S-BS-N	NTZ10S-BS	44,40	4,00
YB12AL-A2 WA-N	NB12AL-A2 WA	48,60	4,00
YT12A-BS-N	NT12A-BS	49,40	4,00
YT12B-BS-N	NT12B-BS	50,60	4,00
YTX12-BS-N	NTX12-BS	46,20	4,00
YTZ12S-BS-N	NTZ12S-BS	52,00	4,00
YB14L-A2 WA-N	NB14L-A2 WA	56,00	4,00
YTX14-BS-N	NTX14-BS	53,20	4,00
YTZ14S-BS-N	NTZ14S-BS	53,40	4,00
YB16AL-A2 WA-N	NB16AL-A2 WA	68,20	2,00
Y60-N30L-A WA-N	N60-N30L-A WA	106,00	2,00
51913 SEALED-N	51913 SLA	83,40	4,00





NB4L-B WA

EX: YB4L-B WA-N

Larghezza (±2 mm.)	120,00
Profondità (±2 mm.)	70,00
Altezza (±2 mm.)	92,00
Peso totale (Kg.)	1,50
Volume acido (L.)	0,30
Corrente di carica STD (A.)	0,40
Corrente di carica MAX (A.)	2,00
CCA	56,00

Disposizione
Polarità



Tipologia
Terminali



nitro
A BATTERY FULL OF ENERGY



NT4L-BS

EX: YT4L-BS-N

Larghezza (±2 mm.)	114,00
Profondità (±2 mm.)	71,00
Altezza (±2 mm.)	86,00
Peso totale (Kg.)	1,60
Volume acido (L.)	0,18
Corrente di carica STD (A.)	0,30
Corrente di carica MAX (A.)	1,50
CCA	40,00

Disposizione
Polarità

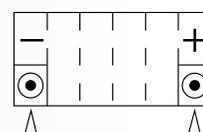

Tipologia
Terminali





NB5L-B WA

EX: YB5L-B WA-N

Larghezza (±2 mm.)	120,00
Profondità (±2 mm.)	60,00
Altezza (±2 mm.)	130,00
Peso totale (Kg.)	2,00
Volume acido (L.)	0,36
Corrente di carica STD (A.)	0,50
Corrente di carica MAX (A.)	2,50
CCA	65,00

Disposizione
Polarità

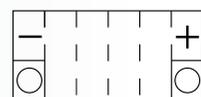

Tipologia
Terminali

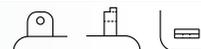

nitro
A BATTERY FULL OF ENERGY



NTX5L-BS

EX: YTX5L-BS-N

Larghezza (±2 mm.)	114,00
Profondità (±2 mm.)	71,00
Altezza (±2 mm.)	106,00
Peso totale (Kg.)	2,00
Volume acido (L.)	0,24
Corrente di carica STD (A.)	0,40
Corrente di carica MAX (A.)	2,00
CCA	80,00

Disposizione
Polarità

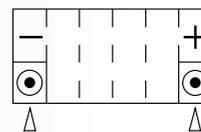

Tipologia
Terminali





NB7L-B2 WA

EX: YB7L-B2 WA-N

Larghezza (±2 mm.)	135,00
Profondità (±2 mm.)	75,00
Altezza (±2 mm.)	133,00
Peso totale (Kg.)	2,90
Volume acido (L.)	0,60
Corrente di carica STD (A.)	0,80
Corrente di carica MAX (A.)	4,00
CCA	124,00

Disposizione
Polarità

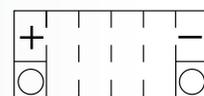

Tipologia
Terminali



nitro
A BATTERY FULL OF ENERGY



NT7B-BS

EX: YT7B-BS-N

Larghezza (±2 mm.)	150,00
Profondità (±2 mm.)	65,00
Altezza (±2 mm.)	93,00
Peso totale (Kg.)	2,70
Volume acido (L.)	0,33
Corrente di carica STD (A.)	0,70
Corrente di carica MAX (A.)	3,30
CCA	110,00

Disposizione
Polarità

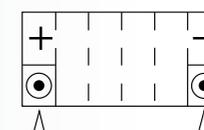

Tipologia
Terminali





NTX7A-BS

EX: YTX7A-BS-N

Larghezza (±2 mm.)	150,00
Profondità (±2 mm.)	87,00
Altezza (±2 mm.)	94,00
Peso totale (Kg.)	2,60
Volume acido (L.)	0,33
Corrente di carica STD (A.)	0,60
Corrente di carica MAX (A.)	3,00
CCA	105,00

Disposizione
Polarità

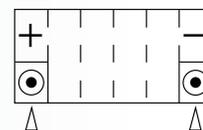

Tipologia
Terminali



NTX7L-BS

EX: YTX7L-BS-N

Larghezza (±2 mm.)	114,00
Profondità (±2 mm.)	71,00
Altezza (±2 mm.)	131,00
Peso totale (Kg.)	2,50
Volume acido (L.)	0,33
Corrente di carica STD (A.)	0,60
Corrente di carica MAX (A.)	3,00
CCA	100,00

Disposizione
Polarità

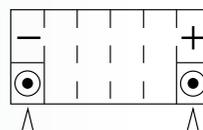

Tipologia
Terminali





NTZ7S-BS

EX: YTZ7S-BS-N

Larghezza (±2 mm.)	113,00
Profondità (±2 mm.)	70,00
Altezza (±2 mm.)	105,00
Peso totale (Kg.)	2,10
Volume acido (L.)	0,30
Corrente di carica STD (A.)	0,60
Corrente di carica MAX (A.)	3,00
CCA	130,00

Disposizione
Polarità

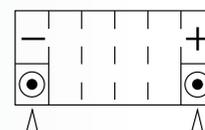

Tipologia
Terminali



nitro
A BATTERY FULL OF ENERGY



NB9-B WA

EX: YB9-B WA-N

Larghezza (±2 mm.)	135,00
Profondità (±2 mm.)	75,00
Altezza (±2 mm.)	139,00
Peso totale (Kg.)	3,10
Volume acido (L.)	0,60
Corrente di carica STD (A.)	0,90
Corrente di carica MAX (A.)	4,50
CCA	130,00

Disposizione
Polarità

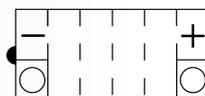

Tipologia
Terminali





NT9B-BS

EX: YT9B-BS-N

Larghezza (±2 mm.)	150,00
Profondità (±2 mm.)	70,00
Altezza (±2 mm.)	105,00
Peso totale (Kg.)	3,40
Volume acido (L.)	0,40
Corrente di carica STD (A.)	0,80
Corrente di carica MAX (A.)	4,00
CCA	120,00

Disposizione
Polarità

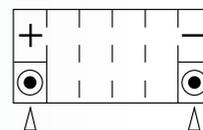

Tipologia
Terminali



nitro
A BATTERY FULL OF ENERGY



NTX9-BS

EX: YTX9-BS-N

Larghezza (±2 mm.)	150,00
Profondità (±2 mm.)	87,00
Altezza (±2 mm.)	105,00
Peso totale (Kg.)	3,00
Volume acido (L.)	0,40
Corrente di carica STD (A.)	0,80
Corrente di carica MAX (A.)	4,00
CCA	135,00

Disposizione
Polarità

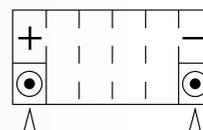

Tipologia
Terminali





NTZ10S-BS

EX: YTZ10S-BS-N

Larghezza (±2 mm.)	150,00
Profondità (±2 mm.)	87,00
Altezza (±2 mm.)	93,00
Peso totale (Kg.)	3,20
Volume acido (L.)	0,40
Corrente di carica STD (A.)	0,90
Corrente di carica MAX (A.)	4,30
CCA	190,00

Disposizione
Polarità

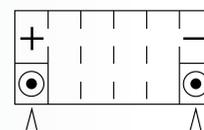

Tipologia
Terminali



nitro
A BATTERY FULL OF ENERGY



NB12AL-A2 WA

EX: YB12AL-A2 WA-N

Larghezza (±2 mm.)	134,00
Profondità (±2 mm.)	80,00
Altezza (±2 mm.)	160,00
Peso totale (Kg.)	4,00
Volume acido (L.)	0,75
Corrente di carica STD (A.)	1,20
Corrente di carica MAX (A.)	6,00
CCA	165,00

Disposizione
Polarità

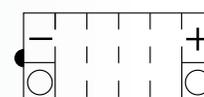

Tipologia
Terminali





NT12A-BS

EX: YT12A-BS-N

Larghezza (±2 mm.)	150,00
Profondità (±2 mm.)	87,00
Altezza (±2 mm.)	105,00
Peso totale (Kg.)	3,50
Volume acido (L.)	0,50
Corrente di carica STD (A.)	1,00
Corrente di carica MAX (A.)	5,00
CCA	175,00

Disposizione

Polarità

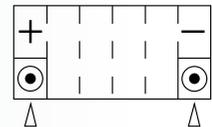

Tipologia

Terminali



nitro
A BATTERY FULL OF ENERGY



NT12B-BS

EX: YT12B-BS-N

Larghezza (±2 mm.)	150,00
Profondità (±2 mm.)	69,00
Altezza (±2 mm.)	130,00
Peso totale (Kg.)	4,10
Volume acido (L.)	0,50
Corrente di carica STD (A.)	1,00
Corrente di carica MAX (A.)	5,00
CCA	210,00

Disposizione

Polarità

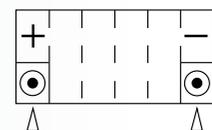

Tipologia

Terminali





NTX12-BS

EX: YTX12-BS-N

Larghezza (±2 mm.)	150,00
Profondità (±2 mm.)	87,00
Altezza (±2 mm.)	130,00
Peso totale (Kg.)	4,20
Volume acido (L.)	0,60
Corrente di carica STD (A.)	1,00
Corrente di carica MAX (A.)	5,00
CCA	180,00

Disposizione
Polarità

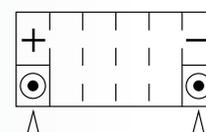

Tipologia
Terminali



nitro
A BATTERY FULL OF ENERGY



NTZ12S-BS

EX: YTZ12S-BS-N

Larghezza (±2 mm.)	150,00
Profondità (±2 mm.)	87,00
Altezza (±2 mm.)	110,00
Peso totale (Kg.)	3,70
Volume acido (L.)	0,60
Corrente di carica STD (A.)	1,10
Corrente di carica MAX (A.)	5,50
CCA	210,00

Disposizione
Polarità

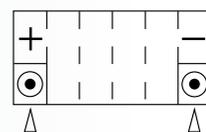

Tipologia
Terminali





NB14L-A2 WA

EX: YB14L-A2 WA-N

Larghezza (±2 mm.)	134,00
Profondità (±2 mm.)	89,00
Altezza (±2 mm.)	166,00
Peso totale (Kg.)	4,60
Volume acido (L.)	0,90
Corrente di carica STD (A.)	1,40
Corrente di carica MAX (A.)	7,00
CCA	190,00

Disposizione
Polarità

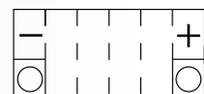

Tipologia
Terminali



nitro
A BATTERY FULL OF ENERGY



NTX14-BS

EX: YTX14-BS-N

Larghezza (±2 mm.)	150,00
Profondità (±2 mm.)	87,00
Altezza (±2 mm.)	145,00
Peso totale (Kg.)	4,60
Volume acido (L.)	0,69
Corrente di carica STD (A.)	1,20
Corrente di carica MAX (A.)	6,00
CCA	200,00

Disposizione
Polarità

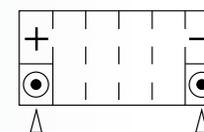

Tipologia
Terminali





NTZ14S-BS

EX: YTZ14S-BS-N

Larghezza (±2 mm.)	150,00
Profondità (±2 mm.)	87,00
Altezza (±2 mm.)	110,00
Peso totale (Kg.)	3,90
Volume acido (L.)	0,60
Corrente di carica STD (A.)	1,10
Corrente di carica MAX (A.)	5,60
CCA	230,00

Disposizione
Polarità

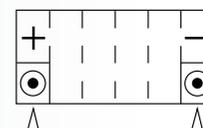

Tipologia
Terminali



nitro
A BATTERY FULL OF ENERGY



NB16AL-A2 WA

EX: YB16AL-A2 WA-N

Larghezza (±2 mm.)	207,00
Profondità (±2 mm.)	72,00
Altezza (±2 mm.)	164,00
Peso totale (Kg.)	5,30
Volume acido (L.)	1,10
Corrente di carica STD (A.)	1,60
Corrente di carica MAX (A.)	8,00
CCA	200,00

Disposizione
Polarità



Tipologia
Terminali

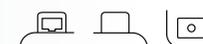



N60-N30L-A WA

EX: Y60-N30L-A WA-N

Larghezza (±2 mm.)	186,00
Profondità (±2 mm.)	130,00
Altezza (±2 mm.)	171,00
Peso totale (Kg.)	9,40
Volume acido (L.)	1,60
Corrente di carica STD (A.)	3,00
Corrente di carica MAX (A.)	15,00
CCA	300,00

Disposizione
Polarità

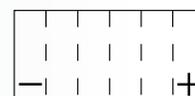

Tipologia
Terminali



nitro
A BATTERY FULL OF ENERGY



51913 SLA

EX: 51913 SEALED-N

Larghezza (±2 mm.)	178,00
Profondità (±2 mm.)	76,00
Altezza (±2 mm.)	167,00
Peso totale (Kg.)	5,60
Volume acido (L.)	1,00
Corrente di carica STD (A.)	2,00
Corrente di carica MAX (A.)	10,00
CCA	190,00

Disposizione
Polarità

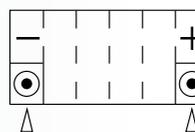

Tipologia
Terminali



BATTERIE / BATTERY

CC	Modello Model	Anno Years	Vecchio Codice Old Code	Nuovo Codice New Code
ADLY				
50	JET	'96	YT4L-BS-N	NT4L-BS
50	NB Noble	'08→'10	YT4L-BS-N	NT4L-BS
50	Panther	'02→'09	YT4L-BS-N	NT4L-BS
50	RS Supersonic	'00→'10	YT4L-BS-N	NT4L-BS
50	RT Road Tracer	'03→'06	YT4L-BS-N	NT4L-BS
50	Silver Fox	'00→'09	YT4L-BS-N	NT4L-BS
50	Supersonic	'04→'05	YT4L-BS-N	NT4L-BS
50	Thunderbike	'08→'09	YT4L-BS-N	NT4L-BS
125	GK Buggie	'01→'09	YTX7A-BS-N	NTX7A-BS
125	NB Noble	'08→'10	YTX7A-BS-N	NTX7A-BS
125	Supersonic	'04→'05	YTX7A-BS-N	NTX7A-BS
150	Crossroad Quad	'07→'09	YTX9-BS-N	NTX9-BS
150	Interceptor	'04→'06	YTX9-BS-N	NTX9-BS
150	Thunderbike	'03→'05	YTX7A-BS-N	NTX7A-BS
300	Cross X Road	'07→'09	YTX9-BS-N	NTX9-BS
300	Interceptor	'05→'07	YTX9-BS-N	NTX9-BS
300	Thunderbike	'04→'05	YTX9-BS-N	NTX9-BS
300	Utility	'05→'07	YTX9-BS-N	NTX9-BS
300	XS Quad	'07→'08	YTX9-BS-N	NTX9-BS

APRILIA

50	AE Pegaso	'92→'96	YB4L-B WA-N	NB4L-B WA
50	AE Red Rose	'92	YB4L-B WA-N	NB4L-B WA
50	AF1 Europa	'90→'92	YB4L-B WA-N	NB4L-B WA
50	AF1 Futura	'90→'92	YB4L-B WA-N	NB4L-B WA
50	AF1 Replica	'88→'92	YB4L-B WA-N	NB4L-B WA
50	AF1 Sintesi	'89	YB4L-B WA-N	NB4L-B WA
50	Amico	'96→'98	YB4L-B WA-N	NB4L-B WA
50	Area 51	'98→'02	YB4L-B WA-N	NB4L-B WA
50	Classic	'92→'01	YB4L-B WA-N	NB4L-B WA
50	ETX Tuareg	'87	YB4L-B WA-N	NB4L-B WA
50	Gulliver	'95→'98	YB4L-B WA-N	NB4L-B WA
50	Habana	'99→'02	YB4L-B WA-N	NB4L-B WA
50	Habana Custom	'99→'02	YB4L-B WA-N	NB4L-B WA
50	Mojito	'04→'10	YB4L-B WA-N	NB4L-B WA
50	Mojito Custom	'99→'12	YB4L-B WA-N	NB4L-B WA
50	Mojito Retro	'99→'03	YB4L-B WA-N	NB4L-B WA
50	MX	'03→'05	YB4L-B WA-N	NB4L-B WA
50	Rally (AIR Cooled)	'95→'02	YB4L-B WA-N	NB4L-B WA
50	Rally (Liq. Cooled)	'96→'00	YB4L-B WA-N	NB4L-B WA
50	RS	'93→'11	YB4L-B WA-N	NB4L-B WA
50	RS	'18→'19	YTX5L-BS-N	NTX5L-BS
50	RS4	'11→'20	YTX5L-BS-N	NTX5L-BS
50	RX	'06→'20	YB4L-B WA-N	NB4L-B WA
50	RX	'95→'01	YB4L-B WA-N	NB4L-B WA
50	RX C	'95→'04	YB4L-B WA-N	NB4L-B WA
50	RX Factory	'18→'20	YB4L-B WA-N	NB4L-B WA
50	RX Racing	'02→'06	YB4L-B WA-N	NB4L-B WA
50	Scarabeo	'93→'97	YB4L-B WA-N	NB4L-B WA
50	Scarabeo	'98→'98	YB4L-B WA-N	NB4L-B WA
50	Scarabeo	'98→'98	YB4L-B WA-N	NB4L-B WA
50	Scarabeo	'99→'05	YB4L-B WA-N	NB4L-B WA
50	Scarabeo 2T	'10→'12	YB4L-B WA-N	NB4L-B WA
50	Scarabeo 2T	'14→'14	YB4L-B WA-N	NB4L-B WA
50	Scarabeo 2T Net	'09→'10	YB4L-B WA-N	NB4L-B WA
50	Scarabeo 4T	'06→'09	YB4L-B WA-N	NB4L-B WA
50	Scarabeo 4T	'02→'06	YB4L-B WA-N	NB4L-B WA
50	Scarabeo 4T 4V	'10→'12	YB4L-B WA-N	NB4L-B WA
50	Scarabeo 4T 4V	'14→'17	YB4L-B WA-N	NB4L-B WA
50	Scar. 4T 4V Net	'09→'10	YB4L-B WA-N	NB4L-B WA

CC	Modello Model	Anno Years	Vecchio Codice Old Code	Nuovo Codice New Code
50	Scar. Classic 2T	'18→'19	YB4L-B WA-N	NB4L-B WA
50	Scarabeo Ditech	'01→'04	YB4L-B WA-N	NB4L-B WA
50	Scar. Quattro	'09→'09	YB4L-B WA-N	NB4L-B WA
50	Scarabeo Street	'05→'06	YB4L-B WA-N	NB4L-B WA
50	Scar. Street 2T	'06→'09	YB4L-B WA-N	NB4L-B WA
50	Scar. Street 2T	'18→'19	YB4L-B WA-N	NB4L-B WA
50	Sonic	'98→'08	YB4L-B WA-N	NB4L-B WA
50	Sportcity One 4T 2V E2	'08→'10	YB9-B WA-N	NB9-B WA
50	Sportcity One 4T 4V	'11→'12	YB9-B WA-N	NB9-B WA
50	SR	'93→'96	YB4L-B WA-N	NB4L-B WA
50	SR (carburatore)	'10→'14	YB9-B WA-N	NB9-B WA
50	SR (raff. aria)	'93→'01	YB4L-B WA-N	NB4L-B WA
50	SR (raff. liquido carburatore)	'00	YB4L-B WA-N	NB4L-B WA
50	SR (raff. liquido carburatore)	'00→'04	YB4L-B WA-N	NB4L-B WA
50	SR (raff. liquido carburatore)	'01→'01	YTX5L-BS-N	NTX5L-BS
50	SR (raff. liquido carburatore)	'02v04	YB4L-B WA-N	NB4L-B WA
50	SR (raff. liquido carburatore)	'03→'12	YB4L-B WA-N	NB4L-B WA
50	SR (raff. liquido carburatore)	'04→'09	YB9-B WA-N	NB9-B WA
50	SR (raff. liquido)	'94→'96	YB4L-B WA-N	NB4L-B WA
50	SR Ditech	'00	YB4L-B WA-N	NB4L-B WA
50	SR Ditech	'00→'01	YB4L-B WA-N	NB4L-B WA
50	SR Ditech	'01→'04	YTX5L-BS-N	NTX5L-BS
50	SR Ditech	'02→'04	YTX5L-BS-N	NTX5L-BS
50	SR Ditech E2	'02→'04	YTX5L-BS-N	NTX5L-BS
50	SR Factory	'04→'14	YB9-B WA-N	NB9-B WA
50	SR IE	'03→'12	YTX5L-BS-N	NTX5L-BS
50	SR IE (raff. liquido)	'04→'09	YB9-B WA-N	NB9-B WA
50	SR IE (raff. liquido)	'10→'14	YB9-B WA-N	NB9-B WA
50	SR Motard 2T E3	'12→'16	YB9-B WA-N	NB9-B WA
50	SR Motard 2T E4	'18	YTX5L-BS-N	NTX5L-BS
50	SR Motard 4T E3	'12→'13	YB9-B WA-N	NB9-B WA
50	SR Motard 4T V4	'13→'14	YB9-B WA-N	NB9-B WA
50	SR Motard 4T V4	'16	YB9-B WA-N	NB9-B WA
50	SR New Ditech	'04→'07	YB9-B WA-N	NB9-B WA
50	SR R	'04→'10	YB9-B WA-N	NB9-B WA
50	SR R	'04→'15	YB9-B WA-N	NB9-B WA
50	SR R	'13→'15	YB9-B WA-N	NB9-B WA
50	SR R	'18→'19	YTX5L-BS-N	NTX5L-BS
50	SR R Factory	'11→'12	YB9-B WA-N	NB9-B WA
50	SR R H2O 2T E4	'18→'18	YTX5L-BS-N	NTX5L-BS
50	SR R H2O GP Replica 2T E4	'19	YTX5L-BS-N	NTX5L-BS
50	SR R SBK Alitalia Replica	'10→'11	YB9-B WA-N	NB9-B WA
50	SR Stealth Racing	'97→'97	YTX5L-BS-N	NTX5L-BS
50	SR Stealth Racing	'97→'99	YB4L-B WA-N	NB4L-B WA
50	SR Stealth Racing	'98→'99	YB4L-B WA-N	NB4L-B WA
50	SR Street	'03→'16	YB9-B WA-N	NB9-B WA
50	SX Super Motard	'06→'17	YB4L-B WA-N	NB4L-B WA
50	SX Super Motard	'18→'20	YB4L-B WA-N	NB4L-B WA
50	SX Super Motard Factory	'18→'20	YB4L-B WA-N	NB4L-B WA
50	Tuono	'03→'05	YB4L-B WA-N	NB4L-B WA
100	Scarabeo	'00	YTX5L-BS-N	NTX5L-BS

BATTERIE / BATTERY

CC	Modello Model	Anno Years	Vecchio Codice Old Code	Nuovo Codice New Code	CC	Modello Model	Anno Years	Vecchio Codice Old Code	Nuovo Codice New Code
100	Scarabeo 4T	'06→'09	YB9-B WA-N	NB9-B WA	300	Scarabeo Light E3	'09→'11	YTX12-BS-N	NTX12-BS
100	Scarabeo 4T	'01→'05	YB9-B WA-N	NB9-B WA	300	Sport Cube	'11	YTX12-BS-N	NTX12-BS
100	Scarabeo 4T	'10→'12	YB9-B WA-N	NB9-B WA	300	Sportcity Cube IE	'08→'12	YTX12-BS-N	NTX12-BS
100	Scarabeo 4T	'14→'14	YB9-B WA-N	NB9-B WA	300	Sportcity Street	'12	YTX12-BS-N	NTX12-BS
100	Scar. 4T NET	'09	YB9-B WA-N	NB9-B WA	300	SR Max	'11→'16	YTX12-BS-N	NTX12-BS
100	Scar. 4T NET	'10	YB9-B WA-N	NB9-B WA	300		'08→'12	YTX12-BS-N	NTX12-BS
125	AF1 Europa	'90→'94	YB9-B WA-N	NB9-B WA	350	ETX Tuareg	'85→'87	YB14L-A2 WA-N	NB14L-A2 WA
125	AF1 Futura	'87→'89	YB9-B WA-N	NB9-B WA	350	ETX Tuareg Wind	'88→'89	YB9-B WA-N	NB9-B WA
125	AF1 Replica	'87→'88	YB9-B WA-N	NB9-B WA	400	Atlantic Sprint	'05→'08	YTX12-BS-N	NTX12-BS
125	AF1 Sintesi	'89→'90	YB9-B WA-N	NB9-B WA	400	Scarabeo Light	'06→'10	YTX12-BS-N	NTX12-BS
125	AF1 Sin. Sp. Pro	'92→'93	YB9-B WA-N	NB9-B WA	450	RXV	'06→'13	YTX7A-BS-N	NTX7A-BS
125	Atlantic	'07→'08	YTX9-BS-N	NTX9-BS	450	SXV Supermoto	'06→'13	YTX7A-BS-N	NTX7A-BS
125	Atlantic	'10→'13	YTX9-BS-N	NTX9-BS	450	SXV V.D.B. Rep.	'08	YTX7A-BS-N	NTX7A-BS
125	Classic	'95→'01	YB9-B WA-N	NB9-B WA	500	Atlantic	'01→'04	YB14L-A2 WA-N	NB14L-A2 WA
125	ETX	'99→'02	YB4L-B WA-N	NB4L-B WA	500	Atlantic Sprint	'05→'10	YTX12-BS-N	NTX12-BS
125	Habana	'00→'02	YTX9-BS-N	NTX9-BS	500	Scarabeo ABS	'03→'06	YB14L-A2 WA-N	NB14L-A2 WA
125	Habana Custom	'00→'02	YTX9-BS-N	NTX9-BS	500	Scarabeo Classic	'10→'12	YTX12-BS-N	NTX12-BS
125	Leonardo ST	'02→'02	YTX9-BS-N	NTX9-BS	500	Scarabeo GT ABS	'05→'07	YTX12-BS-N	NTX12-BS
125	MOJITO	'03→'12	YTX7L-BS-N	NTX7L-BS	500	Scarabeo IE	'07→'12	YTX12-BS-N	NTX12-BS
125	Mojito Custom	'03→'12	YTX7L-BS-N	NTX7L-BS	500	Scarabeo Light	'06→'06	YTX12-BS-N	NTX12-BS
125	Mojito E3	'08→'08	YTX7L-BS-N	NTX7L-BS	550	RXV	'06→'13	YTX7A-BS-N	NTX7A-BS
125	MX	'03→'07	YB4L-B WA-N	NB4L-B WA	550	SXV Supermoto	'06→'13	YTX7A-BS-N	NTX7A-BS
125	Pegaso	'89→'96	YB9-B WA-N	NB9-B WA	550	SXV V.D.B. Rep.	'08→'08	YTX7A-BS-N	NTX7A-BS
125	Red Rose	'88→'95	YB9-B WA-N	NB9-B WA	600	ETX Tuareg	'85→'87	YB14L-A2 WA-N	NB14L-A2 WA
125	RS	'92→'14	YB9-B WA-N	NB9-B WA	600	Pegaso	'90→'92	YB14L-A2 WA-N	NB14L-A2 WA
125	RS Extrema	'91→'95	YB9-B WA-N	NB9-B WA	600	Tuareg Wind	'87→'91	YB14L-A2 WA-N	NB14L-A2 WA
125	RS Replica	'94→'97	YB9-B WA-N	NB9-B WA	650	Pegaso	'93→'96	YB14L-A2 WA-N	NB14L-A2 WA
125	RS Sport PRO	'93→'99	YB9-B WA-N	NB9-B WA	650	Pegaso IE Factory	'06→'10	YTX12-BS-N	NTX12-BS
125	RS4	'11→'20	YTX7L-BS-N	NTX7L-BS	650	Pegaso IE Strada	'05→'10	YTX12-BS-N	NTX12-BS
125	RS4 GP Replica	'18→'20	YTX7L-BS-N	NTX7L-BS	650	Pegaso IE Trail	'06→'08	YTX12-BS-N	NTX12-BS
125	RX	'00→'01	YB4L-B WA-N	NB4L-B WA	750	Dorsoduro	'08→'12	YTX14-BS-N	NTX14-BS
125	RX	'08→'12	YB4L-B WA-N	NB4L-B WA	750	Dorsoduro ABS	'13→'16	YTX14-BS-N	NTX14-BS
125	RX E	'93→'99	YB4L-B WA-N	NB4L-B WA	750	Dorsoduro Factory	'10→'13	YTX12-BS-N	NTX12-BS
125	RX IE	'18→'20	YTX7L-BS-N	NTX7L-BS	750	Dorsod. Fact. ABS	'10→'13	YTX12-BS-N	NTX12-BS
125	RX R	'92→'95	YB4L-B WA-N	NB4L-B WA	750	Shiver	'07→'10	YTX14-BS-N	NTX14-BS
125	Scarabeo Light	'07→'10	YTX12-BS-N	NTX12-BS	750	Shiver	'10→'16	YTX12-BS-N	NTX12-BS
125	Scarabeo Light IE	'09→'12	YTX12-BS-N	NTX12-BS	750	Shiver ABS	'13→'16	YTX12-BS-N	NTX12-BS
125	Sportcity	'04→'08	YTX12-BS-N	NTX12-BS	750	Shiver GT	'09→'09	YTX14-BS-N	NTX14-BS
125	Sportcity Cube	'08→'12	YTX12-BS-N	NTX12-BS	750	Shiver GT ABS	'10→'13	YTX12-BS-N	NTX12-BS
125	Sportcity One	'08→'12	YB9-B WA-N	NB9-B WA	850	Mana	'07→'13	YTX14-BS-N	NTX14-BS
125	Sportcity Street	'12	YTX12-BS-N	NTX12-BS	850	Mana ABS	'13→'13	YTX14-BS-N	NTX14-BS
125	SR	'99→'02	YTX7L-BS-N	NTX7L-BS	850	Mana GT	'09→'13	YTX14-BS-N	NTX14-BS
125	SR Max	'11→'16	YTX14-BS-N	NTX14-BS	850	SRV	'12→'12	YTX14-BS-N	NTX14-BS
125	SR Motard	'12→'16	YB9-B WA-N	NB9-B WA	850	SRV ABS	'12→'14	YTX14-BS-N	NTX14-BS
125	SX	'08→'13	YB4L-B WA-N	NB4L-B WA	900	Dorsoduro ABS	'17→'20	YTX12-BS-N	NTX12-BS
125	SX IE	'18→'20	YTX7L-BS-N	NTX7L-BS	900	Shiver ABS	'17→'20	YTX12-BS-N	NTX12-BS
125	Tuareg	'88	YB9-B WA-N	NB9-B WA	1000	ETV Caponord	'01→'03	YTX14-BS-N	NTX14-BS
125	Tuareg Rally	'89→'94	YB9-B WA-N	NB9-B WA	1000	ETV Capon. ABS	'04→'08	YTX14-BS-N	NTX14-BS
125	Tuareg Wind	'88→'91	YB9-B WA-N	NB9-B WA	1000	ETV Capon. Rally	'01→'09	YTX14-BS-N	NTX14-BS
125	Tuono	'03→'07	YB9-B WA-N	NB9-B WA	1000	RST Futura	'01→'04	YTX12-BS-N	NTX12-BS
125	Tuono 4T	'17→'20	YTX7L-BS-N	NTX7L-BS	1000	RSV	'98→'04	YTX12-BS-N	NTX12-BS
150	Leonardo ST	'03→'04	YTX9-BS-N	NTX9-BS	1000	RSV Dream	'04→'08	YTX12-BS-N	NTX12-BS
150	Mojito	'03→'07	YTX7L-BS-N	NTX7L-BS	1000	RSV Factory	'04→'08	YTX12-BS-N	NTX12-BS
150	SR	'99→'02	YTX7L-BS-N	NTX7L-BS	1000	RSV R	'00→'08	YTX12-BS-N	NTX12-BS
200	Scarabeo Light	'07→'10	YTX12-BS-N	NTX12-BS	1000	RSV SP	'99→'00	YTX12-BS-N	NTX12-BS
200	Scarabeo Light IE	'09→'10	YTX12-BS-N	NTX12-BS	1000	RSV4 Aprc R	'11→'12	YT12A-BS-N	NT12A-BS
200	Sportcity	'06→'08	YTX12-BS-N	NTX12-BS	1000	RSV4 Aprc R ABS	'13→'14	YT12A-BS-N	NT12A-BS
200	Sportcity Cube	'08→'09	YT12B-BS-N	NT12B-BS	1000	RSV4 Aprc SE	'11→'12	YT12A-BS-N	NT12A-BS
250	RS	'95→'03	YB4L-B WA-N	NB4L-B WA	1000	RSV4 Aprc STD	'11→'12	YT12A-BS-N	NT12A-BS
250	Scarabeo Light E3	'06→'10	YTX12-BS-N	NTX12-BS	1000	RSV4 Factory	'09→'10	YTX12-BS-N	NTX12-BS
250	Sportcity Cube IE	'08→'12	YTX12-BS-N	NTX12-BS	1000	RSV4 Factory	'13→'14	YT12A-BS-N	NT12A-BS
250	Sportcity IE	'06→'08	YTX12-BS-N	NTX12-BS		Aprc ABS			

BATTERIE / BATTERY

CC	Modello Model	Anno Years	Vecchio Codice Old Code	Nuovo Codice New Code
1000	RSV4 R	'09→'10	YTX12-BS-N	NTX12-BS
1000	RSV4 RF	'15→'19	YT12A-BS-N	NT12A-BS
1000	RSV4 RR	'15→'20	YT12A-BS-N	NT12A-BS
1000	RSV4 RR Racer Pack	'15	YT12A-BS-N	NT12A-BS
1000	RSV4 SBK Rac.	'09→'10	YT12A-BS-N	NT12A-BS
1000	SL Falco	'99→'04	YTX14-BS-N	NTX14-BS
1000	Tuono	'02→'05	YTX12-BS-N	NTX12-BS
1000	Tuono R	'02→'10	YTX12-BS-N	NTX12-BS
1000	Tuono R Factory	'06→'10	YTX12-BS-N	NTX12-BS
1000	Tuono V4 R	'11→'15	YT12A-BS-N	NT12A-BS
1000	Tuono V4 R Aprc	'11→'13	YT12A-BS-N	NT12A-BS
1000	Tuono V4 R Aprc ABS	'13→'15	YT12A-BS-N	NT12A-BS
1100	RSV4 Factory	'19→'20	YT12A-BS-N	NT12A-BS
1100	Tuono V4 Fact.	'15→'20	YT12A-BS-N	NT12A-BS
1100	Tuono V4 RR	'15→'20	YT12A-BS-N	NT12A-BS
1200	Caponord	'13→'16	YTX14-BS-N	NTX14-BS
1200	Caponord Rally	'15→'19	YTX14-BS-N	NTX14-BS
1200	Caponord Travel Pack	'13→'17	YTX14-BS-N	NTX14-BS
1200	Dorsoduro	'10→'11	YTX14-BS-N	NTX14-BS
1200	Dorsoduro ABS	'12→'15	YTX14-BS-N	NTX14-BS

ARCTIC CAT

50	DVX	'06→'08	YTZ7S-BS-N	NTZ7S-BS
90	DVX	'06→'11	YTZ7S-BS-N	NTZ7S-BS
250	2X4	'99→'05	YB14L-A2 WA-N	NB14L-A2 WA
250	4X4	'99→'05	YB14L-A2 WA-N	NB14L-A2 WA
250	DVX	'06→'09	YTX12-BS-N	NTX12-BS
300	2X4	'98→'11	YB14L-A2 WA-N	NB14L-A2 WA
400	DVX	'04→'08	YTX9-BS-N	NTX9-BS

BAROSSA

50	Mini Python	'03→'05	YTX5L-BS-N	NTX5L-BS
100	Python	'03→'05	YTX5L-BS-N	NTX5L-BS
100	Sport	'03→'05	YTX5L-BS-N	NTX5L-BS
170	Baja	'03→'04	YTX7A-BS-N	NTX7A-BS
170	Cheetah	'03→'06	YTX7A-BS-N	NTX7A-BS
170	Magna	'03→'05	YTX7A-BS-N	NTX7A-BS
250	Puma Inverse	'06→'07	YTX9-BS-N	NTX9-BS
250	Quarterback	'05→'05	YTX7A-BS-N	NTX7A-BS
250	Quarterb Inverse	'06	YTX7A-BS-N	NTX7A-BS
250	Silverhawk Inverse	'06→'07	YTX9-BS-N	NTX9-BS

BENELLI

50	491 Army	'97→'01	YB4L-B WA-N	NB4L-B WA
50	491 GT	'97→'99	YB4L-B WA-N	NB4L-B WA
50	491 Naked	'99→'01	YB4L-B WA-N	NB4L-B WA
50	491 Racing	'97→'99	YB4L-B WA-N	NB4L-B WA
50	491 RR, GP	'00→'01	YB4L-B WA-N	NB4L-B WA
50	491 Sport	'97→'01	YB4L-B WA-N	NB4L-B WA
50	491 ST	'01→'03	YB4L-B WA-N	NB4L-B WA
50	491 Superbike	'97→'01	YB4L-B WA-N	NB4L-B WA
50	Devil	'92	YB4L-B WA-N	NB4L-B WA
50	K2	'98→'01	YB4L-B WA-N	NB4L-B WA
50	Pepe	'99→'01	YB4L-B WA-N	NB4L-B WA
50	Pepe	'03→'09	YB4L-B WA-N	NB4L-B WA
50	Pepe 2T	'10v'14	YB4L-B WA-N	NB4L-B WA
50	Pepe Classic	'10→'13	YB4L-B WA-N	NB4L-B WA
80	Devil	'92	YB4L-B WA-N	NB4L-B WA

CC	Modello Model	Anno Years	Vecchio Codice Old Code	Nuovo Codice New Code
100	K2	'99→'01	YB5L-B WA-N	NB5L-B WA
125	Adiva	'00→'02	YTX14-BS-N	NTX14-BS
125	BN	'18→'20	YTX7A-BS-N	NTX7A-BS
125	Caffènero	'11→'16	YTX7L-BS-N	NTX7L-BS
125	TNT Tom. Nak. T	'17→'20	YTX7A-BS-N	NTX7A-BS
125	TRK	'18→'20	YTX9-BS-N	NTX9-BS
125	Velvet	'99→'04	YTX9-BS-N	NTX9-BS
150	Adiva	'00→'04	YTX14-BS-N	NTX14-BS
150	Caffè Nero	'11→'15	YTX7L-BS-N	NTX7L-BS
150	Velvet	'99→'04	YTX9-BS-N	NTX9-BS
250	BN 251	'16→'20	YTX7L-BS-N	NTX7L-BS
250	Caffè Nero	'08→'13	YTX9-BS-N	NTX9-BS
250	Leoncino	'18→'20	YTX7L-BS-N	NTX7L-BS
250	Velvet	'99→'07	YTX12-BS-N	NTX12-BS
300	BN 302	'14→'18	YTX9-BS-N	NTX9-BS
300	BN 302 R	'17→'20	YTX9-BS-N	NTX9-BS
300	BN 302 S	'18→'20	YTX9-BS-N	NTX9-BS
350	Zenzero	'12→'17	YTX12-BS-N	NTX12-BS
354	Turismo, Sport	'83→'85	YB14L-A2 WA-N	NB14L-A2 WA
500	504 Sport	'76	YB14L-A2 WA-N	NB14L-A2 WA
500	Leoncino	'19→'20	YTX9-BS-N	NTX9-BS
500	Leoncino Trail	'17→'20	YTX9-BS-N	NTX9-BS
500	TRK 502	'16→'20	YTX9-BS-N	NTX9-BS
500	TRK 502 X	'18→'20	YTX9-BS-N	NTX9-BS
600	BN	'14→'16	YTX9-BS-N	NTX9-BS
600	BN GT	'14→'16	YTX9-BS-N	NTX9-BS
600	BN R	'14→'16	YTX9-BS-N	NTX9-BS
600	BN S	'14→'15	YTX9-BS-N	NTX9-BS
650	654 Sport	'83	YB14L-A2 WA-N	NB14L-A2 WA
750	SEI	'75	YB14L-A2 WA-N	NB14L-A2 WA
900	SEI	'83	Y60-N30L-A WA-N	N60-N30L-A WA
900	TNT 899	'12→'16	YTZ14S-BS-N	NTZ14S-BS
900	TNT 899 Century Racer	'11→'12	YTZ14S-BS-N	NTZ14S-BS
900	TNT 899S	'08→'09	YTZ14S-BS-N	NTZ14S-BS
900	TNT Cafe' Racer	'10	YTZ14S-BS-N	NTZ14S-BS
900	Tornado 3	'07→'16	YTZ14S-BS-N	NTZ14S-BS
900	Tre-K 899	'07→'16	YTZ14S-BS-N	NTZ14S-BS
1130	TNT	'06→'14	YTZ14S-BS-N	NTZ14S-BS
1130	TNT Cafe' Racer	'11→'14	YTZ14S-BS-N	NTZ14S-BS
1130	TNT Century Racer	'11	YTZ14S-BS-N	NTZ14S-BS
1130	TNT R	'11→'14	YTZ14S-BS-N	NTZ14S-BS
1130	TNT R160	'10→'14	YTZ14S-BS-N	NTZ14S-BS
1130	TNT Sport	'04→'06	YTZ14S-BS-N	NTZ14S-BS
1130	TNT Titanium	'05→'07	YTZ14S-BS-N	NTZ14S-BS
1130	Tornado Tre	'06→'07	YTZ14S-BS-N	NTZ14S-BS
1130	TRE K	'07→'12	YTZ14S-BS-N	NTZ14S-BS
1130	TRE K Amazonas	'07→'12	YTZ14S-BS-N	NTZ14S-BS

BETA

50	ARK	'96→'14	YB4L-B WA-N	NB4L-B WA
50	ARK	'97→'14	YB4L-B WA-N	NB4L-B WA
50	Eikon	'99→'06	YB4L-B WA-N	NB4L-B WA
50	Quadra	'97→'01	YB4L-B WA-N	NB4L-B WA
50	Tempo	'98→'02	YB4L-B WA-N	NB4L-B WA
125	ALP	'03→'07	YTX7L-BS-N	NTX7L-BS
125	ALP	'08→'15	YTX5L-BS-N	NTX5L-BS
125	Eikon	'00→'06	YTX9-BS-N	NTX9-BS
125	RR Enduro	'09→'16	YTX5L-BS-N	NTX5L-BS
125	RR Enduro	'09→'16	YTX5L-BS-N	NTX5L-BS
125	RR Enduro	'11→'20	YTX5L-BS-N	NTX5L-BS

BATTERIE / BATTERY

CC	Modello Model	Anno Years	Vecchio Codice Old Code	Nuovo Codice New Code	CC	Modello Model	Anno Years	Vecchio Codice Old Code	Nuovo Codice New Code
125	RR Motard	'08→'13	YTX5L-BS-N	NTX5L-BS	600	R 60 TIC	'78→'82	Y60-N30L-A WA-N	N60-N30L-A WA
125	RR Motard	'11→'20	YTX5L-BS-N	NTX5L-BS	650	C 650 GT	'11→'20	YTX14-BS-N	NTX14-BS
125	Urban	'08→'15	YTX5L-BS-N	NTX5L-BS	650	C 650 Sport	'15→'20	YTX14-BS-N	NTX14-BS
125	Urban Special	'09→'15	YTX5L-BS-N	NTX5L-BS	650	F 650	'93→'00	YB12AL-A2 WA-N	NB12AL-A2 WA
150	Eikon	'00→'06	YTX9-BS-N	NTX9-BS	650	F 650 CS Scarver	'00→'07	YB12AL-A2 WA-N	NB12AL-A2 WA
200	ALP	'03→'07	YTX7L-BS-N	NTX7L-BS	650	F 650 Funduro	'97→'03	YB12AL-A2 WA-N	NB12AL-A2 WA
200	ALP	'08→'15	YTX5L-BS-N	NTX5L-BS	650	F 650 GS	'99→'07	YB12AL-A2 WA-N	NB12AL-A2 WA
200	Urban	'08→'15	YTX5L-BS-N	NTX5L-BS	650	F 650 GS	'08→'12	YTX14-BS-N	NTX14-BS
200	Urban Special	'09→'15	YTX5L-BS-N	NTX5L-BS	650	F 650 GS 30	'11	YTX14-BS-N	NTX14-BS
250	RR Enduro	'05→'09	YTX5L-BS-N	NTX5L-BS		Years GS			
250	RR Enduro	'13→'16	YTX5L-BS-N	NTX5L-BS	650	F 650 GS Dakar	'99→'07	YB12AL-A2 WA-N	NB12AL-A2 WA
250	RR Enduro Racing	'13→'16	YTX5L-BS-N	NTX5L-BS	650	F 650 ST	'96→'02	YB12AL-A2 WA-N	NB12AL-A2 WA
250	X-Trainer	'19→'20	YTX5L-BS-N	NTX5L-BS	650	G 650 GS	'08→'15	YB12AL-A2 WA-N	NB12AL-A2 WA
300	RR Enduro	'13→'14	YTX5L-BS-N	NTX5L-BS	650	G 650 GS Sertão	'12→'14	YB12AL-A2 WA-N	NB12AL-A2 WA
300	RR Enduro Racing	'15→'16	YTX5L-BS-N	NTX5L-BS	650	G 650 Xchallenge	'07→'09	YTZ10S-BS-N	NTZ10S-BS
300	X-Trainer	'15→'20	YTX5L-BS-N	NTX5L-BS	650	G 650 XCountry	'06→'09	YTZ10S-BS-N	NTZ10S-BS
350	ALP 4.0	'05→'15	YTX7L-BS-N	NTX7L-BS	650	G 650 Xmoto	'07→'09	YTZ10S-BS-N	NTZ10S-BS
350	M4 Motard	'07→'15	YTX7L-BS-N	NTX7L-BS	650	R 65	'88→'89	Y60-N30L-A WA-N	N60-N30L-A WA
350	M4 Supermotard	'04→'06	YTX7L-BS-N	NTX7L-BS	650	R 65 G/S	'87→'92	51913 SEALED-N	51913 SLA
350	RR EFI Enduro	'15→'17	YTX5L-BS-N	NTX5L-BS	650	R 65 LS	'81→'85	51913 SEALED-N	51913 SLA
350	RR EFI End. Rac.	'15→'17	YTX5L-BS-N	NTX5L-BS	650	R 65 RT	'85→'88	Y60-N30L-A WA-N	N60-N30L-A WA
350	RR Enduro	'11→'12	YTX5L-BS-N	NTX5L-BS	650	R 65 T	'80→'85	51913 SEALED-N	51913 SLA
350	RR Enduro	'13→'15	YTX5L-BS-N	NTX5L-BS	700	F 700 GS	'11→'18	YTX14-BS-N	NTX14-BS
350	RR Enduro Racing	'13→'15	YTX5L-BS-N	NTX5L-BS	750	F 750 GS	'17→'20	YTX12-BS-N	NTX12-BS
390	RR EFI End. Rac.	'15	YTX5L-BS-N	NTX5L-BS	750	K 75	'84→'96	Y60-N30L-A WA-N	N60-N30L-A WA
390	RR EFI End. Rac.	'15	YTX5L-BS-N	NTX5L-BS	750	K 75 /2	'84→'96	Y60-N30L-A WA-N	N60-N30L-A WA
390	RR Enduro	'15	YTX5L-BS-N	NTX5L-BS	750	K 75 C	'85→'90	Y60-N30L-A WA-N	N60-N30L-A WA
390	RR Enduro Racing	'15	YTX5L-BS-N	NTX5L-BS	750	K 75 RT	'89→'96	Y60-N30L-A WA-N	N60-N30L-A WA
400	RR Enduro	'05→'14	YTX5L-BS-N	NTX5L-BS	750	K 75 S	'84→'96	Y60-N30L-A WA-N	N60-N30L-A WA
430	RR EFI Enduro	'16→'17	YTX5L-BS-N	NTX5L-BS	750	R 75 /5	'69→'73	51913 SEALED-N	51913 SLA
430	RR EFI End. Rac.	'16→'17	YTX5L-BS-N	NTX5L-BS	750	R 75 /6	'73→'76	Y60-N30L-A WA-N	N60-N30L-A WA
430	RR Enduro	'15	YTX5L-BS-N	NTX5L-BS	750	R 75 /7	'73→'79	Y60-N30L-A WA-N	N60-N30L-A WA
430	RR Enduro Racing	'15	YTX5L-BS-N	NTX5L-BS	800	F 800 GS	'08→'18	YTX14-BS-N	NTX14-BS
450	RR Cross Country	'12	YTX5L-BS-N	NTX5L-BS	800	F 800 GS 30	'11	YTX14-BS-N	NTX14-BS
450	RR Enduro	'05→'14	YTX5L-BS-N	NTX5L-BS		Years GS			
450	RR Enduro Racing	'06→'14	YTX5L-BS-N	NTX5L-BS	800	F 800 GS Adv.	'12→'18	YTX14-BS-N	NTX14-BS
480	RR EFI Enduro	'15	YTX5L-BS-N	NTX5L-BS	800	F 800 GS	'12	YTX14-BS-N	NTX14-BS
480	RR EFI End. Rac.	'15	YTX5L-BS-N	NTX5L-BS		Triple Black			
480	RR Enduro	'15	YTX5L-BS-N	NTX5L-BS	800	F 800 GS Trophy	'12	YTX14-BS-N	NTX14-BS
480	RR Enduro Racing	'15	YTX5L-BS-N	NTX5L-BS	800	F 800 GT	'11→'20	YTX14-BS-N	NTX14-BS
498	RR Enduro	'12→'14	YTX5L-BS-N	NTX5L-BS	800	F 800 R	'05→'20	YTX14-BS-N	NTX14-BS
498	RR Enduro Racing	'14	YTX5L-BS-N	NTX5L-BS	800	F 800 R Chris	'09→'11	YTX14-BS-N	NTX14-BS
520	RR Enduro	'10→'12	YTX5L-BS-N	NTX5L-BS		Pfeiffer Edition			
525	RR Enduro	'05→'09	YTX5L-BS-N	NTX5L-BS	800	F 800 S	'06→'11	YTX14-BS-N	NTX14-BS
525	RR Enduro Racing	'06	YTX5L-BS-N	NTX5L-BS	800	F 800 ST	'06→'12	YTX14-BS-N	NTX14-BS
525	RR Enduro Racing	'09	YTX5L-BS-N	NTX5L-BS	800	R 80	'77→'95	Y60-N30L-A WA-N	N60-N30L-A WA
					800	R 80 GS	'80→'87	51913 SEALED-N	51913 SLA
					800	R 80 GS	'87→'96	Y60-N30L-A WA-N	N60-N30L-A WA
					800	R 80 GS	'90→'95	Y60-N30L-A WA-N	N60-N30L-A WA
						Paris Dakar			
					800	R 80 MYSTIC	'94→'95	Y60-N30L-A WA-N	N60-N30L-A WA
					800	R 80 R	'91→'94	Y60-N30L-A WA-N	N60-N30L-A WA
					800	R 80 RT	'82→'95	Y60-N30L-A WA-N	N60-N30L-A WA
					800	R 80 ST	'82→'84	51913 SEALED-N	51913 SLA
					800	R 80 TIC	'78→'85	Y60-N30L-A WA-N	N60-N30L-A WA
					850	F 850 GS	'18→'20	YTX12-BS-N	NTX12-BS
					850	F 850 GS Adv.	'18→'20	YTX12-BS-N	NTX12-BS
					850	R 850 C	'97→'00	51913 SEALED-N	51913 SLA
					850	R 850 GS	'96→'00	51913 SEALED-N	51913 SLA
					850	R 850 GS ABS	'96→'00	51913 SEALED-N	51913 SLA
					850	R 850 R	'94→'07	51913 SEALED-N	51913 SLA
					850	R 850 RT	'95→'06	51913 SEALED-N	51913 SLA

BMW

0	C Ev. Electric	'14→'20	YTX9-BS-N	NTX9-BS
125	C1	'99→'03	YB14L-A2 WA-N	NB14L-A2 WA
200	C1	'01→'03	YB14L-A2 WA-N	NB14L-A2 WA
310	G 310 GS	'16→'20	YTX9-BS-N	NTX9-BS
310	G 310 R	'16→'20	YTX9-BS-N	NTX9-BS
400	C 400 GT	'19→'20	YTX9-BS-N	NTX9-BS
400	C 400 X	'18→'20	YTX9-BS-N	NTX9-BS
450	G 450 X	'08→'11	YTZ7S-BS-N	NTZ7S-BS
450	R 45 N	'78→'85	51913 SEALED-N	51913 SLA
500	R 50 /5	'69→'73	51913 SEALED-N	51913 SLA
600	C 600 Sport	'11→'15	YTX14-BS-N	NTX14-BS
600	R 60 /5	'69→'73	51913 SEALED-N	51913 SLA
600	R 60 /6	'73→'76	Y60-N30L-A WA-N	N60-N30L-A WA
600	R 60 /7	'76→'80	Y60-N30L-A WA-N	N60-N30L-A WA

BATTERIE / BATTERY

CC	Modello Model	Anno Years	Vecchio Codice Old Code	Nuovo Codice New Code
900	F 900 R	'20	YTX14-BS-N	NTX14-BS
900	F 900 XR	'20	YTX14-BS-N	NTX14-BS
900	R 90 /6	'73→'76	Y60-N30L-A WA-N	N60-N30L-A WA
900	R 90 S	'73→'76	Y60-N30L-A WA-N	N60-N30L-A WA
900	R 900 RT	'05→'10	51913 SEALED-N	51913 SLA
1000	HP4	'13→'14	YTZ10S-BS-N	NTZ10S-BS
1000	HP4	'13→'14	YTZ7S-BS-N	NTZ7S-BS
1000	K 1	'88→'93	Y60-N30L-A WA-N	N60-N30L-A WA
1000	K 1 ABS	'88→'93	Y60-N30L-A WA-N	N60-N30L-A WA
1000	K 100	'83→'89	Y60-N30L-A WA-N	N60-N30L-A WA
1000	K 100 /2	'87→'90	Y60-N30L-A WA-N	N60-N30L-A WA
1000	K 100 LT	'86→'91	Y60-N30L-A WA-N	N60-N30L-A WA
1000	K 100 RS	'83→'92	Y60-N30L-A WA-N	N60-N30L-A WA
1000	K 100 RT	'84→'89	Y60-N30L-A WA-N	N60-N30L-A WA
1000	R 100 /7	'76→'77	Y60-N30L-A WA-N	N60-N30L-A WA
1000	R 100 /7T	'77→'84	Y60-N30L-A WA-N	N60-N30L-A WA
1000	R 100 GS	'86→'94	Y60-N30L-A WA-N	N60-N30L-A WA
1000	R 100 GS Paris Dakar	'89→'96	Y60-N30L-A WA-N	N60-N30L-A WA
1000	R 100 R Mystic	'93→'96	Y60-N30L-A WA-N	N60-N30L-A WA
1000	R 100 R Roadster	'91→'97	Y60-N30L-A WA-N	N60-N30L-A WA
1000	R 100 RS	'76→'92	Y60-N30L-A WA-N	N60-N30L-A WA
1000	R 100 RT	'78→'95	Y60-N30L-A WA-N	N60-N30L-A WA
1000	R 100 S	'76→'80	Y60-N30L-A WA-N	N60-N30L-A WA
1000	S 1000 R (K47 - forged wheels)	'17→'20	YTX9-BS-N	NTX9-BS
1000	S 1000 R (K47)	'13→'20	YTX9-BS-N	NTX9-BS
1000	S 1000 RR (K46 forged wheels)	'15→'16	YTZ10S-BS-N	NTZ10S-BS
1000	S 1000 RR (K46 forged wheels)	'15→'16	YTZ7S-BS-N	NTZ7S-BS
1000	S 1000 RR (K46 forged wheels)	'17→'18	YTX9-BS-N	NTX9-BS
1000	S 1000 RR (K46)	'09→'16	YTZ10S-BS-N	NTZ10S-BS
1000	S 1000 RR (K46)	'14→'16	YTZ7S-BS-N	NTZ7S-BS
1000	S 1000 RR (K46)	'17→'18	YTX9-BS-N	NTX9-BS
1000	S 1000 RR (K67)	'19→'20	YTX9-BS-N	NTX9-BS
1000	S 1000 XR (K49)	'15→'19	YTX9-BS-N	NTX9-BS
1000	S 1000 XR (K69)	'20	YTX9-BS-N	NTX9-BS
1100	K 1100 LT	'89→'99	51913 SEALED-N	51913 SLA
1100	K 1100 LT ABS	'93→'99	51913 SEALED-N	51913 SLA
1100	K 1100 RS	'92→'96	51913 SEALED-N	51913 SLA
1100	K 1100 RS ABS	'92→'96	51913 SEALED-N	51913 SLA
1100	R 1100 GS	'93→'99	51913 SEALED-N	51913 SLA
1100	R 1100 GS ABS	'93→'99	51913 SEALED-N	51913 SLA
1100	R 1100 R	'93→'01	51913 SEALED-N	51913 SLA
1100	R 1100 RS	'92→'01	51913 SEALED-N	51913 SLA
1100	R 1100 RT	'94→'01	51913 SEALED-N	51913 SLA
1100	R 1100 RT ABS	'94→'01	51913 SEALED-N	51913 SLA
1100	R 1100 S	'96→'06	51913 SEALED-N	51913 SLA
1100	R 1100 S ABS	'00→'06	51913 SEALED-N	51913 SLA
1150	R 1150 GS	'99→'04	51913 SEALED-N	51913 SLA
1150	R 1150 GS ABS	'99→'04	51913 SEALED-N	51913 SLA
1150	R 1150 GS Adv.	'02→'05	51913 SEALED-N	51913 SLA
1150	R 1150 GS Adv. (Integral ABS)	'02→'05	51913 SEALED-N	51913 SLA
1150	R 1150 R	'99→'06	51913 SEALED-N	51913 SLA
1150	R 1150 R Rockster	'03→'06	51913 SEALED-N	51913 SLA
1150	R 1150 RS	'01→'05	51913 SEALED-N	51913 SLA
1150	R 1150 RS ABS	'01→'05	51913 SEALED-N	51913 SLA
1150	R 1150 RT	'00→'06	51913 SEALED-N	51913 SLA

CC	Modello Model	Anno Years	Vecchio Codice Old Code	Nuovo Codice New Code
1150	R 1150 RT ABS	'00→'06	51913 SEALED-N	51913 SLA
1170	HP2 Enduro	'05→'08	YTX14-BS-N	NTX14-BS
1170	HP2 Megamoto	'07→'11	YTX14-BS-N	NTX14-BS
1170	HP2 Sport	'08→'11	YTX14-BS-N	NTX14-BS
1170	R Ninet	'13→'20	YTX14-BS-N	NTX14-BS
1170	R Ninet Cafe Rac.	'19→'20	YTX14-BS-N	NTX14-BS
1170	R Ninet Pure	'17→'20	YTX14-BS-N	NTX14-BS
1170	R Ninet Racer	'17→'20	YTX14-BS-N	NTX14-BS
1170	R Ninet Scrambler	'16→'20	YTX14-BS-N	NTX14-BS
1170	R Ninet Urban GS	'17→'20	YTX14-BS-N	NTX14-BS
1200	K 1200 GT	'03→'08	51913 SEALED-N	51913 SLA
1200	K 1200 LT	'97→'09	51913 SEALED-N	51913 SLA
1200	K 1200 R	'05→'08	YTX14-BS-N	NTX14-BS
1200	K 1200 R Sport	'07→'11	YTX14-BS-N	NTX14-BS
1200	K 1200 RS	'96→'04	51913 SEALED-N	51913 SLA
1200	K 1200 RS ABS	'96→'04	51913 SEALED-N	51913 SLA
1200	K 1200 S	'03→'08	YTX14-BS-N	NTX14-BS
1200	R 1200 C	'97→'05	51913 SEALED-N	51913 SLA
1200	R 1200 C ABS	'97→'05	51913 SEALED-N	51913 SLA
1200	R 1200 C Classic	'03→'04	51913 SEALED-N	51913 SLA
1200	R 1200 C Indep.	'00→'04	51913 SEALED-N	51913 SLA
1200	R 1200 C Mont.	'04	51913 SEALED-N	51913 SLA
1200	R 1200 CL	'02→'04	51913 SEALED-N	51913 SLA
1200	R 1200 GS	'04→'18	YTX14-BS-N	NTX14-BS
1200	R 1200 GS Adv.	'06→'18	YTX14-BS-N	NTX14-BS
1200	R 1200 GS Rallye	'12	YTX14-BS-N	NTX14-BS
1200	R 1200 GS Rallye	'17→'18	YTX14-BS-N	NTX14-BS
1200	R 1200 R	'06→'18	YTX14-BS-N	NTX14-BS
1200	R 1200 R Classic	'11→'12	YTX14-BS-N	NTX14-BS
1200	R 1200 RS	'15→'18	YTX14-BS-N	NTX14-BS
1200	R 1200 RT	'05→'14	51913 SEALED-N	51913 SLA
1200	R 1200 S	'05→'08	YTX14-BS-N	NTX14-BS
1200	R 1200 ST	'03→'08	YTX14-BS-N	NTX14-BS
1250	R 1250 GS	'19→'20	YTX14-BS-N	NTX14-BS
1250	R 1250 GS Adv.	'19→'20	YTX14-BS-N	NTX14-BS
1250	R 1250 R	'19→'20	YTX14-BS-N	NTX14-BS
1250	R 1250 RS	'19→'20	YTX14-BS-N	NTX14-BS
1250	R 1250 RT	'19→'20	51913 SEALED-N	51913 SLA
1250	R 1250 RT Sport	'19→'20	51913 SEALED-N	51913 SLA
1300	K 1300 GT	'09→'11	51913 SEALED-N	51913 SLA
1300	K 1300 R	'07→'12	YTX14-BS-N	NTX14-BS
1300	K 1300 S	'07→'16	YTX14-BS-N	NTX14-BS
1600	K 1600 Bagger	'17→'20	51913 SEALED-N	51913 SLA
1600	K 1600 GT	'11→'16	51913 SEALED-N	51913 SLA
1600	K 1600 GTL	'11→'19	51913 SEALED-N	51913 SLA
1600	K 1600 GTL Exc.	'13→'16	51913 SEALED-N	51913 SLA

BOMBARDIER-CAN AM

90	DS X	'08→'11	YT4L-BS-N	NT4L-BS
250	DS	'07→'11	YTX12-BS-N	NTX12-BS
450	DS	'08→'10	YT7B-BS-N	NT7B-BS
450	DS X	'08→'09	YT7B-BS-N	NT7B-BS
450	DS XXC/XXM	'10→'10	YT7B-BS-N	NT7B-BS

BUELL

492	Blast	'00→'07	YTX14-BS-N	NTX14-BS
984	XB9 R Firebolt	'02→'07	YTX14-BS-N	NTX14-BS
984	XB9 S Lightning	'03→'04	YTX14-BS-N	NTX14-BS
984	XB9 SX Lightning City X	'05→'10	YTX14-BS-N	NTX14-BS
1200	S1 Lightning	'94→'00	YTX14-BS-N	NTX14-BS
1200	S1 White Light.	'98→'99	YTX14-BS-N	NTX14-BS

BATTERIE / BATTERY

CC	Modello Model	Anno Years	Vecchio Codice Old Code	Nuovo Codice New Code
1200	XB12 R Firebolt	'04→'10	YTX14-BS-N	NTX14-BS
1200	XB12 S Light.	'04→'08	YTX14-BS-N	NTX14-BS
1200	XB12 SCG Light.	'06→'10	YTX14-BS-N	NTX14-BS
1200	XB12 SS Lightning Long	'06→'10	YTX14-BS-N	NTX14-BS
1200	XB12 STT Lightning Super	'06→'08	YTX14-BS-N	NTX14-BS
1200	XB12 X Ulysses	'06→'10	YTX14-BS-N	NTX14-BS
1200	XB12 XT Ulysses	'08→'10	YTX14-BS-N	NTX14-BS

BULTACO

50	Lobito	'99→'99	YB4L-B WA-N	NB4L-B WA
50	SM Astro	'01→'01	YB4L-B WA-N	NB4L-B WA

CAGIVA

50	City	'94→'94	YT4L-BS-N	NT4L-BS
50	City Lucky	'95→'97	YT4L-BS-N	NT4L-BS
50	K3	'91→'93	YB4L-B WA-N	NB4L-B WA
125	Cruiser	'87→'89	YB9-B WA-N	NB9-B WA
125	Freccia C10	'89→'89	YB9-B WA-N	NB9-B WA
125	Freccia C12	'89→'92	YB9-B WA-N	NB9-B WA
125	K7	'89→'92	YB4L-B WA-N	NB4L-B WA
125	Mito	'90→'92	YB9-B WA-N	NB9-B WA
125	Mito 525 SP	'08→'12	YB9-B WA-N	NB9-B WA
125	Mito EV	'94→'07	YB9-B WA-N	NB9-B WA
125	N 90	'90→'92	YB9-B WA-N	NB9-B WA
125	Planet	'97→'03	YB9-B WA-N	NB9-B WA
125	Super City	'91→'00	YB9-B WA-N	NB9-B WA
125	Supercity	'91→'00	YB9-B WA-N	NB9-B WA
125	Tamanaco	'88→'91	YB9-B WA-N	NB9-B WA
125	W8	'92→'96	YB4L-B WA-N	NB4L-B WA
125	W8	'93→'98	YB4L-B WA-N	NB4L-B WA
350	W12	'93→'96	YB14L-A2 WA-N	NB14L-A2 WA
500	Canyon	'91→'00	YTX14-BS-N	NTX14-BS
500	T4E-R	'87→'90	YB14L-A2 WA-N	NB14L-A2 WA
600	Canyon	'96→'99	YTX14-BS-N	NTX14-BS
600	River	'96→'99	YB14L-A2 WA-N	NB14L-A2 WA
600	W16	'94→'98	YB14L-A2 WA-N	NB14L-A2 WA
650	Raptor	'01→'05	YTX9-BS-N	NTX9-BS
650	Raptor IE	'06→'07	YTX9-BS-N	NTX9-BS
650	V-Raptor	'05→'07	YTX9-BS-N	NTX9-BS
1000	Navigator	'00→'05	YT12B-BS-N	NT12B-BS
1000	Raptor	'00→'05	YTX9-BS-N	NTX9-BS
1000	V-Raptor	'00→'05	YTX9-BS-N	NTX9-BS
1000	X-TRA Raptor	'00→'05	YTX9-BS-N	NTX9-BS

CANNONDALE

400	FX	'01→'01	YTX9-BS-N	NTX9-BS
440	Blaze	'02→'03	YTX9-BS-N	NTX9-BS
440	Cannibal	'02→'03	YTX9-BS-N	NTX9-BS
440	Glamis	'02→'03	YTX9-BS-N	NTX9-BS
440	Moto	'02→'03	YTX9-BS-N	NTX9-BS
440	Speed	'02→'03	YTX9-BS-N	NTX9-BS

CCM

404	404 DS	'03→'04	YT7B-BS-N	NT7B-BS
404	404 DS Superm.	'03→'09	YT7B-BS-N	NT7B-BS
404	404 DS Trail	'07→'09	YT7B-BS-N	NT7B-BS
404	404 E	'03→'04	YT7B-BS-N	NT7B-BS
604	E DS Dual Sport/Trail	'98→'03	YTX9-BS-N	NTX9-BS

CC	Modello Model	Anno Years	Vecchio Codice Old Code	Nuovo Codice New Code
604	E Supermoto	'99→'03	YTX9-BS-N	NTX9-BS
604	RS Roadster	'00→'03	YTX9-BS-N	NTX9-BS
644	DS	'04→'04	YTX9-BS-N	NTX9-BS
644	DS Supermoto	'04	YTX9-BS-N	NTX9-BS
644	R 30	'02→'04	YTX9-BS-N	NTX9-BS
644	R30 Supermoto	'99→'03	YTX9-BS-N	NTX9-BS

CF MOTO

650	GT	'20	YTX12-BS-N	NTX12-BS
650	NK	'12→'15	YTX12-BS-N	NTX12-BS
650	NK	'16→'20	YTX12-BS-N	NTX12-BS
650	TK	'13→'15	YTX12-BS-N	NTX12-BS
650	TR	'13→'14	YTX12-BS-N	NTX12-BS

DAELIM

125	Altino	'01→'04	YTX9-BS-N	NTX9-BS
125	Roadsport FI	'08→'16	YTX12-BS-N	NTX12-BS
125	Roadwin	'04→'13	YTX12-BS-N	NTX12-BS
125	Roadwin FI R	'08→'12	YTX12-BS-N	NTX12-BS
125	S2 Freewing	'07→'09	YTX12-BS-N	NTX12-BS
125	VC-S	'95→'97	YTX9-BS-N	NTX9-BS
125	VS	'98→'99	YTX9-BS-N	NTX9-BS
125	VS Evolution	'00→'04	YTX9-BS-N	NTX9-BS
250	Roadsport	'10→'14	YTX12-BS-N	NTX12-BS
250	SV S3	'12→'14	YTX12-BS-N	NTX12-BS

DERBI

50	Atlantis	'99→'02	YB4L-B WA-N	NB4L-B WA
50	Atlantis	'04→'06	YB4L-B WA-N	NB4L-B WA
50	Atlantis	'07	YB4L-B WA-N	NB4L-B WA
50	Atlantis	'07	YB4L-B WA-N	NB4L-B WA
50	Atlantis	'07→'09	YB4L-B WA-N	NB4L-B WA
50	Atlantis	'08→'11	YB4L-B WA-N	NB4L-B WA
50	Atlantis Bullet	'03→'05	YB4L-B WA-N	NB4L-B WA
50	Atlantis City	'03→'06	YB4L-B WA-N	NB4L-B WA
50	Atlantis Red Bullet	'03	YB4L-B WA-N	NB4L-B WA
50	Atlantis Two Chic	'05	YB4L-B WA-N	NB4L-B WA
50	Boulevard	'09→'12	YB4L-B WA-N	NB4L-B WA
50	Boulevard	'09	YB4L-B WA-N	NB4L-B WA
50	DRD R Black Devil Edition	'04→'05	YB4L-B WA-N	NB4L-B WA
50	DRD R Limited	'04→'05	YB4L-B WA-N	NB4L-B WA
50	DRD R Lim. Rac.	'07→'08	YB4L-B WA-N	NB4L-B WA
50	DRD R Senda Pro	'05→'06	YB4L-B WA-N	NB4L-B WA
50	DRD R Senda Pro	'07→'16	YTX5L-BS-N	NTX5L-BS
50	DRD R Senda Rac.	'02→'03	YB4L-B WA-N	NB4L-B WA
50	DRD R Senda Rac.	'06→'13	YTX5L-BS-N	NTX5L-BS
50	DRD SM Black Devil Edition	'04→'05	YB4L-B WA-N	NB4L-B WA
50	DRD SM Senda EVO	'08→'11	YTX5L-BS-N	NTX5L-BS
50	DRD SM Senda Limited	'04→'05	YB4L-B WA-N	NB4L-B WA
50	DRD SM Senda PRO	'05→'06	YB4L-B WA-N	NB4L-B WA
50	DRD SM Senda PRO	'07→'13	YTX5L-BS-N	NTX5L-BS
50	DRD SM Senda Racing	'02→'03	YB4L-B WA-N	NB4L-B WA
50	DRD SM Senda Racing	'04→'17	YTX5L-BS-N	NTX5L-BS

BATTERIE / BATTERY

CC	Modello Model	Anno Years	Vecchio Codice Old Code	Nuovo Codice New Code
50	DRD SM Senda Racing Limited	'07→'08	YB4L-B WA-N	NB4L-B WA
50	DRD SM Senda X-Treme	'11→'13	YB4L-B WA-N	NB4L-B WA
50	DRD SM Supermoto/Racer	'03→'04	YB4L-B WA-N	NB4L-B WA
50	Fenix	'96→'98	YB4L-B WA-N	NB4L-B WA
50	FL VAMOS	'96→'99	YB4L-B WA-N	NB4L-B WA
50	GP1	'01→'03	YB4L-B WA-N	NB4L-B WA
50	GP1 Euro 2	'05→'05	YB4L-B WA-N	NB4L-B WA
50	GP1 Open	'06→'11	YB4L-B WA-N	NB4L-B WA
50	GP1 Race	'05→'07	YTX5L-BS-N	NTX5L-BS
50	GPR	'97→'00	YB4L-B WA-N	NB4L-B WA
50	GPR	'04→'07	YB4L-B WA-N	NB4L-B WA
50	GPR	'09→	YB4L-B WA-N	NB4L-B WA
50	GPR Nude	'04→'09	YTX5L-BS-N	NTX5L-BS
50	GPR Racing	'08→'10	YTX7L-BS-N	NTX7L-BS
50	GPR Racing	'11→'13	YTX7L-BS-N	NTX7L-BS
50	GPR Replica	'98→'01	YB4L-B WA-N	NB4L-B WA
50	GPR Rep. Rac.	'02→'03	YB4L-B WA-N	NB4L-B WA
50	Hunter	'99→'99	YB4L-B WA-N	NB4L-B WA
50	LC Atlantis	'99→'01	YB4L-B WA-N	NB4L-B WA
50	Paddock	'98→'99	YB4L-B WA-N	NB4L-B WA
50	Predator	'98→'03	YB4L-B WA-N	NB4L-B WA
50	Predator	'98→'03	YB4L-B WA-N	NB4L-B WA
50	Predator	'98→'01	YB4L-B WA-N	NB4L-B WA
50	R Senda R1	'00→'01	YB4L-B WA-N	NB4L-B WA
50	R Senda Racer	'01→'03	YB4L-B WA-N	NB4L-B WA
50	R Senda X Race	'04→'11	YB4L-B WA-N	NB4L-B WA
50	R Senda X-Treme	'02→'03	YB4L-B WA-N	NB4L-B WA
50	R Senda X-Treme	'05→'20	YB4L-B WA-N	NB4L-B WA
50	Red Bullet	'04→'05	YB4L-B WA-N	NB4L-B WA
50	Senda-R	'96→'02	YB4L-B WA-N	NB4L-B WA
50	SM Senda Classic	'97→'02	YB4L-B WA-N	NB4L-B WA
50	SM Senda Racer	'02→'03	YB4L-B WA-N	NB4L-B WA
50	SM Senda X Race	'04→'11	YB4L-B WA-N	NB4L-B WA
50	SM Senda X-Tr.	'02→'10	YB4L-B WA-N	NB4L-B WA
50	SM Senda X-Tr.	'19→'20	YB4L-B WA-N	NB4L-B WA
50	SM Senda X-Treme Camo	'20	YB4L-B WA-N	NB4L-B WA
50	SM SM1	'00→'01	YB4L-B WA-N	NB4L-B WA
50	Sonar	'10→'11	YB4L-B WA-N	NB4L-B WA
50	Vamos	'93→'95	YB4L-B WA-N	NB4L-B WA
50	Variant Sport	'12	YB4L-B WA-N	NB4L-B WA
125	Cross City	'07→'13	YTX7L-BS-N	NTX7L-BS
125	DRD R Senda	'10→'13	YTX7L-BS-N	NTX7L-BS
125	DRD SM Senda	'09→'14	YTX7L-BS-N	NTX7L-BS
125	DRD SM Senda	'14→'15	YTX7L-BS-N	NTX7L-BS
125	GP1 Racing	'07→'09	YTX7L-BS-N	NTX7L-BS
125	GP1	'06→'09	YTX7L-BS-N	NTX7L-BS
125	GPR 4V	'09→'16	YTX7L-BS-N	NTX7L-BS
125	GPR Nude	'04→'08	YTX5L-BS-N	NTX5L-BS
125	GPR Racing	'04→'09	YTX5L-BS-N	NTX5L-BS
125	Mulhacen	'07→'07	YTX7L-BS-N	NTX7L-BS
125	Mulhacen	'07→'07	YTX7L-BS-N	NTX7L-BS
125	Mulhacen	'08→'10	YTX7L-BS-N	NTX7L-BS
125	Mulhacen Cafe	'08→'11	YTX7L-BS-N	NTX7L-BS
125	R Senda	'04→'05	YTX7L-BS-N	NTX7L-BS
125	R Senda Baja	'06→'12	YTX7L-BS-N	NTX7L-BS
125	Rambla	'08→'12	YTX12-BS-N	NTX12-BS
125	SM Senda	'04→'07	YTX5L-BS-N	NTX5L-BS
125	SM Senda Baja	'06→'12	YTX7L-BS-N	NTX7L-BS

CC	Modello Model	Anno Years	Vecchio Codice Old Code	Nuovo Codice New Code
125	Sonar	'10→'11	YTX12-BS-N	NTX12-BS
125	Terra Adventure	'07→'14	YTX7L-BS-N	NTX7L-BS
125	Terra Euro	'07→'13	YTX7L-BS-N	NTX7L-BS
125	Variant Sport	'12→'12	YB9-B WA-N	NB9-B WA
150	Sonar	'09→'10	YTX12-BS-N	NTX12-BS
300	Rambla I	'10→'12	YTX12-BS-N	NTX12-BS

DUCATI

350	F3	'87→'88	YB14L-A2 WA-N	NB14L-A2 WA
350	Indiana	'87→'88	YB14L-A2 WA-N	NB14L-A2 WA
350	SS	'93→'94	YB16AL-A2 WA-N	NB16AL-A2 WA
400	Monster	'95→'97	YB16AL-A2 WA-N	NB16AL-A2 WA
400	Monster	'02→'04	YT12B-BS-N	NT12B-BS
400	Monster (Japan)	'07→'08	YT12B-BS-N	NT12B-BS
400	Monster Dark	'05	YT12B-BS-N	NT12B-BS
400	Scrambler Sixty 2	'17→'20	YT12B-BS-N	NT12B-BS
400	Supersport	'93→'97	YB16AL-A2 WA-N	NB16AL-A2 WA
500	Pantah	'79→'79	YB14L-A2 WA-N	NB14L-A2 WA
600	Monster	'93→'97	YB16AL-A2 WA-N	NB16AL-A2 WA
600	Monster	'93→'99	YB16AL-A2 WA-N	NB16AL-A2 WA
600	Monster	'00→'01	YT12B-BS-N	NT12B-BS
600	Monster City	'98→'01	YB16AL-A2 WA-N	NB16AL-A2 WA
600	Monster Dark	'98→'01	YB16AL-A2 WA-N	NB16AL-A2 WA
600	Monster Dark City	'98→'01	YB16AL-A2 WA-N	NB16AL-A2 WA
600	Pantah	'81→'82	YB14L-A2 WA-N	NB14L-A2 WA
600	Supersport	'91→'98	YB16AL-A2 WA-N	NB16AL-A2 WA
620	Monster (1a serie)	'02→'05	YT12B-BS-N	NT12B-BS
620	Monster (2a serie)	'05→'06	YT12B-BS-N	NT12B-BS
620	Monster Dark (1a serie)	'03→'05	YT12B-BS-N	NT12B-BS
620	Monster Dark	'05→'06	YT12B-BS-N	NT12B-BS
620	Multistrada	'05→'06	YT12B-BS-N	NT12B-BS
620	Multistrada Dark	'05→'06	YT12B-BS-N	NT12B-BS
620	Supersport S	'03	YT12B-BS-N	NT12B-BS
650	Indiana	'87→'88	YB14L-A2 WA-N	NB14L-A2 WA
650	Pantah	'84→'84	YB14L-A2 WA-N	NB14L-A2 WA
695	Monster	'06→'08	YT12B-BS-N	NT12B-BS
696	Monster	'08→'13	YT12B-BS-N	NT12B-BS
696	Monster +	'09→'14	YT12B-BS-N	NT12B-BS
696	Monster + ABS	'09→'14	YT12B-BS-N	NT12B-BS
696	Monster ABS	'08→'13	YT12B-BS-N	NT12B-BS
696	Monster Anniversary+ABS	'13	YT12B-BS-N	NT12B-BS
748	748	'95→'00	YB16AL-A2 WA-N	NB16AL-A2 WA
748	748	'00→'02	YT12B-BS-N	NT12B-BS
748	748 R	'00→'02	YT12B-BS-N	NT12B-BS
748	748 S	'00→'02	YT12B-BS-N	NT12B-BS
748	748 SP	'95→'99	YB16AL-A2 WA-N	NB16AL-A2 WA
748	748 SPS	'98→'99	YB16AL-A2 WA-N	NB16AL-A2 WA
748	748 Testa Bassa	'01→'01	YT12B-BS-N	NT12B-BS
749	749	'03→'06	YT12B-BS-N	NT12B-BS
749	749 Dark	'05→'06	YT12B-BS-N	NT12B-BS
749	749 R	'03→'07	YT12B-BS-N	NT12B-BS
749	749 S	'03→'07	YT12B-BS-N	NT12B-BS
750	F1	'85→'88	YB14L-A2 WA-N	NB14L-A2 WA
750	F1 Laguna Seca	'87	YB14L-A2 WA-N	NB14L-A2 WA
750	F1 Montjuich	'86	YB14L-A2 WA-N	NB14L-A2 WA
750	F1 Santamonica	'87	YB14L-A2 WA-N	NB14L-A2 WA
750	Indiana	'87→'90	YB14L-A2 WA-N	NB14L-A2 WA
750	Monster (Bidisco)	'96→'00	YB16AL-A2 WA-N	NB16AL-A2 WA
750	Monster (Bidisco)	'01→'02	YT12B-BS-N	NT12B-BS
750	Monster (Monod.)	'96→'97	YB16AL-A2 WA-N	NB16AL-A2 WA

BATTERIE / BATTERY

CC	Modello Model	Anno Years	Vecchio Codice Old Code	Nuovo Codice New Code	CC	Modello Model	Anno Years	Vecchio Codice Old Code	Nuovo Codice New Code
750	Monster City	'99	YB16AL-A2 WA-N	NB16AL-A2 WA	851	851 SP4	'92	YB16AL-A2 WA-N	NB16AL-A2 WA
750	Monster City Dark	'99	YB16AL-A2 WA-N	NB16AL-A2 WA	851	851 Sport	'88-'91	YB16AL-A2 WA-N	NB16AL-A2 WA
750	Monster Dark	'99-'00	YB16AL-A2 WA-N	NB16AL-A2 WA	851	851 Strada	'92-'94	YB16AL-A2 WA-N	NB16AL-A2 WA
750	Monster Dark	'01-'02	YT12B-BS-N	NT12B-BS	860	GT	'75-'76	Y60-N30L-A WA-N	N60-N30L-A WA
750	Paso	'87-'88	YB14L-A2 WA-N	NB14L-A2 WA	860	GTS	'75-'76	Y60-N30L-A WA-N	N60-N30L-A WA
750	Sport	'88-'90	YB16AL-A2 WA-N	NB16AL-A2 WA	888	888 Superbike	'92	YB16AL-A2 WA-N	NB16AL-A2 WA
750	Sport IE	'01-'02	YT12B-BS-N	NT12B-BS	888	888 Superbike Strada SP4	'93-'95	YB16AL-A2 WA-N	NB16AL-A2 WA
750	SS	'91-'99	YB16AL-A2 WA-N	NB16AL-A2 WA	899	Panigale	'14-'15	YT7B-BS-N	NT7B-BS
750	Supersport IE	'99-'00	YB16AL-A2 WA-N	NB16AL-A2 WA	900	Damah SD	'77-'79	Y60-N30L-A WA-N	N60-N30L-A WA
750	Supersport IE	'01-'02	YT12B-BS-N	NT12B-BS	900	GTS	'75-'76	Y60-N30L-A WA-N	N60-N30L-A WA
795	Monster	'12-'15	YT12B-BS-N	NT12B-BS	900	MH IE Evoluzione	'01-'02	YB16AL-A2 WA-N	NB16AL-A2 WA
795	Monster ABS	'13-'15	YT12B-BS-N	NT12B-BS	900	MHR (Mike Hailwood Replica)	'85	YT12B-BS-N	NT12B-BS
795	Monster ABS Corse Stripe	'14-'15	YT12B-BS-N	NT12B-BS	900	Monster	'93-'99	YB16AL-A2 WA-N	NB16AL-A2 WA
796	Hypermotard	'10-'12	YT12B-BS-N	NT12B-BS	900	Monster City	'99	YB16AL-A2 WA-N	NB16AL-A2 WA
796	Monster	'10-'13	YT12B-BS-N	NT12B-BS	900	Monster City Dark	'99	YB16AL-A2 WA-N	NB16AL-A2 WA
796	Monster ABS	'10-'14	YT12B-BS-N	NT12B-BS	900	Monster City Dark IE	'00	YB16AL-A2 WA-N	NB16AL-A2 WA
796	Monster ABS Anniversary	'13	YT12B-BS-N	NT12B-BS	900	Monster City Dark IE	'01-'02	YT12B-BS-N	NT12B-BS
797	Monster	'17-'19	YT12B-BS-N	NT12B-BS	900	Monster City IE	'00	YB16AL-A2 WA-N	NB16AL-A2 WA
797	Monster +	'17-'19	YT12B-BS-N	NT12B-BS	900	Monster City IE	'01-'02	YT12B-BS-N	NT12B-BS
800	Monster	'03-'04	YT12B-BS-N	NT12B-BS	900	Monster Cromo	'98	YB16AL-A2 WA-N	NB16AL-A2 WA
800	Monster Dark	'03	YT12B-BS-N	NT12B-BS	900	Monster Cromo IE	'00	YB16AL-A2 WA-N	NB16AL-A2 WA
800	Monster S	'03-'04	YT12B-BS-N	NT12B-BS	900	Monster Cromo IE	'01-'02	YT12B-BS-N	NT12B-BS
800	Monster S2R	'05-'07	YT12B-BS-N	NT12B-BS	900	Monster Dark	'99	YB16AL-A2 WA-N	NB16AL-A2 WA
800	Monster S2R Dark	'05-'06	YT12B-BS-N	NT12B-BS	900	Monster Dark	'99	YB16AL-A2 WA-N	NB16AL-A2 WA
800	Supersport	'03-'05	YT12B-BS-N	NT12B-BS	900	Monster Dark IE	'00	YB16AL-A2 WA-N	NB16AL-A2 WA
800	Supersport S	'03	YT12B-BS-N	NT12B-BS	900	Monster Dark IE	'01-'02	YT12B-BS-N	NT12B-BS
803	Scrambler Cafe' Racer	'17-'20	YT12B-BS-N	NT12B-BS	900	Monster IE	'99-'00	YB16AL-A2 WA-N	NB16AL-A2 WA
803	Scrambler Classic	'15-'18	YT12B-BS-N	NT12B-BS	900	Monster IE	'01-'02	YT12B-BS-N	NT12B-BS
803	Scrambler Desert Sled	'17-'20	YT12B-BS-N	NT12B-BS	900	Monster Met. IE	'00-'01	YB16AL-A2 WA-N	NB16AL-A2 WA
803	Scrambler Flat Track PRO	'16-'16	YT12B-BS-N	NT12B-BS	900	Monster S	'98-'99	YB16AL-A2 WA-N	NB16AL-A2 WA
803	Scrambler Full Throttle	'15-'20	YT12B-BS-N	NT12B-BS	900	Monster S IE	'00	YB16AL-A2 WA-N	NB16AL-A2 WA
803	Scrambler Icon	'15-'20	YT12B-BS-N	NT12B-BS	900	Monster S IE	'00-'02	YT12B-BS-N	NT12B-BS
803	Scrambler Icon Dark	'20	YT12B-BS-N	NT12B-BS	900	Sport IE	2002	YT12B-BS-N	NT12B-BS
803	Scrambler Mach 2.0	'18	YT12B-BS-N	NT12B-BS	900	SS Super Light	'92-'96	YB16AL-A2 WA-N	NB16AL-A2 WA
803	Scrambler SCR	'20	YT12B-BS-N	NT12B-BS	900	Supersport	'89-'97	YB16AL-A2 WA-N	NB16AL-A2 WA
803	Scrambler Street Classic	'18	YT12B-BS-N	NT12B-BS	900	Supersport FE	'97-'98	YB16AL-A2 WA-N	NB16AL-A2 WA
803	Scrambler Urban Enduro	'15-'16	YT12B-BS-N	NT12B-BS	900	Supersport IE	'98-'00	YB16AL-A2 WA-N	NB16AL-A2 WA
821	Hypermotard	'13-'15	YT12B-BS-N	NT12B-BS	900	Supersport IE	'01-'02	YT12B-BS-N	NT12B-BS
821	Hypermotard SP	'13-'15	YT12B-BS-N	NT12B-BS	906	Paso	'88-'91	YB14L-A2 WA-N	NB14L-A2 WA
821	Hyperstrada	'13-'15	YT12B-BS-N	NT12B-BS	916	916	'94-'98	YB16AL-A2 WA-N	NB16AL-A2 WA
821	Monster	'14-'20	YT12B-BS-N	NT12B-BS	916	916 S	'94-'94	YB16AL-A2 WA-N	NB16AL-A2 WA
821	Monster Dark	'15-'18	YT12B-BS-N	NT12B-BS	916	916 Senna	'95-'98	YB16AL-A2 WA-N	NB16AL-A2 WA
821	Monster Stealth	'19-'20	YT12B-BS-N	NT12B-BS	916	916 SP	'94-'95	YB16AL-A2 WA-N	NB16AL-A2 WA
821	Monster Stripe	'15-'18	YT12B-BS-N	NT12B-BS	916	916 SP III	'96	YB16AL-A2 WA-N	NB16AL-A2 WA
848	848	'07-'13	YT12B-BS-N	NT12B-BS	916	Monster S4	'01-'03	YT12B-BS-N	NT12B-BS
848	848 EVO	'10-'13	YT12B-BS-N	NT12B-BS	916	Monster S4 Foggy	'02	YT12B-BS-N	NT12B-BS
848	848 EVO Corse Special Edition	'11-'13	YT12B-BS-N	NT12B-BS	916	ST4	'99-'00	YB16AL-A2 WA-N	NB16AL-A2 WA
848	Streetfighter	'11-'15	YT12B-BS-N	NT12B-BS	916	ST4	'01-'03	YT12B-BS-N	NT12B-BS
851	851 SP1	'88-'89	YB16AL-A2 WA-N	NB16AL-A2 WA	939	Hypermotard	'16-'18	YT12B-BS-N	NT12B-BS
851	851 SP2	'90-'90	YB16AL-A2 WA-N	NB16AL-A2 WA	939	Hypermotard SP	'16-'18	YT12B-BS-N	NT12B-BS
851	851 SP3	'91-'91	YB16AL-A2 WA-N	NB16AL-A2 WA	939	Hyperstrada	'16-'18	YT12B-BS-N	NT12B-BS
					939	Supersport	'17-'19	YT12B-BS-N	NT12B-BS
					939	Supersport S	'17-'19	YT12B-BS-N	NT12B-BS
					944	ST2	'97-'00	YB16AL-A2 WA-N	NB16AL-A2 WA
					944	ST2	'01-'03	YT12B-BS-N	NT12B-BS
					950	Hypermotard	'19-'20	YT12B-BS-N	NT12B-BS
					950	Hypermotard SP	'19-'20	YT12B-BS-N	NT12B-BS

BATTERIE / BATTERY

CC	Modello Model	Anno Years	Vecchio Codice Old Code	Nuovo Codice New Code	CC	Modello Model	Anno Years	Vecchio Codice Old Code	Nuovo Codice New Code
950	Multistrada	'17→'20	YT12B-BS-N	NT12B-BS	1100	Scrambler Special	'18→'20	YT12B-BS-N	NT12B-BS
950	Multistrada S	'19→'20	YT12B-BS-N	NT12B-BS	1100	Scrambler Sport	'18→'20	YT12B-BS-N	NT12B-BS
955	Panigale V2	'20	YT7B-BS-N	NT7B-BS	1100	Scram. Sport Pro	'20	YT12B-BS-N	NT12B-BS
959	Panigale	'16→'19	YT7B-BS-N	NT7B-BS	1100	Streetfighter	'09→'11	YT12B-BS-N	NT12B-BS
959	Panigale Corse	'18→'19	YT7B-BS-N	NT7B-BS	1100	Streetfighter S	'09→'13	YT12B-BS-N	NT12B-BS
990	Desmodesici RR	'07→'09	YT12B-BS-N	NT12B-BS	1103	Panigale V4	'18→'20	YT7B-BS-N	NT7B-BS
992	ST3	'04→'07	YT12B-BS-N	NT12B-BS	1103	Panigale V4 S	'18→'20	YT7B-BS-N	NT7B-BS
992	ST3 ABS	'06→'07	YT12B-BS-N	NT12B-BS	1103	Panigale V4 S Corse	'19	YT7B-BS-N	NT7B-BS
992	ST3 S ABS	'06→'07	YT12B-BS-N	NT12B-BS	1103	Panigale V4 Speciale	'18→'19	YT7B-BS-N	NT7B-BS
996	996	'99→'00	YB16AL-A2 WA-N	NB16AL-A2 WA	1103	Streetfighter V4	'20	YT7B-BS-N	NT7B-BS
996	996	'01→'01	YT12B-BS-N	NT12B-BS	1103	Streetfighter V4 S	'20	YT7B-BS-N	NT7B-BS
996	916 SPS	'97→'98	YB16AL-A2 WA-N	NB16AL-A2 WA	1198	1198	'09→'12	YT12B-BS-N	NT12B-BS
996	996 S	'01→'01	YT12B-BS-N	NT12B-BS	1198	1098 R	'07→'11	YT12B-BS-N	NT12B-BS
996	996 SPS	'99→'00	YB16AL-A2 WA-N	NB16AL-A2 WA	1198	1098 R Bayliss	'09→'11	YT12B-BS-N	NT12B-BS
996	Monster S4R	'03→'06	YT12B-BS-N	NT12B-BS	1198	1198 R Corse Special Edition	'10→'12	YT12B-BS-N	NT12B-BS
996	ST4 S	'01→'05	YT12B-BS-N	NT12B-BS	1198	1198 S	'08→'12	YT12B-BS-N	NT12B-BS
998	998	'02→'03	YT12B-BS-N	NT12B-BS	1198	1198 S Corse Special Edition	'10→'12	YT12B-BS-N	NT12B-BS
998	996 R	'01	YT12B-BS-N	NT12B-BS	1198	1198 SP	'11→'12	YT12B-BS-N	NT12B-BS
998	998 Matrix	'03→'04	YT12B-BS-N	NT12B-BS	1199	Panigale	'12→'13	YT7B-BS-N	NT7B-BS
998	998 R	'02	YT12B-BS-N	NT12B-BS	1199	Panigale ABS	'13→'14	YT7B-BS-N	NT7B-BS
998	998 S	'02→'04	YT12B-BS-N	NT12B-BS	1199	Panigale R	'13→'17	YT7B-BS-N	NT7B-BS
998	998 S Bayliss/ Bostrom	'02	YT12B-BS-N	NT12B-BS	1199	Panigale S	'13→'14	YT7B-BS-N	NT7B-BS
998	Monster S4R Testastretta	'07→'08	YT12B-BS-N	NT12B-BS	1199	Panigale S ABS	'13→'14	YT7B-BS-N	NT7B-BS
998	Monster S4RS Testastretta	'06→'08	YT12B-BS-N	NT12B-BS	1199	Panigale S Tricolore	'12→'14	YT7B-BS-N	NT7B-BS
999	999	'03→'06	YT12B-BS-N	NT12B-BS	1200	Diavel	'11→'18	YT12B-BS-N	NT12B-BS
999	999 R	'03→'06	YT12B-BS-N	NT12B-BS	1200	Diavel AMG	'12→'13	YT12B-BS-N	NT12B-BS
999	999 R Xerox	'06→'06	YT12B-BS-N	NT12B-BS	1200	Diavel Carbon	'11→'18	YT12B-BS-N	NT12B-BS
999	999 S	'03→'06	YT12B-BS-N	NT12B-BS	1200	Diavel Cromo	'12→'12	YT12B-BS-N	NT12B-BS
1000	Monster	'03→'05	YT12B-BS-N	NT12B-BS	1200	Diavel Dark	'12→'13	YT12B-BS-N	NT12B-BS
1000	Monster S	'03→'05	YT12B-BS-N	NT12B-BS	1200	Diavel Diesel	'17→'18	YT12B-BS-N	NT12B-BS
1000	Monster S2R	'06→'08	YT12B-BS-N	NT12B-BS	1200	diavel strada	'13→'14	YT12B-BS-N	NT12B-BS
1000	Multistrada DS '03	'06	YT12B-BS-N	NT12B-BS	1200	Diavel Titanium	'15	YT12B-BS-N	NT12B-BS
1000	Multistrada S DS	'03→'06	YT12B-BS-N	NT12B-BS	1200	Monster	'14→'20	YT12B-BS-N	NT12B-BS
1000	Paul Smart LE	'06→'08	YT12B-BS-N	NT12B-BS	1200	Monster 25° An.	'19	YT12B-BS-N	NT12B-BS
1000	Sportclassic	'06→'08	YT12B-BS-N	NT12B-BS	1200	Monster R	'16→'19	YT12B-BS-N	NT12B-BS
1000	Sportclassic GT	'06→'12	YT12B-BS-N	NT12B-BS	1200	Monster S	'14→'20	YT12B-BS-N	NT12B-BS
1000	Sportclassic GT Touring	'06→'12	YT12B-BS-N	NT12B-BS	1200	Monster S Stripe	'15→'16	YT12B-BS-N	NT12B-BS
1000	Sportclassic S	'06→'11	YT12B-BS-N	NT12B-BS	1200	Multistrada	'10→'12	YT12B-BS-N	NT12B-BS
1000	Supersport	'03→'06	YT12B-BS-N	NT12B-BS	1200	Multistrada ABS	'10→'17	YT12B-BS-N	NT12B-BS
1000	Supersport DS	'04→'06	YT12B-BS-N	NT12B-BS	1200	Multistrada Enduro	'16→'18	YT12B-BS-N	NT12B-BS
1098	1098	'06→'09	YT12B-BS-N	NT12B-BS	1200	Mult. Enduro Pro	'17→'19	YT12B-BS-N	NT12B-BS
1098	1098 S	'06→'11	YT12B-BS-N	NT12B-BS	1200	Multistrada Enduro Touring	'16→'18	YT12B-BS-N	NT12B-BS
1098	1098 S Tricolore	'07	YT12B-BS-N	NT12B-BS	1200	Multistrada Pikes Peak	'16→'17	YT12B-BS-N	NT12B-BS
1100	Hypermotard	'07→'09	YT12B-BS-N	NT12B-BS	1200	Multistrada S	'15→'17	YT12B-BS-N	NT12B-BS
1100	Hyperm. EVO	'10→'12	YT12B-BS-N	NT12B-BS	1200	Mult. S D-AIR	'15→'17	YT12B-BS-N	NT12B-BS
1100	Hyperm. EVO SP	'10→'12	YT12B-BS-N	NT12B-BS	1200	Multistrada S Granturismo	'13→'14	YT12B-BS-N	NT12B-BS
1100	Hypermotard S	'07→'09	YT12B-BS-N	NT12B-BS	1200	Multistrada S Pikes Peak	'12→'14	YT12B-BS-N	NT12B-BS
1100	Monster	'09→'10	YT12B-BS-N	NT12B-BS	1200	Mult. S Sport	'10→'12	YT12B-BS-N	NT12B-BS
1100	Monster ABS	'10	YT12B-BS-N	NT12B-BS	1200	Mult. S Touring	'10→'14	YT12B-BS-N	NT12B-BS
1100	Monster Diesel	'13	YT12B-BS-N	NT12B-BS	1200	Multistrada S Touring D-Air	'14	YT12B-BS-N	NT12B-BS
1100	Mon. EVO ABS	'11→'13	YT12B-BS-N	NT12B-BS	1260	Diavel	'19→'20	YT12B-BS-N	NT12B-BS
1100	Monster EVO Anniversary	'13	YT12B-BS-N	NT12B-BS	1260	Diavel S	'19→'20	YT12B-BS-N	NT12B-BS
1100	Monster S	'09→'10	YT12B-BS-N	NT12B-BS					
1100	Monster S ABS	'10	YT12B-BS-N	NT12B-BS					
1100	Multistrada	'07→'09	YT12B-BS-N	NT12B-BS					
1100	Multistrada S	'07→'09	YT12B-BS-N	NT12B-BS					
1100	Scrambler	'18→'20	YT12B-BS-N	NT12B-BS					

BATTERIE / BATTERY

CC	Modello Model	Anno Years	Vecchio Codice Old Code	Nuovo Codice New Code
1260	Multistrada	'18→'20	YT12B-BS-N	NT12B-BS
1260	Multistrada Enduro	'19→'20	YT12B-BS-N	NT12B-BS
1260	Multistrada S	'18→'20	YT12B-BS-N	NT12B-BS
1260	Mult. S D-AIR	'18→'20	YT12B-BS-N	NT12B-BS
1260	Multistrada S Grand Tour	'20	YT12B-BS-N	NT12B-BS
1260	Multistrada S Pikes Peak	'18→'20	YT12B-BS-N	NT12B-BS
1262	XDiavel	'16→'20	YT12B-BS-N	NT12B-BS
1262	XDiavel S	'16→'20	YT12B-BS-N	NT12B-BS
1299	Panigale	'15→'17	YT7B-BS-N	NT7B-BS
1299	Panigale R Final Edition	'17→'18	YT7B-BS-N	NT7B-BS
1299	Panigale S	'15→'17	YT7B-BS-N	NT7B-BS
1299	Panigale S Anniv.	'16→'17	YT7B-BS-N	NT7B-BS
1299	Superleggera	'17→'17	YT7B-BS-N	NT7B-BS

E-TON

50	BXL Draco	'05→'06	YTX5L-BS-N	NTX5L-BS
50	RXL M Viper Mini	'04→'07	YTX5L-BS-N	NTX5L-BS
50	RXL Viper	'04→'07	YTX5L-BS-N	NTX5L-BS
90	RXL R Viper	'04→'07	YTX5L-BS-N	NTX5L-BS
90	RXL Viper	'04→'07	YTX5L-BS-N	NTX5L-BS
150	CXL Challenger	'02→'03	YTX9-BS-N	NTX9-BS
150	YXL Yukon	'00→'02	YTX9-BS-N	NTX9-BS

FANTIC MOTOR

50	Caballero Regularita Comp.	'12→'15	YT4L-BS-N	NT4L-BS
50	Caballero Regularita Scud.	'12→'15	YT4L-BS-N	NT4L-BS
50	Koala	'88→'95	YB4L-B WA-N	NB4L-B WA
50	TX E Regularita Casa E	'12→'15	YT4L-BS-N	NT4L-BS
50	TX M Mot. Casa M	'12→'15	YT4L-BS-N	NT4L-BS
50	TX MR Motard Competizione MR	'12→'15	YT4L-BS-N	NT4L-BS
80	Koala	'93→'96	YB4L-B WA-N	NB4L-B WA

GARELLI

50	Sahel	'91	YB4L-B WA-N	NB4L-B WA
50	Tiger XLE	'86	YB4L-B WA-N	NB4L-B WA
125	Tiger XLE	'86	YB9-B WA-N	NB9-B WA
125	Tiger XR	'83	YB5L-B WA-N	NB5L-B WA

GAS GAS

50	EC	'05→'07	YB4L-B WA-N	NB4L-B WA
50	EC Rookie	'01→'05	YB4L-B WA-N	NB4L-B WA
50	SM	'05	YB4L-B WA-N	NB4L-B WA
50	SM Rookie	'01→'05	YB4L-B WA-N	NB4L-B WA
200	EC	'13→'17	YTZ7S-BS-N	NTZ7S-BS
200	EC ER	'14→'17	YTZ7S-BS-N	NTZ7S-BS
250	EC	'12→'17	YTZ7S-BS-N	NTZ7S-BS
250	EC ER	'14→'15	YTZ7S-BS-N	NTZ7S-BS
250	EC ER	'17	YTZ7S-BS-N	NTZ7S-BS
250	EC F	'10→'15	YTZ7S-BS-N	NTZ7S-BS
250	EC F Cami	'14→'15	YTZ7S-BS-N	NTZ7S-BS
300	EC	'12→'15	YTZ7S-BS-N	NTZ7S-BS
300	EC ER	'14→'17	YTZ7S-BS-N	NTZ7S-BS
300	EC F	'13→'15	YTZ7S-BS-N	NTZ7S-BS
400	EC FSE	'02	YTZ7S-BS-N	NTZ7S-BS

CC	Modello Model	Anno Years	Vecchio Codice Old Code	Nuovo Codice New Code
400	SM FSE	'01→'02	YTZ7S-BS-N	NTZ7S-BS
450	EC F	'13→'15	YTZ7S-BS-N	NTZ7S-BS
450	EC FSE Enduro	'03→'09	YTZ7S-BS-N	NTZ7S-BS
450	EC FSR	'05→'09	YTZ7S-BS-N	NTZ7S-BS
450	HP Wild Quad	'04→'09	YTZ7S-BS-N	NTZ7S-BS
450	SM FSE SuperM.	'03→'09	YTZ7S-BS-N	NTZ7S-BS
515	EC FSE	'05→'09	YTZ7S-BS-N	NTZ7S-BS
515	EC FSR	'05→'09	YTZ7S-BS-N	NTZ7S-BS
515	HP Wild Quad	'09	YTZ7S-BS-N	NTZ7S-BS
515	SM FSR	'07→'09	YTZ7S-BS-N	NTZ7S-BS

GENERIC

50	SM Trigger	'06→'13	YB4L-B WA-N	NB4L-B WA
50	SM Trigger Comp.	'08→'11	YB4L-B WA-N	NB4L-B WA
50	X Trigger	'06→'13	YB4L-B WA-N	NB4L-B WA

GILERA

50	Bullit	'90	YB4L-B WA-N	NB4L-B WA
50	DNA	'01→'06	YT4L-BS-N	NT4L-BS
50	Eaglet	'96→'98	YB4L-B WA-N	NB4L-B WA
50	Easy Moving	'95→'96	YB4L-B WA-N	NB4L-B WA
50	GP	'02→'03	YB4L-B WA-N	NB4L-B WA
50	GSA Vale	'00	YB4L-B WA-N	NB4L-B WA
50	GSM	'00→'03	YB4L-B WA-N	NB4L-B WA
50	H@K	'00→'02	YB4L-B WA-N	NB4L-B WA
50	ICE	'00→'02	YT4L-BS-N	NT4L-BS
50	RC Top Rally	'90	YB4L-B WA-N	NB4L-B WA
50	RCR Enduro	'06→'20	YB4L-B WA-N	NB4L-B WA
50	Runner	'02→'05	YB9-B WA-N	NB9-B WA
50	Runner DD	'02→'05	YB9-B WA-N	NB9-B WA
50	Runner Pure Jet	'04→'14	YB9-B WA-N	NB9-B WA
50	Run. Pure Jet Race	'05→'06	YB9-B WA-N	NB9-B WA
50	Run. Pure Jet SC	'05→'06	YB9-B WA-N	NB9-B WA
50	Run. Pure Jet ST	'08	YB9-B WA-N	NB9-B WA
50	Runner Purejet	'02→'14	YB9-B WA-N	NB9-B WA
50	Runner SP	'15→'17	YB9-B WA-N	NB9-B WA
50	Runner SP Race	'05	YB9-B WA-N	NB9-B WA
50	Runner SP SC	'06	YB9-B WA-N	NB9-B WA
50	SMT Supermotard	'03→'20	YB4L-B WA-N	NB4L-B WA
50	SMT SuperM. Drifting	'19→'20	YB4L-B WA-N	NB4L-B WA
50	Stalker	'97→'11	YB4L-B WA-N	NB4L-B WA
50	Storm	'07	YB9-B WA-N	NB9-B WA
50	Typhoon	'93→'96	YB4L-B WA-N	NB4L-B WA
50	Typhoon Benetton	'93→'96	YB4L-B WA-N	NB4L-B WA
50	Typhoon Martini	'93→'96	YB4L-B WA-N	NB4L-B WA
50	Typhoon XR	'93→'96	YB4L-B WA-N	NB4L-B WA
50	Zulu	'01→'02	YB4L-B WA-N	NB4L-B WA
125	Coguar	'99→'02	YB9-B WA-N	NB9-B WA
125	Nexus	'07→'08	YTX12-BS-N	NTX12-BS
125	Nexus IE	'08→'11	YTX14-BS-N	NTX14-BS
125	Runner FX	'99→'02	YB9-B WA-N	NB9-B WA
125	Runner FXR	'99→'02	YB9-B WA-N	NB9-B WA
125	Runner SP	'99→'02	YB9-B WA-N	NB9-B WA
125	Runner VX	'01→'06	YB9-B WA-N	NB9-B WA
125	Runner VX	'07	YTX12-BS-N	NTX12-BS
125	Runner VX ST	'08→'13	YTX12-BS-N	NTX12-BS
125	RV	'88	YB9-B WA-N	NB9-B WA
125	XR1	'89	YB9-B WA-N	NB9-B WA
125	XR2	'90→'93	YB9-B WA-N	NB9-B WA
180	Runner VXR	'01→'04	YT12B-BS-N	NT12B-BS

BATTERIE / BATTERY

CC	Modello Model	Anno Years	Vecchio Codice Old Code	Nuovo Codice New Code	CC	Modello Model	Anno Years	Vecchio Codice Old Code	Nuovo Codice New Code
200	Runner VXR	'05→'06	YTX12-BS-N	NTX12-BS	100	SJ Bali	'96→'99	YTX5L-BS-N	NTX5L-BS
200	RV ES	'87	YB9-B WA-N	NB9-B WA	100	SJ Bali EX	'96→'01	YTX5L-BS-N	NTX5L-BS
250	Nexus IE	'07	YTX14-BS-N	NTX14-BS	110	AFS Wave	'12→'16	YT4L-BS-N	NT4L-BS
300	Nexus IE	'08	YTX14-BS-N	NTX14-BS	110	CRF F	'13→'19	YT4L-BS-N	NT4L-BS
300	Nexus IE	'09→'12	YTX12-BS-N	NTX12-BS	110	CT P	'93	YT4L-BS-N	NT4L-BS
350	XRT	'90	YB14L-A2 WA-N	NB14L-A2 WA	110	NSC Lead	'11→'13	YTX7L-BS-N	NTX7L-BS
500	Fuoco IE LT	'13→'15	YTX14-BS-N	NTX14-BS	110	NSC Vision	'12→'18	YTX7L-BS-N	NTX7L-BS
500	Nexus	'03→'08	YB14L-A2 WA-N	NB14L-A2 WA	110	SCV Lead	'08→'13	YTX7L-BS-N	NTX7L-BS
600	RC	'89→'90	YB14L-A2 WA-N	NB14L-A2 WA	125	@ NES	'00→'06	YTX7L-BS-N	NTX7L-BS
600	XRT	'88→'89	YB14L-A2 WA-N	NB14L-A2 WA	125	ANF Innova	'03→'11	YTZ7S-BS-N	NTZ7S-BS
800	GP	'08→'14	YTX14-BS-N	NTX14-BS	125	ANF Supra X	'11→'12	YTZ7S-BS-N	NTZ7S-BS
					125	ANF Wave	'11→'12	YTZ7S-BS-N	NTZ7S-BS
					125	ATC M	'86	YTX12-BS-N	NTX12-BS
					125	CA Rebel	'95→'00	YTX7L-BS-N	NTX7L-BS
					125	CB F (GLR)	'15→'20	YTX7L-BS-N	NTX7L-BS
					125	CB TD	'82→'88	YB9-B WA-N	NB9-B WA
					125	CBF M	'09→'16	YTX7L-BS-N	NTX7L-BS
					125	CBR R	'04→'06	YTZ7S-BS-N	NTZ7S-BS
					125	CBR RW	'05→'10	YTZ7S-BS-N	NTZ7S-BS
					125	CG	'77→'84	YT4L-BS-N	NT4L-BS
					125	CG	'98→'03	YT4L-BS-N	NT4L-BS
					125	CG BR	'85→'97	YT4L-BS-N	NT4L-BS
					125	CG Cargo	'09→'10	YT4L-BS-N	NT4L-BS
					125	CG ES	'04→'08	YTX5L-BS-N	NTX5L-BS
					125	CG Job	'05→'05	YT4L-BS-N	NT4L-BS
					125	CH Spacy	'83→'86	YB9-B WA-N	NB9-B WA
					125	CH Spacy	'88→'96	YTX9-BS-N	NTX9-BS
					125	CH Spacy	'96→'01	YTZ12S-BS-N	NTZ12S-BS
					125	CLR W City Fly	'98→'03	YTX5L-BS-N	NTX5L-BS
					125	CM C	'82→'85	YB9-B WA-N	NB9-B WA
					125	CM T	'81→'82	YB9-B WA-N	NB9-B WA
					125	CRFF (Small Wh.)	'14→'19	YT4L-BS-N	NT4L-BS
					125	CRF FB (Big Wh.)	'14→'19	YT4L-BS-N	NT4L-BS
					125	CRM R	'90→'99	YT4L-BS-N	NT4L-BS
					125	Dylan	'02→'07	YTX7L-BS-N	NTX7L-BS
					125	MBX F	'84→'86	YB5L-B WA-N	NB5L-B WA
					125	MTX R	'86→'95	YB5L-B WA-N	NB5L-B WA
					125	NH Lead	'86→'87	YB5L-B WA-N	NB5L-B WA
					125	NH MD Lead	'83	YB5L-B WA-N	NB5L-B WA
					125	NS F	'86→'87	YB5L-B WA-N	NB5L-B WA
					125	NS R	'87	YB5L-B WA-N	NB5L-B WA
					125	NSR F	'88→'92	YTX5L-BS-N	NTX5L-BS
					125	NSR R	'89→'01	YTX5L-BS-N	NTX5L-BS
					125	NX Transcity	'89→'97	YTX7L-BS-N	NTX7L-BS
					125	NXR Bros	'05→'05	YTX5L-BS-N	NTX5L-BS
					125	Pantheon (FES)	'98→'02	YTX9-BS-N	NTX9-BS
					125	Pantheon (FES)	'03→'06	YTX7L-BS-N	NTX7L-BS
					125	PCX	'10→'18	YTZ7S-BS-N	NTZ7S-BS
					125	PCX ABS	'18→'20	YTZ7S-BS-N	NTZ7S-BS
					125	PS I (PES)	'06→'13	YTX7L-BS-N	NTX7L-BS
					125	SH	'00→'04	YTX7L-BS-N	NTX7L-BS
					125	SH i	'05→'12	YTX7L-BS-N	NTX7L-BS
					125	SH i	'13→'20	YTZ7S-BS-N	NTZ7S-BS
					125	SH i (Tam. Post.)	'09→'12	YTX7L-BS-N	NTX7L-BS
					125	SH i ABS	'13→'16	YTZ7S-BS-N	NTZ7S-BS
					125	SH i GT	'09→'12	YTX7L-BS-N	NTX7L-BS
					125	SH i Mode	'13→'16	YTZ7S-BS-N	NTZ7S-BS
					125	SH i Special	'05→'08	YTX7L-BS-N	NTX7L-BS
					125	SH i Sport	'05→'08	YTX7L-BS-N	NTX7L-BS
					125	S-Wing (FES)	'07→'13	YTX7L-BS-N	NTX7L-BS
					125	S-Wing ABS (FES A)	'07→'15	YTX7L-BS-N	NTX7L-BS

HONDA

50	C	'92→'93	YB4L-B WA-N	NB4L-B WA
50	C	'95→'95	YB4L-B WA-N	NB4L-B WA
50	C	'97	YB4L-B WA-N	NB4L-B WA
50	C	'99→'02	YB4L-B WA-N	NB4L-B WA
50	CHF Scoopy	'01→'05	YTZ7S-BS-N	NTZ7S-BS
50	CHF scoopy	'06→'09	YTZ7S-BS-N	NTZ7S-BS
50	NH SS Lead	'84→'84	YB4L-B WA-N	NB4L-B WA
50	NJ M Gyro-X	'02	YTX7L-BS-N	NTX7L-BS
50	NJ MD Gyro-X	'00	YTX7L-BS-N	NTX7L-BS
50	NJ MD Gyro-X	'02	YTX7L-BS-N	NTX7L-BS
50	NPC Bite	'02→'03	YTZ7S-BS-N	NTZ7S-BS
50	NPS Zoomer	'01→'14	YTZ7S-BS-N	NTZ7S-BS
50	NSC MPD Vision	'12→'18	YTX7L-BS-N	NTX7L-BS
50	NSC R Vision	'12→'17	YTX7L-BS-N	NTX7L-BS
50	NSC WH Vision	'12→'16	YTX7L-BS-N	NTX7L-BS
50	NSR	'87→'89	YB4L-B WA-N	NB4L-B WA
50	NSR	'97	YB4L-B WA-N	NB4L-B WA
50	NSR	'99	YB4L-B WA-N	NB4L-B WA
50	NSR F	'93→'95	YB4L-B WA-N	NB4L-B WA
50	NSR R	'97→'00	YB4L-B WA-N	NB4L-B WA
50	NSR S	'89→'95	YB4L-B WA-N	NB4L-B WA
50	NU M Runaway	'82	YB4L-B WA-N	NB4L-B WA
50	NX Caren	'80→'81	YB4L-B WA-N	NB4L-B WA
50	NX M Caren	'81	YB4L-B WA-N	NB4L-B WA
50	PK Wallaroo	'90→'01	YT4L-BS-N	NT4L-BS
50	PX	'82→'84	YB4L-B WA-N	NB4L-B WA
50	PXR	'84	YB4L-B WA-N	NB4L-B WA
50	SA Vision	'88→'95	YT4L-BS-N	NT4L-BS
50	SGX SKY	'97→'03	YT4L-BS-N	NT4L-BS
50	SH	'01→'03	YTZ7S-BS-N	NTZ7S-BS
50	SRX Shadow	'96→'99	YT4L-BS-N	NT4L-BS
50	SRX Shadow	'96→'99	YT4L-BS-N	NT4L-BS
50	ST	'88→'93	YT4L-BS-N	NT4L-BS
50	Tact	'85	YTZ7S-BS-N	NTZ7S-BS
50	TC Gyro Canopy	'00→'02	YTX7L-BS-N	NTX7L-BS
50	ZB	'87	YT4L-BS-N	NT4L-BS
70	ST Dax	'89→'01	YT4L-BS-N	NT4L-BS
75	SA Vision	'89	YT4L-BS-N	NT4L-BS
75	SH	'87→'95	YB5L-B WA-N	NB5L-B WA
80	NH MD	'83→'86	YB5L-B WA-N	NB5L-B WA
80	NH MD	'94	YB5L-B WA-N	NB5L-B WA
90	EZ CUB	'91→'95	YTX5L-BS-N	NTX5L-BS
90	TRX EX	'07→'08	YTX5L-BS-N	NTX5L-BS
90	TRX Fourtrax	'06	YTX5L-BS-N	NTX5L-BS
90	TRX X	'09	YTX5L-BS-N	NTX5L-BS
90	TRX X	'12→'15	YTX5L-BS-N	NTX5L-BS
100	NF Astrea	'97→'99	YTX5L-BS-N	NTX5L-BS
100	SCV Lead	'03→'08	YTX5L-BS-N	NTX5L-BS
100	SH	'96→'01	YTX5L-BS-N	NTX5L-BS

BATTERIE / BATTERY

CC	Modello Model	Anno Years	Vecchio Codice Old Code	Nuovo Codice New Code	CC	Modello Model	Anno Years	Vecchio Codice Old Code	Nuovo Codice New Code
125	TRX	'88	YTX9-BS-N	NTX9-BS	250	CMX C Rebel	'96→'00	YTX7L-BS-N	NTX7L-BS
125	VT C Shadow	'99→'00	YTX7L-BS-N	NTX7L-BS	250	CN Fusion	'03	YTX12-BS-N	NTX12-BS
125	VT C Shadow	'01→'03	YTZ7S-BS-N	NTZ7S-BS	250	CN Helix	'87→'98	YTX12-BS-N	NTX12-BS
125	VT C Shadow	'04→'08	YTX7L-BS-N	NTX7L-BS	250	CN Spazio	'87→'99	YTX12-BS-N	NTX12-BS
125	XL Paris Dakar	'85→'87	YB9-B WA-N	NB9-B WA	250	CRF L	'12→'15	YTX7L-BS-N	NTX7L-BS
125	XL R	'82→'97	YB9-B WA-N	NB9-B WA	250	CRF M	'13→'16	YTX7L-BS-N	NTX7L-BS
125	XL V Varadero	'00→'16	YTZ7S-BS-N	NTZ7S-BS	250	CRF X	'04→'18	YTX5L-BS-N	NTX5L-BS
125	XLR R	'97→'01	YTX7A-BS-N	NTX7A-BS	250	Foresight (FES)	'98→'99	YTX12-BS-N	NTX12-BS
125	XR L	'03→'08	YTX5L-BS-N	NTX5L-BS	250	Foresight (FES)	'01→'05	YTZ12S-BS-N	NTZ12S-BS
150	@ NES	'01→'06	YTX7L-BS-N	NTX7L-BS	250	Forza (NSS A)	'00→'01	YTZ12S-BS-N	NTZ12S-BS
150	CBF	'11→'12	YTX7L-BS-N	NTX7L-BS	250	Forza (NSS A)	'03	YTZ12S-BS-N	NTZ12S-BS
150	CG ES Titan	'04→'05	YTX7L-BS-N	NTX7L-BS	250	Forza ABS (NSS A)	'08→'11	YTZ12S-BS-N	NTZ12S-BS
150	CG ESD Titan	'04→'05	YTX7L-BS-N	NTX7L-BS	250	Forza ABS (NSS A)	'08→'11	YTZ12S-BS-N	NTZ12S-BS
150	CRF F	'06→'16	YTX5L-BS-N	NTX5L-BS	250	Forza ABS (NSS AX)	'05→'06	YTZ12S-BS-N	NTZ12S-BS
150	Dylan	'02→'06	YTX7L-BS-N	NTX7L-BS	250	Forza ABS (NSS EX)	'05→'08	YTZ12S-BS-N	NTZ12S-BS
150	Panth. (FES) 2T	'98→'02	YTX9-BS-N	NTX9-BS	250	GB Clubman	'84→'94	YB9-B WA-N	NB9-B WA
150	Panth. (FES) 2T	'03	YTX7L-BS-N	NTX7L-BS	250	GB Clubman	'95→'97	YTX9-BS-N	NTX9-BS
150	Panth. (FES) 4T	'04→'06	YTX7L-BS-N	NTX7L-BS	250	Jazz (NSS)	'00→'07	YTZ12S-BS-N	NTZ12S-BS
150	PCX	'10→'14	YTZ7S-BS-N	NTZ7S-BS	250	Jazz ABS (NSS)	'03→'04	YTZ12S-BS-N	NTZ12S-BS
150	PS I (PES)	'06→'11	YTX7L-BS-N	NTX7L-BS	250	NS F	'84	YT4L-BS-N	NT4L-BS
150	SH	'00→'06	YTX7L-BS-N	NTX7L-BS	250	NS R	'84	YT4L-BS-N	NT4L-BS
150	SH i	'05→'12	YTX7L-BS-N	NTX7L-BS	250	NS R	'86	YT4L-BS-N	NT4L-BS
150	SH I	'14→'20	YTZ7S-BS-N	NTZ7S-BS	250	NSR R	'86	YT4L-BS-N	NT4L-BS
150	SH i (Tamb. Post.)	'09→'12	YTX7L-BS-N	NTX7L-BS	250	NSR R	'88→'92	YT4L-BS-N	NT4L-BS
150	SH i ABS	'13→'16	YTZ7S-BS-N	NTZ7S-BS	250	NSR R	'94	YT4L-BS-N	NT4L-BS
150	SH i Special	'05→'12	YTX7L-BS-N	NTX7L-BS	250	NSR R2	'94	YT4L-BS-N	NT4L-BS
150	SH i Sport	'05→'08	YTX7L-BS-N	NTX7L-BS	250	NSS Reflex	'00→'07	YTZ12S-BS-N	NTZ12S-BS
150	S-Wing (FES)	'07→'13	YTX7L-BS-N	NTX7L-BS	250	NX	'87→'93	YTX7L-BS-N	NTX7L-BS
150	S-Wing ABS (FES A)	'07→'13	YTX7L-BS-N	NTX7L-BS	250	NX 2	'90→'93	YTX7L-BS-N	NTX7L-BS
200	CB B	'76→'79	YB9-B WA-N	NB9-B WA	250	NX AX-1	'89→'94	YTX7L-BS-N	NTX7L-BS
200	CM T	'80→'84	YB9-B WA-N	NB9-B WA	250	PS Big Ruckus	'05→'06	YTZ12S-BS-N	NTZ12S-BS
200	TRX	'90→'93	YTX12-BS-N	NTX12-BS	250	TRX	'85→'87	YTX12-BS-N	NTX12-BS
200	TRX D	'91→'97	YTX12-BS-N	NTX12-BS	250	TRX	'97→'99	YTX12-BS-N	NTX12-BS
200	TRX SX	'86→'87	YTX12-BS-N	NTX12-BS	250	TRX EX	'01→'08	YTX9-BS-N	NTX9-BS
223	FTR	'00→'02	YTX5L-BS-N	NTX5L-BS	250	TRX R	'86→'89	YTX12-BS-N	NTX12-BS
223	FTR A	'02	YTX5L-BS-N	NTX5L-BS	250	TRX Re CON	'00→'14	YTX12-BS-N	NTX12-BS
230	CRF F	'04→'19	YTX5L-BS-N	NTX5L-BS	250	TRX X	'09→'14	YTX9-BS-N	NTX9-BS
230	CRF L	'08→'10	YTZ7S-BS-N	NTZ7S-BS	250	VT C Magna	'94→'97	YTX7L-BS-N	NTX7L-BS
230	CRF M	'09→'10	YTZ7S-BS-N	NTZ7S-BS	250	VT F	'83→'86	YB9-B WA-N	NB9-B WA
230	SL Free Lands.	'97→'01	YTX5L-BS-N	NTX5L-BS	250	VT FL Spada	'88→'90	YTX7L-BS-N	NTX7L-BS
250	ATC ES	'85→'88	YTX12-BS-N	NTX12-BS	250	VTR	'98→'02	YTX7L-BS-N	NTX7L-BS
250	ATC R	'81→'86	YTX12-BS-N	NTX12-BS	250	VTR	'03→'07	YTZ7S-BS-N	NTZ7S-BS
250	CB F Hornet	'96→'01	YTX7L-BS-N	NTX7L-BS	250	VTR	'09→'10	YTZ7S-BS-N	NTZ7S-BS
250	CB Nighthawk	'92→'00	YTX7L-BS-N	NTX7L-BS	300	CB F ABS	'15→'19	YTX7L-BS-N	NTX7L-BS
250	CB RS	'80→'83	YB9-B WA-N	NB9-B WA	300	CBR R ABS	'14→'19	YTX7L-BS-N	NTX7L-BS
250	CB Two Fifty	'92→'05	YTX7L-BS-N	NTX7L-BS	300	Forza (NSS)	'13→'15	YTZ12S-BS-N	NTZ12S-BS
250	CBF	'04→'06	YTX7L-BS-N	NTX7L-BS	300	Forza ABS (NSS A)	'13→'20	YTZ12S-BS-N	NTZ12S-BS
250	CBR R	'87→'89	YTX7L-BS-N	NTX7L-BS	300	SH i	'06→'14	YTZ12S-BS-N	NTZ12S-BS
250	CBR R	'11→'13	YTX7L-BS-N	NTX7L-BS	300	SH i ABS	'06→'20	YTZ12S-BS-N	NTZ12S-BS
250	CBR R ABS	'11→'13	YTX7L-BS-N	NTX7L-BS	300	SH i Special	'13→'14	YTZ12S-BS-N	NTZ12S-BS
250	CBR RR	'90→'94	YTX7L-BS-N	NTX7L-BS	300	SH i Sport	'06→'10	YTZ12S-BS-N	NTZ12S-BS
250	CBX	'84→'98	YTX7L-BS-N	NTX7L-BS	300	SH i Sport ABS	'18→'19	YTZ12S-BS-N	NTZ12S-BS
250	CBX RS	'84→'84	YTX7L-BS-N	NTX7L-BS	300	SH i Sporty	'13→'14	YTZ12S-BS-N	NTZ12S-BS
250	CD U	'88→'92	YTX9-BS-N	NTX9-BS	300	TRX	'88→'00	YTX14-BS-N	NTX14-BS
250	CH Elite	'87→'90	YTX12-BS-N	NTX12-BS	300	TRX EX	'93→'08	YTX9-BS-N	NTX9-BS
250	CH Spacy	'85→'86	YTX12-BS-N	NTX12-BS	300	TRX FW	'88→'00	YTX14-BS-N	NTX14-BS
250	CJ T	'77	YB9-B WA-N	NB9-B WA	300	TRX X	'09	YTX9-BS-N	NTX9-BS
250	CM	'83→'84	YB9-B WA-N	NB9-B WA	350	FL R Odyssey	'85→'87	YTX12-BS-N	NTX12-BS
250	CM C	'82→'85	YB9-B WA-N	NB9-B WA	350	TRX	'86→'93	YTX14-BS-N	NTX14-BS
250	CM T	'81	YB9-B WA-N	NB9-B WA	350	TRX ES Rancher	'00→'03	YTX14-BS-N	NTX14-BS
250	CMX	'88	YTX7L-BS-N	NTX7L-BS	360	CJ T	'76→'78	YB9-B WA-N	NB9-B WA
					400	CB SF Super Four	'92→'96	YTX9-BS-N	NTX9-BS

BATTERIE / BATTERY

CC	Modello Model	Anno Years	Vecchio Codice Old Code	Nuovo Codice New Code	CC	Modello Model	Anno Years	Vecchio Codice Old Code	Nuovo Codice New Code
400	CB SF Super Four	'99→'01	YTX7A-BS-N	NTX7A-BS	500	TRX FA Fourtrax	'01→'11	YTX14-BS-N	NTX14-BS
400	CB SF Super Four	'01→'05	YTZ10S-BS-N	NTZ10S-BS		Foreman Auto			
400	CB SF2 Sup. Four	'97	YTX9-BS-N	NTX9-BS	500	TRX FE Fourtrax	'05→'12	YTX14-BS-N	NTX14-BS
400	CB SF3 Sup. Four	'97	YTX9-BS-N	NTX9-BS		Foreman			
400	CB T	'78	YB9-B WA-N	NB9-B WA	500	TRX FM Fourtrax	'05→'10	YTX14-BS-N	NTX14-BS
400	CB-1	'89→'90	YTX9-BS-N	NTX9-BS		Foreman			
400	CBR R	'86→'87	YTX9-BS-N	NTX9-BS	500	TRX FM Fourtrax	'11→'12	YTX14-BS-N	NTX14-BS
400	CBR RR	'88→'94	YTX9-BS-N	NTX9-BS		Foreman			
400	FL R Odys. Pilot	'89→'93	YTX14-BS-N	NTX14-BS	500	TRX FPE Fourtrax	'08→'12	YTX14-BS-N	NTX14-BS
400	NS R	'85→'89	YTX5L-BS-N	NTX5L-BS		Foreman			
400	NT BROS	'88	YTX9-BS-N	NTX9-BS	500	TRX TM Fourtrax	'05→'06	YTX14-BS-N	NTX14-BS
400	NV C STEED	'88→'89	YTX9-BS-N	NTX9-BS		Foreman			
400	NV C STEED	'95→'97	YTX9-BS-N	NTX9-BS	600	CB F Hornet	'98→'06	YTX7L-BS-N	NTX7L-BS
400	NV DC	'00→'02	YTZ10S-BS-N	NTZ10S-BS	600	CB F Hornet	'07→'13	YTZ10S-BS-N	NTZ10S-BS
	Shadow Slasher				600	CB F Hornet ABS	'00→'04	YTX7L-BS-N	NTX7L-BS
400	RVF R	'94→'96	YTX7A-BS-N	NTX7A-BS	600	CB F Hornet ABS	'07→'13	YTZ10S-BS-N	NTZ10S-BS
400	Silver Wing (FJS D)	'06→'08	YTZ12S-BS-N	NTZ12S-BS	600	CB F Hornet S	'99→'04	YTX7L-BS-N	NTX7L-BS
400	Silver Wing ABS	'06→'08	YTZ12S-BS-N	NTZ12S-BS	600	CBF N	'04→'07	YTX7L-BS-N	NTX7L-BS
	(FJS A)				600	CBF N	'08→'12	YTZ10S-BS-N	NTZ10S-BS
400	SW-T (FJS D)	'09→'16	YTZ12S-BS-N	NTZ12S-BS	600	CBF N ABS	'04→'07	YTX7L-BS-N	NTX7L-BS
400	SW-T ABS (FJS A)	'09→'16	YTZ12S-BS-N	NTZ12S-BS	600	CBF N ABS	'08→'12	YTZ10S-BS-N	NTZ10S-BS
400	TRX EX	'99→'08	YTX9-BS-N	NTX9-BS	600	CBF S	'04→'07	YTX7L-BS-N	NTX7L-BS
400	TRX FA Fourtrax	'04→'07	YTX14-BS-N	NTX14-BS	600	CBF S	'08→'13	YTZ10S-BS-N	NTZ10S-BS
400	TRX FGA Fourtrax	'04→'07	YTX14-BS-N	NTX14-BS	600	CBF S ABS	'04→'07	YTX7L-BS-N	NTX7L-BS
	Ranch. AT GScape				600	CBF S ABS	'08→'13	YTZ10S-BS-N	NTZ10S-BS
400	TRX FW	'95→'02	YTX14-BS-N	NTX14-BS	600	CBR F	'87→'00	YTX9-BS-N	NTX9-BS
400	TRX X	'09→'15	YTX9-BS-N	NTX9-BS	600	CBR F	'01→'07	YTZ10S-BS-N	NTZ10S-BS
400	VFR R	'89→'92	YTX7A-BS-N	NTX7A-BS	600	CBR F	'11→'13	YTZ10S-BS-N	NTZ10S-BS
400	VRX	'96→'96	YTX9-BS-N	NTX9-BS	600	CBR F ABS	'11→'13	YTZ10S-BS-N	NTZ10S-BS
420	TRX FA F-trax Auto	'09→'11	YTX14-BS-N	NTX14-BS	600	CBR F Sport	'01→'02	YTZ10S-BS-N	NTZ10S-BS
420	TRX FEF-trax	'07→'11	YTX14-BS-N	NTX14-BS	600	CBR F4	'99→'00	YTX9-BS-N	NTX9-BS
420	TRX FM F-trax Auto	'07→'11	YTX14-BS-N	NTX14-BS	600	CBR RR	'03→'16	YTZ10S-BS-N	NTZ10S-BS
420	TRX FPM F-trax	'09→'11	YTX14-BS-N	NTX14-BS	600	CBR RR ABS	'09→'16	YTZ10S-BS-N	NTZ10S-BS
420	TRX TE F-trax ES	'07→'09	YTX14-BS-N	NTX14-BS	600	NTV Revere	'88→'92	YTX9-BS-N	NTX9-BS
420	TRX TE Fourtrax	'07→'08	YTX14-BS-N	NTX14-BS	600	NTV Revere	'88→'92	YTX9-BS-N	NTX9-BS
	Rancher ES				600	Silver Wing (FJS D)	'01→'05	YTZ12S-BS-N	NTZ12S-BS
420	TRX TM	'07→'11	YTX14-BS-N	NTX14-BS	600	Silver Wing ABS	'05→'09	YTZ12S-BS-N	NTZ12S-BS
450	CRF R	'17→'17	YT4L-BS-N	NT4L-BS		(FJS A)			
450	CRF RX	'17→'19	YT4L-BS-N	NT4L-BS	600	SW-T (FJS D)	'11→'16	YTZ12S-BS-N	NTZ12S-BS
450	CRF X	'05→'16	YTZ7S-BS-N	NTZ7S-BS	600	SW-T ABS (FJS A)	'12→'17	YTZ12S-BS-N	NTZ12S-BS
450	TRX ES	'98→'01	YTX14-BS-N	NTX14-BS	600	VT C Shadow Cust	'86→'00	YTX9-BS-N	NTX9-BS
450	TRX R	'04→'14	YTZ7S-BS-N	NTZ7S-BS	650	CB F	'14→'16	YTZ10S-BS-N	NTZ10S-BS
500	CB	'94→'03	YTX9-BS-N	NTX9-BS	650	CB F ABS	'14→'19	YTZ10S-BS-N	NTZ10S-BS
500	CB F	'13→'16	YTZ10S-BS-N	NTZ10S-BS	650	CBR Neo	'19→'20	YTZ10S-BS-N	NTZ10S-BS
500	CB F ABS	'13→'20	YTZ10S-BS-N	NTZ10S-BS		Sports Cafe			
500	CB S	'98→'03	YTX9-BS-N	NTX9-BS	650	CBR F	'14→'16	YTZ10S-BS-N	NTZ10S-BS
500	CB X	'13→'15	YTZ10S-BS-N	NTZ10S-BS	650	CBR F ABS	'14→'20	YTZ10S-BS-N	NTZ10S-BS
500	CB X ABS	'13→'20	YTZ10S-BS-N	NTZ10S-BS	650	CBR R	'19→'20	YTZ10S-BS-N	NTZ10S-BS
500	CBF	'04→'07	YTZ10S-BS-N	NTZ10S-BS	650	CX E	'83	YB14L-A2 WA-N	NB14L-A2 WA
500	CBF ABS	'04→'07	YTZ10S-BS-N	NTZ10S-BS	650	CX T Turbo	'83	YB14L-A2 WA-N	NB14L-A2 WA
500	CBR F	'87→'90	YTX9-BS-N	NTX9-BS	650	FMX	'05→'08	YTX9-BS-N	NTX9-BS
500	CBR R	'13→'15	YTZ10S-BS-N	NTZ10S-BS	650	FX Vigor	'99→'03	YTX9-BS-N	NTX9-BS
500	CBR R ABS	'13→'20	YTZ10S-BS-N	NTZ10S-BS	650	GL D2	'84	YB14L-A2 WA-N	NB14L-A2 WA
500	CX	'79→'81	YB14L-A2 WA-N	NB14L-A2 WA	650	NT Bros	'88→'92	YTX9-BS-N	NTX9-BS
500	CX C	'80→'82	YB14L-A2 WA-N	NB14L-A2 WA	650	NT GT Hawk	'88→'91	YTX9-BS-N	NTX9-BS
500	CX TC Turbo	'82	YB14L-A2 WA-N	NB14L-A2 WA	650	NT V Deauville	'02→'03	YTZ10S-BS-N	NTZ10S-BS
500	FT	'82→'84	YB14L-A2 WA-N	NB14L-A2 WA	650	NT V Deauville	'04→'05	YTZ14S-BS-N	NTZ14S-BS
500	GL D Silver Wing	'82	YB14L-A2 WA-N	NB14L-A2 WA	650	NTV Revere	'88→'97	YTX9-BS-N	NTX9-BS
500	NX Dominator	'88→'99	YTX9-BS-N	NTX9-BS	650	NX Dominator	'88→'02	YTX9-BS-N	NTX9-BS
500	TRX FA Fourtrax	'12→'13	YTX14-BS-N	NTX14-BS	650	XL V Transalp	'00→'07	YTZ12S-BS-N	NTZ12S-BS
	Foreman				650	XR L	'93→'19	YTX9-BS-N	NTX9-BS

BATTERIE / BATTERY

CC	Modello Model	Anno Years	Vecchio Codice Old Code	Nuovo Codice New Code	CC	Modello Model	Anno Years	Vecchio Codice Old Code	Nuovo Codice New Code
680	DN-01 ABS	'08→'11	YTZ14S-BS-N	NTZ14S-BS	750	VT C2B	'11→'12	YTZ14S-BS-N	NTZ14S-BS
700	CTX ABS DCT	'14→'16	YTZ12S-BS-N	NTZ12S-BS		Shadow Phantom			
700	CTX N ABS DCT	'14→'16	YTZ12S-BS-N	NTZ12S-BS	750	VT C2B	'13→'16	YTZ14S-BS-N	NTZ14S-BS
700	MUV Big Red	'09	YTX14-BS-N	NTX14-BS		Shadow Spirit			
700	NC Integra DCT ABS	'12→'14	YTZ12S-BS-N	NTZ12S-BS	750	VT C2S	'10→'14	YTZ14S-BS-N	NTZ14S-BS
700	NC S	'12→'14	YTZ12S-BS-N	NTZ12S-BS		Shadow Spirit			
700	NC S ABS	'12→'14	YTZ12S-BS-N	NTZ12S-BS	750	VT CS Shadow	'10→'14	YTZ14S-BS-N	NTZ14S-BS
700	NC S DCT ABS	'12→'14	YTZ12S-BS-N	NTZ12S-BS	750	VT DC Black W.	'00→'04	YTZ14S-BS-N	NTZ14S-BS
700	NC X	'12→'14	YTZ12S-BS-N	NTZ12S-BS	750	VT DC Sh. Spirit	'07→'09	YTZ14S-BS-N	NTZ14S-BS
700	NC X ABS	'12→'14	YTZ12S-BS-N	NTZ12S-BS	750	VT S	'11→'11	YTZ14S-BS-N	NTZ14S-BS
700	NC X DCT ABS	'12→'14	YTZ12S-BS-N	NTZ12S-BS	750	VT S VTRS	'10→'10	YTZ14S-BS-N	NTZ14S-BS
700	NTV Deauville	'06→'13	YTZ14S-BS-N	NTZ14S-BS	750	VT C Sh. Aero	'18→'19	YTZ14S-BS-N	NTZ14S-BS
700	NTV Deauv. ABS	'07→'15	YTZ14S-BS-N	NTZ14S-BS	750	VT C S	'18→'20	YTZ14S-BS-N	NTZ14S-BS
700	TRX XX	'08→'09	YTX9-BS-N	NTX9-BS		Shadow Aero ABS			
700	VF S	'84→'85	YB14L-A2 WA-N	NB14L-A2 WA	750	X-ADV	'17→'20	YTZ14S-BS-N	NTZ14S-BS
700	XL V Transalp	'08→'13	YTZ14S-BS-N	NTZ14S-BS	750	XRV Africa Twin	'93→'03	YTX14-BS-N	NTX14-BS
700	XL V Tran. ABS	'08→'13	YTZ14S-BS-N	NTZ14S-BS	800	PC Pacific Coast	'89→'98	YTX12-BS-N	NTX12-BS
750	CB C Custom	'80→'81	YB14L-A2 WA-N	NB14L-A2 WA	800	VFR	'02→'05	YTZ12S-BS-N	NTZ12S-BS
750	CB F	'76	YB14L-A2 WA-N	NB14L-A2 WA	800	VFR ABS	'02→'05	YTZ12S-BS-N	NTZ12S-BS
750	CB F	'79→'84	YB14L-A2 WA-N	NB14L-A2 WA	800	VFR F ABS	'14→'20	YTZ12S-BS-N	NTZ12S-BS
750	CB F1	'77	YB14L-A2 WA-N	NB14L-A2 WA	800	VFR FI	'98→'01	YTX12-BS-N	NTX12-BS
750	CB F2	'78	YB14L-A2 WA-N	NB14L-A2 WA	800	VFR FI	'02→'05	YTZ12S-BS-N	NTZ12S-BS
750	CB K	'69→'82	YB14L-A2 WA-N	NB14L-A2 WA	800	VFR VTEC	'06→'09	YTZ12S-BS-N	NTZ12S-BS
750	Nc Integra DTC	'14→'20	YTZ14S-BS-N	NTZ14S-BS	800	VFR VTEC ABS	'06→'13	YTZ12S-BS-N	NTZ12S-BS
750	NC Integra DTCS	'14→'20	YTZ14S-BS-N	NTZ14S-BS	800	VFR X Crossr.	'15	YTZ12S-BS-N	NTZ12S-BS
750	NC J NM 4 Vultus	'15→'19	YTZ14S-BS-N	NTZ14S-BS	800	VFR X	'11→'20	YTZ12S-BS-N	NTZ12S-BS
750	NC S	'14	YTZ14S-BS-N	NTZ14S-BS		Crossrunner ABS			
750	NC S ABS	'14→'20	YTZ14S-BS-N	NTZ14S-BS	900	CB F	'82→'83	YB14L-A2 WA-N	NB14L-A2 WA
750	NC S ABS (35Kw)	'18→'20	YTZ14S-BS-N	NTZ14S-BS	900	CB F Bol D'or	'79→'81	YB14L-A2 WA-N	NB14L-A2 WA
750	NC S ABS DCT	'16→'20	YTZ14S-BS-N	NTZ14S-BS	900	CB F Hornet	'02→'07	YTZ10S-BS-N	NTZ10S-BS
750	NC S ABS DCT (35Kw)	'18→'20	YTZ14S-BS-N	NTZ14S-BS	900	CBR Ev. Blade	'99	YTX9-BS-N	NTX9-BS
750	NC S DCT	'14→'15	YTZ14S-BS-N	NTZ14S-BS	900	CBR RR Fireblade	'92→'99	YTX9-BS-N	NTX9-BS
750	NC X	'14	YTZ14S-BS-N	NTZ14S-BS	929	CBR RR Fireblade	'00→'01	YTZ10S-BS-N	NTZ10S-BS
750	NC X ABS	'14→'20	YTZ14S-BS-N	NTZ14S-BS	954	CBR RR Fireblade	'02→'03	YTZ10S-BS-N	NTZ10S-BS
750	NC X ABS (35Kw)	'18→'20	YTZ14S-BS-N	NTZ14S-BS	1000	CB F Big One	'93→'97	YTX12-BS-N	NTX12-BS
750	NC X ABS DCT	'14→'20	YTZ14S-BS-N	NTZ14S-BS	1000	CB R	'09→'15	YTZ10S-BS-N	NTZ10S-BS
750	NC X ABS DCT (35Kw)	'18→'20	YTZ14S-BS-N	NTZ14S-BS	1000	CB R ABS	'09→'20	YTZ10S-BS-N	NTZ10S-BS
750	RVF RC45	'94→'98	YTX9-BS-N	NTX9-BS	1000	CB R+ ABS	'18→'20	YTZ10S-BS-N	NTZ10S-BS
750	VF C	'93→'04	YTX12-BS-N	NTX12-BS	1000	CBF	'06→'12	YTZ10S-BS-N	NTZ10S-BS
750	VF C2	'97→'00	YTX12-BS-N	NTX12-BS	1000	CBF ABS	'06→'10	YTZ10S-BS-N	NTZ10S-BS
750	VF CD	'95→'96	YTX12-BS-N	NTX12-BS	1000	CBF F	'10→'15	YTZ10S-BS-N	NTZ10S-BS
750	VF S Sabre	'82	YB14L-A2 WA-N	NB14L-A2 WA	1000	CBF F ABS	'10→'16	YTZ10S-BS-N	NTZ10S-BS
750	VFR F	'86→'97	YTX12-BS-N	NTX12-BS	1000	CBF FS ABS	'10→'13	YTZ10S-BS-N	NTZ10S-BS
750	VFR R RC30	'88→'93	YTX9-BS-N	NTX9-BS	1000	CBF FT ABS	'10→'13	YTZ10S-BS-N	NTZ10S-BS
750	VT C	'10→'15	YTZ14S-BS-N	NTZ14S-BS	1000	CBF S ABS	'07→'11	YTZ10S-BS-N	NTZ10S-BS
750	VT C Shadow	'97→'03	YTX14-BS-N	NTX14-BS	1000	CBF ST ABS	'07→'15	YTZ10S-BS-N	NTZ10S-BS
750	VT C Shadow	'04→'07	YTZ12S-BS-N	NTZ12S-BS	1000	CBR RR	'04→'07	YTZ10S-BS-N	NTZ10S-BS
750	VT C Shadow	'08	YTZ14S-BS-N	NTZ14S-BS	1000	CBR RR	'08→'19	YTZ7S-BS-N	NTZ7S-BS
750	VT C Shadow ABS	'04→'08	YTZ12S-BS-N	NTZ12S-BS	1000	CBR RR ABS	'09→'16	YTZ10S-BS-N	NTZ10S-BS
750	VT C Shadow ABS	'12→'14	YTZ14S-BS-N	NTZ14S-BS	1000	CBR RR SP	'17→'19	YTZ7S-BS-N	NTZ7S-BS
750	VT C Shadow AERO	'09	YTZ14S-BS-N	NTZ14S-BS	1000	CBR RR SP ABS	'14→'16	YTZ7S-BS-N	NTZ7S-BS
750	VT C Shadow AERO ABS	'09	YTZ12S-BS-N	NTZ12S-BS	1000	CBR RR SP2	'17→'19	YTZ7S-BS-N	NTZ7S-BS
750	VT C2 Shadow	'97→'01	YTX14-BS-N	NTX14-BS	1000	CBR RR-R SP	'20	YTZ7S-BS-N	NTZ7S-BS
750	VT C2 Shadow	'09→'14	YTZ14S-BS-N	NTZ14S-BS	1000	CRF	'16→'17	YTZ14S-BS-N	NTZ14S-BS
750	VT C2 Shad. Spirit	'07→'08	YTZ14S-BS-N	NTZ14S-BS		Africa Twin ABS			
750	VT C2B Shadow	'09→'10	YTZ14S-BS-N	NTZ14S-BS	1000	CRF Africa Twin DCT ABS	'16→'17	YTZ14S-BS-N	NTZ14S-BS
					1000	CRF Africa Twin Replica ABS	'17	YTZ14S-BS-N	NTZ14S-BS
					1000	CRF L	'16→'17	YTZ14S-BS-N	NTZ14S-BS
						Africa Twin ABS			

BATTERIE / BATTERY

CC	Modello Model	Anno Years	Vecchio Codice Old Code	Nuovo Codice New Code
1000	CRF L Africa Twin DCT ABS	'16→'17	YTZ14S-BS-N	NTZ14S-BS
1000	VTR F Firestorm	'97→'00	YTX12-BS-N	NTX12-BS
1000	VTR F Firestorm	'01→'06	YTZ12S-BS-N	NTZ12S-BS
1000	VTR SP1	'00→'01	YTZ12S-BS-N	NTZ12S-BS
1000	VTR SP2	'02→'06	YTZ12S-BS-N	NTZ12S-BS
1000	XL V Varadero	'99→'02	YTX14-BS-N	NTX14-BS
1100	CB ABS	'13→'15	YTZ14S-BS-N	NTZ14S-BS
1100	CB EX	'14→'16	YTZ14S-BS-N	NTZ14S-BS
1100	CB EX ABS	'17→'20	YTZ14S-BS-N	NTZ14S-BS
1100	CB F	'83	YB14L-A2 WA-N	NB14L-A2 WA
1100	CB R	'80→'85	YB14L-A2 WA-N	NB14L-A2 WA
1100	CB RS ABS	'17→'20	YTZ14S-BS-N	NTZ14S-BS
1100	CB S ABS	'14	YTZ14S-BS-N	NTZ14S-BS
1100	CB SF X11	'00→'03	YTX12-BS-N	NTX12-BS
1100	CBR XX Blackbird	'97→'00	YTX12-BS-N	NTX12-BS
1100	CBR XX Blackbird	'01→'08	YTZ12S-BS-N	NTZ12S-BS
1100	ST PAN European	'90→'02	YTX14-BS-N	NTX14-BS
1100	ST Pan E. ABS	'92→'02	YTX14-BS-N	NTX14-BS
1100	VFR C2	'00→'05	YTX14-BS-N	NTX14-BS
1200	VFR F ABS	'10→'16	YTZ14S-BS-N	NTZ14S-BS
1200	VFR F DCT ABS	'10→'17	YTZ14S-BS-N	NTZ14S-BS
1200	VFR X Crosstourer ABS	'12→'20	YTZ14S-BS-N	NTZ14S-BS
1200	VFR X Crosst. DCT ABS	'13→'20	YTZ14S-BS-N	NTZ14S-BS
1300	CB DC X4	'97→'00	YTX14-BS-N	NTX14-BS
1300	CB F	'98→'01	YTZ14S-BS-N	NTZ14S-BS
1300	CB F Superfour	'03→'09	YTZ14S-BS-N	NTZ14S-BS
1300	CB N	'05→'12	YTZ14S-BS-N	NTZ14S-BS
1300	CB N ABS	'05→'12	YTZ14S-BS-N	NTZ14S-BS
1300	CB S	'05→'09	YTZ14S-BS-N	NTZ14S-BS
1300	CB S ABS	'05→'13	YTZ14S-BS-N	NTZ14S-BS
1300	CTX	'14	YTZ14S-BS-N	NTZ14S-BS
1300	CTX ABS	'14→'16	YTZ14S-BS-N	NTZ14S-BS
1300	ST Pan European	'02→'09	YTZ14S-BS-N	NTZ14S-BS
1300	ST Pan E. ABS	'02→'16	YTZ14S-BS-N	NTZ14S-BS
1300	VT CT ABS	'11→'13	YTZ14S-BS-N	NTZ14S-BS
1300	VT CX	'10→'17	YTZ14S-BS-N	NTZ14S-BS
1300	VT CX ABS	'10→'20	YTZ14S-BS-N	NTZ14S-BS
1300	VTX S	'03→'08	YTX14-BS-N	NTX14-BS
1500	GL C F6C	'97→'03	YTX14-BS-N	NTX14-BS

HRD

50	Sonic 2 Enduro	'99→'01	YTX7A-BS-N	NTX7A-BS
50	Sonic 2 SuperM.	'99→'01	YTX7A-BS-N	NTX7A-BS

HUSABERG

250	FE E 4T	'13→'14	YTX5L-BS-N	NTX5L-BS
250	TE 2T	'14	YTX5L-BS-N	NTX5L-BS
300	TE 2T Enduro	'11→'13	YT4L-BS-N	NT4L-BS
300	TE 2T Enduro	'14	YTX5L-BS-N	NTX5L-BS
350	FE E 4T	'14	YTX5L-BS-N	NTX5L-BS
350	TE	'96→'99	YTX9-BS-N	NTX9-BS
400	FE	'00→'02	YTX5L-BS-N	NTX5L-BS
450	FE	'08→'12	YTZ7S-BS-N	NTZ7S-BS
450	FE	'13→'14	YTX5L-BS-N	NTX5L-BS
450	FE E	'03→'08	YTZ7S-BS-N	NTZ7S-BS
501	FE	'00→'02	YTX5L-BS-N	NTX5L-BS
501	FE 4T	'13→'14	YTX5L-BS-N	NTX5L-BS

CC	Modello Model	Anno Years	Vecchio Codice Old Code	Nuovo Codice New Code
501	FE E	'03→'04	YTX5L-BS-N	NTX5L-BS
501	TE	'96→'99	YTX9-BS-N	NTX9-BS
550	FE E	'04→'08	YTZ7S-BS-N	NTZ7S-BS
550	FS E	'05→'07	YTZ7S-BS-N	NTZ7S-BS
600	FE Enduro	'00→'03	YTX5L-BS-N	NTX5L-BS
650	FE E	'04→'05	YTZ7S-BS-N	NTZ7S-BS
650	FS E Supermoto	'05→'08	YTZ7S-BS-N	NTZ7S-BS
650	FS Supermotard	'04→'07	YTZ7S-BS-N	NTZ7S-BS

HUSQVARNA

125	SMR	'11→'13	YT4L-BS-N	NT4L-BS
125	SMS	'12→'13	YT4L-BS-N	NT4L-BS
125	SMS 4	'11→'14	YT4L-BS-N	NT4L-BS
125	WRE	'94→'13	YT4L-BS-N	NT4L-BS
250	FC	'14→'15	YT4L-BS-N	NT4L-BS
250	FE	'14→'16	YTX5L-BS-N	NTX5L-BS
250	TE 2T	'14→'16	YTX5L-BS-N	NTX5L-BS
300	TE 2T	'14→'16	YTX5L-BS-N	NTX5L-BS
350	FC	'14→'15	YT4L-BS-N	NT4L-BS
350	FE	'14→'16	YTX5L-BS-N	NTX5L-BS
400	TE	'01→'02	YTX14-BS-N	NTX14-BS
401	Svartpilen	'17→'20	YT12A-BS-N	NT12A-BS
401	Vitpilen	'17→'20	YT12A-BS-N	NT12A-BS
410	TE	'97→'99	YT4L-BS-N	NT4L-BS
410	TE	'00→'01	YTX14-BS-N	NTX14-BS
410	TE E	'00→'00	YTX14-BS-N	NTX14-BS
450	FC	'14→'15	YT4L-BS-N	NT4L-BS
450	FE	'14→'16	YTX5L-BS-N	NTX5L-BS
450	FS	'15	YT4L-BS-N	NT4L-BS
450	SM R	'03→'10	YT4L-BS-N	NT4L-BS
450	SM RR	'08→'10	YT4L-BS-N	NT4L-BS
450	SMR RR	'06→'07	YT4L-BS-N	NT4L-BS
450	TC	'02	YT4L-BS-N	NT4L-BS
450	TE	'02→'05	YT4L-BS-N	NT4L-BS
450	TE	'06→'10	YTZ7S-BS-N	NTZ7S-BS
501	FE	'14→'19	YTX5L-BS-N	NTX5L-BS
510	TE	'04→'10	YTZ7S-BS-N	NTZ7S-BS
610	SM IE	'07→'09	YTX14-BS-N	NTX14-BS
610	SM S	'02→'06	YTX7L-BS-N	NTX7L-BS
701	701 Enduro	'16→'20	YTZ10S-BS-N	NTZ10S-BS
701	701 Enduro LR	'20	YTZ10S-BS-N	NTZ10S-BS
701	701 Supermoto	'16→'20	YTZ10S-BS-N	NTZ10S-BS
701	701 Svartpilen	'19→'20	YTZ10S-BS-N	NTZ10S-BS
701	701 Vitpilen	'18→'20	YTZ10S-BS-N	NTZ10S-BS
900	Nuda	'12→'13	YTX14-BS-N	NTX14-BS
900	Nuda R	'12→'13	YTX14-BS-N	NTX14-BS

HYOSUNG

50	SD	'00→'06	YTX5L-BS-N	NTX5L-BS
50	SF Prima	'00→'06	YTX5L-BS-N	NTX5L-BS
50	SF R Rally	'00→'06	YTX5L-BS-N	NTX5L-BS
100	TE	'05→'07	YTX5L-BS-N	NTX5L-BS
125	GT Comet	'03→'10	YTX14-BS-N	NTX14-BS
125	GT Naked	'03→'12	YTX14-BS-N	NTX14-BS
125	GT PI Naked	'13→'15	YTX14-BS-N	NTX14-BS
125	GT R	'06→'15	YTX14-BS-N	NTX14-BS
125	GV Aguila	'01→'10	YTX9-BS-N	NTX9-BS
125	GV C	'07→'15	YTX9-BS-N	NTX9-BS
125	MS3	'07→'09	YTX9-BS-N	NTX9-BS
125	RT Karion	'02→'15	YTX7A-BS-N	NTX7A-BS
125	RX	'01→'07	YTX7A-BS-N	NTX7A-BS
125	RX D	'08→'11	YTX7A-BS-N	NTX7A-BS

BATTERIE / BATTERY

CC	Modello Model	Anno Years	Vecchio Codice Old Code	Nuovo Codice New Code	CC	Modello Model	Anno Years	Vecchio Codice Old Code	Nuovo Codice New Code
125	RX D Karion	'07→'11	YTX7A-BS-N	NTX7A-BS	250	KL Super Sherpa	'09→'10	YTX7L-BS-N	NTX7L-BS
125	XRX SM SuperM.	'07→'08	YTX7A-BS-N	NTX7A-BS	250	KLE	'95	YTX7L-BS-N	NTX7L-BS
250	GT Comet	'04→'10	YTX14-BS-N	NTX14-BS	250	KLE	'97	YTX7L-BS-N	NTX7L-BS
250	GT Naked	'11→'12	YTX14-BS-N	NTX14-BS	250	KLE	'00→'01	YTX7L-BS-N	NTX7L-BS
250	GT PI Naked	'13→'15	YTX14-BS-N	NTX14-BS	250	KLR	'85→'05	YB4L-B WA-N	NB4L-B WA
250	GT R	'07→'15	YTX14-BS-N	NTX14-BS	250	KLX	'94	YTX7L-BS-N	NTX7L-BS
250	GV Aquila	'04→'07	YTX9-BS-N	NTX9-BS	250	KLX	'09→'19	YTX7L-BS-N	NTX7L-BS
250	GV C	'08→'15	YTX9-BS-N	NTX9-BS	250	KLX D-Tracker	'98→'03	YTX7L-BS-N	NTX7L-BS
250	MS3 I	'07→'09	YTX9-BS-N	NTX9-BS	250	KLX S	'06→'07	YTX7L-BS-N	NTX7L-BS
450	TE Quad Rapiere	'06→'11	YTX9-BS-N	NTX9-BS	250	KLX S	'09→'14	YTX7L-BS-N	NTX7L-BS
650	GT Comet Naked	'04→'08	YTX14-BS-N	NTX14-BS	250	KR-1	'89	YB4L-B WA-N	NB4L-B WA
650	GT Naked	'09→'11	YTX14-BS-N	NTX14-BS	250	KR-1S	'90→'92	YB4L-B WA-N	NB4L-B WA
650	GT PI Naked	'13→'15	YTX14-BS-N	NTX14-BS	250	NINJA R	'08→'12	YTX9-BS-N	NTX9-BS
650	GT R	'06→'15	YTX14-BS-N	NTX14-BS	250	Z SL BR	'15→'17	YTX9-BS-N	NTX9-BS
650	GT S	'05→'08	YTX14-BS-N	NTX14-BS	250	Z SL BR ABS	'15→'17	YTX9-BS-N	NTX9-BS
650	GT X	'07→'07	YTX14-BS-N	NTX14-BS	250	Z SL BX Ninja	'15	YTX9-BS-N	NTX9-BS
650	GV Aquila	'04→'06	YTX14-BS-N	NTX14-BS	250	Z SL BX Ninja ABS	'15	YTX9-BS-N	NTX9-BS
650	GV I	'07→'15	YTX14-BS-N	NTX14-BS	250	ZR Balius	'91→'95	YTX7L-BS-N	NTX7L-BS
700	ST 7	'10→'15	YTX14-BS-N	NTX14-BS	250	ZR Balius	'02	YTX7L-BS-N	NTX7L-BS
700	ST 7 Deluxe	'12→'15	YTX14-BS-N	NTX14-BS	250	ZZR	'94→'03	YTX7L-BS-N	NTX7L-BS
ITALJET					300	J	'14→'16	YT12A-BS-N	NT12A-BS
50	Dragster	'98→'12	YB4L-B WA-N	NB4L-B WA	300	J ABS	'14→'20	YT12A-BS-N	NT12A-BS
50	Formula	'96→'03	YB4L-B WA-N	NB4L-B WA	300	KLE Versys-X	'17→'20	YTX9-BS-N	NTX9-BS
50	Formula AIR	'99→'03	YB4L-B WA-N	NB4L-B WA	300	KVF B.Force 2X4	'12→'17	YTX12-BS-N	NTX12-BS
50	Torpedo	'98→'03	YB4L-B WA-N	NB4L-B WA	300	Ninja	'12→'16	YTX9-BS-N	NTX9-BS
50	Velocifero	'98→'02	YB4L-B WA-N	NB4L-B WA	300	Ninja ABS	'12→'16	YTX9-BS-N	NTX9-BS
125	Formula	'96→'03	YB9-B WA-N	NB9-B WA	300	Z ABS	'15→'16	YTX9-BS-N	NTX9-BS
125	Torpedo	'07→'08	YB9-B WA-N	NB9-B WA	300	Z Ninja ABS	'15→'16	YTX9-BS-N	NTX9-BS
100	Millenium	'00→'04	YTX7A-BS-N	NTX7A-BS	400	KFX	'03→'06	YTX9-BS-N	NTX9-BS
125	Millennium	'00→'04	YTX7A-BS-N	NTX7A-BS	400	KLX R	'03→'04	YT7B-BS-N	NT7B-BS
150	Millennium	'00→'04	YTX7A-BS-N	NTX7A-BS	400	KLX SR	'03→'04	YT7B-BS-N	NT7B-BS
KAWASAKI					400	Ninja	'18→'20	YTX9-BS-N	NTX9-BS
50	KFX	'03→'17	YTX5L-BS-N	NTX5L-BS	400	Z ABS	'19→'20	YTX9-BS-N	NTX9-BS
80	KFX	'03→'06	YTX5L-BS-N	NTX5L-BS	400	ZR Xanthus	'92→'95	YTX9-BS-N	NTX9-BS
90	KFX	'07→'17	YTX5L-BS-N	NTX5L-BS	400	ZR Zephyr	'97→'01	YTX12-BS-N	NTX12-BS
110	KLX R	'10→'18	YT4L-BS-N	NT4L-BS	400	ZRX	'94→'96	YTX9-BS-N	NTX9-BS
125	AR	'82→'94	YB5L-B WA-N	NB5L-B WA	400	ZRX	'98→'01	YTX9-BS-N	NTX9-BS
125	BN Eliminator	'98→'07	YB9-B WA-N	NB9-B WA	400	ZXR	'91→'99	YTX9-BS-N	NTX9-BS
125	J	'16→'20	YT12A-BS-N	NT12A-BS	400	ZZR	'93→'99	YTX12-BS-N	NTX12-BS
125	KLX	'03→'06	YTX7L-BS-N	NTX7L-BS	450	KFX R	'08→'14	YTX7L-BS-N	NTX7L-BS
125	KLX	'10→'16	YTX7L-BS-N	NTX7L-BS	450	KLX R	'07→'20	YTZ7S-BS-N	NTZ7S-BS
125	KLX D-Tracker	'10→'14	YTX7L-BS-N	NTX7L-BS	500	EN	'96→'09	YB12AL-A2 WA-N	NB12AL-A2 WA
125	KMX	'86→'92	YB4L-B WA-N	NB4L-B WA	500	ER-5	'97→'07	YTX12-BS-N	NTX12-BS
125	KMX	'95→'95	YB4L-B WA-N	NB4L-B WA	500	GPX R	'88→'90	YTX12-BS-N	NTX12-BS
125	KMX	'98→'99	YB4L-B WA-N	NB4L-B WA	500	GPZ S	'87→'04	YB14L-A2 WA-N	NB14L-A2 WA
125	KMX	'01→'02	YB4L-B WA-N	NB4L-B WA	500	H1 Mach 3	'69→'72	YB9-B WA-N	NB9-B WA
125	NINJA (BX)	'19→'20	YTX7A-BS-N	NTX7A-BS	500	KLE	'91→'07	YTX12-BS-N	NTX12-BS
125	Z	'19→'20	YTX7A-BS-N	NTX7A-BS	500	KLR	'87→'89	YB14L-A2 WA-N	NB14L-A2 WA
200	KMX	'88→'92	YB4L-B WA-N	NB4L-B WA	500	VN Vulcan LTD	'02	YB12AL-A2 WA-N	NB12AL-A2 WA
230	KLX	'20	YTX7A-BS-N	NTX7A-BS	550	ZR Zephyr	'94→'99	YTX12-BS-N	NTX12-BS
250	BJ	'02→'03	YTX9-BS-N	NTX9-BS	600	KLR	'85→'95	YB14L-A2 WA-N	NB14L-A2 WA
250	BJ Estrella	'92→'99	YTX9-BS-N	NTX9-BS	600	ZX-6R	'95→'97	YTX12-BS-N	NTX12-BS
250	BJ Estrella Custom	'96→'02	YTX9-BS-N	NTX9-BS	600	ZX-6R	'98→'01	YTX9-BS-N	NTX9-BS
250	BJ Estrella RS	'99→'02	YTX9-BS-N	NTX9-BS	600	ZX-6R	'07→'16	YTX9-BS-N	NTX9-BS
250	BJ Estrella RS Cust.	'96→'99	YTX9-BS-N	NTX9-BS	600	ZX-6RR	'03→'07	YTX9-BS-N	NTX9-BS
250	EL	'91→'94	YTX7L-BS-N	NTX7L-BS	600	ZZR	'93→'05	YTX12-BS-N	NTX12-BS
250	EL	'96→'97	YTX7L-BS-N	NTX7L-BS	600	ZZR	'06→'07	YTX9-BS-N	NTX9-BS
250	EL	'99	YTX7L-BS-N	NTX7L-BS	636	ZX-6R	'02	YTX9-BS-N	NTX9-BS
250	GPX R	'94→'95	YTX7L-BS-N	NTX7L-BS	636	ZX-6R	'05→'06	YTX9-BS-N	NTX9-BS
250	KL Super Sherpa	'00→'04	YTX7L-BS-N	NTX7L-BS	636	ZX-6R	'13→'15	YTX9-BS-N	NTX9-BS
					636	ZX-6R 30th Ann. Edition	'15	YTX9-BS-N	NTX9-BS

BATTERIE / BATTERY

CC	Modello Model	Anno Years	Vecchio Codice Old Code	Nuovo Codice New Code	CC	Modello Model	Anno Years	Vecchio Codice Old Code	Nuovo Codice New Code
636	ZX-6R 30th Ann. Edition ABS	'15	YTX9-BS-N	NTX9-BS	750	ZXR R	'92-'95	YTX12-BS-N	NTX12-BS
636	ZX-6R ABS	'13-'20	YTX9-BS-N	NTX9-BS	800	VN	'95-'05	YTX14-BS-N	NTX14-BS
636	ZX-6R KRT Ed. ABS	'16-'20	YTX9-BS-N	NTX9-BS	800	VN Classic	'96-'03	YTX14-BS-N	NTX14-BS
636	ZX-6RR	'03-'04	YTX9-BS-N	NTX9-BS	800	VN Classic	'04-'05	YTX12-BS-N	NTX12-BS
650	EN Vulcan S	'15-'17	YTX10S-BS-N	NTZ10S-BS	800	VN Classic	'06-'06	YTX14-BS-N	NTX14-BS
650	EN Vulcan S ABS	'15-'20	YTX10S-BS-N	NTZ10S-BS	800	VN Drifter	'99-'03	YTX14-BS-N	NTX14-BS
650	EN Vulcan S Cafe	'17-'20	YTX10S-BS-N	NTZ10S-BS	800	VN Drifter	'04-'06	YTX12-BS-N	NTX12-BS
650	ER-6F	'12-'16	YTX12A-BS-N	NT12A-BS	800	W	'11-'16	YTX12-BS-N	NTX12-BS
650	ER-6F	'05-'11	YTX12-BS-N	NTX12-BS	800	W	'20	YTX12-BS-N	NTX12-BS
650	ER-6F ABS	'06-'11	YTX12-BS-N	NTX12-BS	800	W Cafe	'19-'20	YTX12-BS-N	NTX12-BS
650	ER-6F ABS	'12-'16	YTX12A-BS-N	NT12A-BS	800	W Cafe Style	'11-'11	YTX12-BS-N	NTX12-BS
650	ER-6N	'06-'11	YTX12-BS-N	NTX12-BS	800	W Special Ed.	'12-'14	YTX12-BS-N	NTX12-BS
650	ER-6N	'12-'16	YTX12A-BS-N	NT12A-BS	800	W Street	'19-'20	YTX12-BS-N	NTX12-BS
650	ER-6N ABS	'06-'11	YTX12-BS-N	NTX12-BS	800	Z	'13-'16	YTX9-BS-N	NTX9-BS
650	ER-6N ABS	'12-'16	YTX12A-BS-N	NT12A-BS	800	Z ABS	'13-'16	YTX9-BS-N	NTX9-BS
650	KL Tengai	'89-'92	YB14L-A2 WA-N	NB14L-A2 WA	800	Z E	'13-'16	YTX9-BS-N	NTX9-BS
650	KLE Versys	'07-'16	YTX12-BS-N	NTX12-BS	800	Z E ABS	'13-'16	YTX9-BS-N	NTX9-BS
650	KLE Versys ABS	'07-'20	YTX12-BS-N	NTX12-BS	800	Z E Special Ed.	'16	YTX9-BS-N	NTX9-BS
650	KLE Versys ABS Tourer	'17-'20	YTX12-BS-N	NTX12-BS	800	Z E Spec. Ed. ABS	'16	YTX9-BS-N	NTX9-BS
650	KLR	'87-'89	YB14L-A2 WA-N	NB14L-A2 WA	900	VN Classic	'06-'19	YTX12-BS-N	NTX12-BS
650	KLR	'95-'14	YB14L-A2 WA-N	NB14L-A2 WA	900	VN Classic LT	'06-'19	YTX12-BS-N	NTX12-BS
650	KLX	'93-'02	YTX9-BS-N	NTX9-BS	900	VN Cl. Special Ed.	'11-'16	YTX12-BS-N	NTX12-BS
650	KVF Brute Force	'09-'14	YTX14-BS-N	NTX14-BS	900	VN Custom	'07-'20	YTX12-BS-N	NTX12-BS
650	KVF B. Force 4X4	'05-'13	YTX14-BS-N	NTX14-BS	900	Z	'73-'76	YB14L-A2 WA-N	NB14L-A2 WA
650	KVF Brute Force H. Green 4X4	'05-'09	YTX14-BS-N	NTX14-BS	900	Z ABS	'17-'20	YTX9-BS-N	NTX9-BS
650	KVF Prairie	'02-'03	YTX14-BS-N	NTX14-BS	900	Z RS	'18-'20	YTX9-BS-N	NTX9-BS
650	Ninja ABS	'17-'20	YTX10S-BS-N	NTZ10S-BS	900	Z RS Cafe	'18-'20	YTX9-BS-N	NTX9-BS
650	Ninja Tourer ABS	'20	YTX10S-BS-N	NTZ10S-BS	900	ZL Eliminator	'85-'86	YB14L-A2 WA-N	NB14L-A2 WA
650	W	'99-'05	YTX14-BS-N	NTX14-BS	900	ZX-9R	'94-'97	YTX12-BS-N	NTX12-BS
650	W	'06-'06	YTX12-BS-N	NTX12-BS	900	ZX-9R	'98-'04	YTX9-BS-N	NTX9-BS
650	Z ABS	'17-'20	YTX10S-BS-N	NTZ10S-BS	1000	GPZ RX	'86-'88	YB14L-A2 WA-N	NB14L-A2 WA
700	KFV KSV V-Force	'04-'11	YTX14-BS-N	NTX14-BS	1000	H2 Ninja	'15-'20	YTX10S-BS-N	NTZ10S-BS
700	KFV Prairie 4X4	'04-'08	YTX14-BS-N	NTX14-BS	1000	H2 Ninja Carbon	'17-'20	YTX10S-BS-N	NTZ10S-BS
700	KFV Team Green	'05-'05	YTX14-BS-N	NTX14-BS	1000	H2 R Ninja	'15-'18	YTX10S-BS-N	NTZ10S-BS
700	VN Vulcan	1985	YB14L-A2 WA-N	NB14L-A2 WA	1000	H2 SE Ninja	'18-'20	YTX10S-BS-N	NTZ10S-BS
700	ZN LTD	'84-'85	YB14L-A2 WA-N	NB14L-A2 WA	1000	H2 SX Ninja	'18-'20	YTX10S-BS-N	NTZ10S-BS
750	GPX R	'87-'90	YB14L-A2 WA-N	NB14L-A2 WA	1000	H2 SX Ninja SE+	'19-'20	YTX10S-BS-N	NTZ10S-BS
750	GPZ R	'85-'87	YB14L-A2 WA-N	NB14L-A2 WA	1000	KLV	'04-'05	YTX14-BS-N	NTX14-BS
750	GPZ Turbo	'83-'87	YB14L-A2 WA-N	NB14L-A2 WA	1000	KLZ Versys	'12-'18	YTX9-BS-N	NTX9-BS
750	GPZ X Unitrak	'83-'87	YB14L-A2 WA-N	NB14L-A2 WA	1000	KLZ Versys	'19-'20	YTX9-BS-N	NTX9-BS
750	GT KZ	'82-'96	YB14L-A2 WA-N	NB14L-A2 WA	1000	KLZ Versys SE	'19-'20	YTX9-BS-N	NTX9-BS
750	KVF Brute Force	'04	YTX14-BS-N	NTX14-BS	1000	NINJA SX	'20	YTX9-BS-N	NTX9-BS
750	KVF Brute Force	'06-'14	YTX14-BS-N	NTX14-BS	1000	Z	'77-'78	YB14L-A2 WA-N	NB14L-A2 WA
750	VN Vulcan	'86-'06	YB14L-A2 WA-N	NB14L-A2 WA	1000	Z	'80-'80	YB14L-A2 WA-N	NB14L-A2 WA
750	Z	'77-'79	YB14L-A2 WA-N	NB14L-A2 WA	1000	Z	'03-'13	YTX9-BS-N	NTX9-BS
750	Z	'04-'13	YTX9-BS-N	NTX9-BS	1000	Z ABS	'07-'13	YTX9-BS-N	NTX9-BS
750	Z ABS	'07-'13	YTX9-BS-N	NTX9-BS	1000	Z ABS	'14-'16	YTX12A-BS-N	NT12A-BS
750	Z R	'11-'12	YTX9-BS-N	NTX9-BS	1000	Z ABS	'17-'20	YTX9-BS-N	NTX9-BS
750	Z R ABS	'11-'12	YTX9-BS-N	NTX9-BS	1000	Z MK2	'79-'80	YB14L-A2 WA-N	NB14L-A2 WA
750	Z R Black Edition	'12	YTX9-BS-N	NTX9-BS	1000	Z R	'17-'20	YTX9-BS-N	NTX9-BS
750	Z S	'05-'07	YTX9-BS-N	NTX9-BS	1000	Z SX	'11-'13	YTX9-BS-N	NTX9-BS
750	Zephyr	'91-'98	YTX12-BS-N	NTX12-BS	1000	Z SX ABS	'14-'16	YTX12A-BS-N	NT12A-BS
750	ZR-7	'99-'04	YTX12-BS-N	NTX12-BS	1000	Z SX ABS	'17-'20	YTX9-BS-N	NTX9-BS
750	ZR-7S	'01-'05	YTX12-BS-N	NTX12-BS	1000	Z Z1R	'78-'79	YB14L-A2 WA-N	NB14L-A2 WA
750	ZX-7R	'96-'03	YTX12-BS-N	NTX12-BS	1000	ZL	'87-'88	YB14L-A2 WA-N	NB14L-A2 WA
750	ZX-7RR	'96-'99	YTX9-BS-N	NTX9-BS	1000	ZX-10	'88-'90	YB14L-A2 WA-N	NB14L-A2 WA
750	ZXR	'89	YB14L-A2 WA-N	NB14L-A2 WA	1000	ZX-10R	'04-'10	YTX12B-BS-N	NT12B-BS
750	ZXR	'90	YB12AL-A2 WA-N	NB12AL-A2 WA	1000	ZX-10R	'11-'15	YTX7S-BS-N	NTZ7S-BS
750	ZXR	'91-'95	YTX12-BS-N	NTX12-BS	1000	ZX-10R 30th Ann. Edition	'15	YTX7S-BS-N	NTZ7S-BS
					1000	ZX-10R ABS	'11-'15	YTX10S-BS-N	NTZ10S-BS
					1000	ZX-10R ABS	'16-'19	YTX10S-BS-N	NTZ10S-BS

BATTERIE / BATTERY

CC	Modello Model	Anno Years	Vecchio Codice Old Code	Nuovo Codice New Code
1000	ZX-10R ABS 30th Ann. Edition	'15	YTZ10S-BS-N	NTZ10S-BS
1000	ZX-10R KRT Rep.	'19→'20	YTZ10S-BS-N	NTZ10S-BS
1000	ZX-10R SE	'18→'20	YTZ10S-BS-N	NTZ10S-BS
1000	ZX-10RR	'17→'18	YTZ10S-BS-N	NTZ10S-BS
1100	GPZ	'95→'99	YTX14-BS-N	NTX14-BS
1100	GPZ ABS	'96→'98	YTX14-BS-N	NTX14-BS
1100	ZRX	'97→'00	YTX14-BS-N	NTX14-BS
1100	ZZR	'90→'92	YB14L-A2 WA-N	NB14L-A2 WA
1100	ZZR	'93→'01	YTX14-BS-N	NTX14-BS
1200	ZRX R	'01→'08	YTX14-BS-N	NTX14-BS
1200	ZRX S	'01→'07	YTX14-BS-N	NTX14-BS
1200	ZX-12R	'00→'06	YTX14-BS-N	NTX14-BS
1200	ZZR	'02→'05	YTX14-BS-N	NTX14-BS
1400	GTR	'08→'15	YTX14-BS-N	NTX14-BS
1400	GTR	'16→'20	YTZ14S-BS-N	NTZ14S-BS
1400	ZZR	'06→'08	YTX14-BS-N	NTX14-BS
1400	ZZR ABS	'06→'20	YTX14-BS-N	NTX14-BS
1400	ZZR Performance Sport ABS	'16→'20	YTX14-BS-N	NTX14-BS

KEEWAY

50	Flash	'07→'09	YTX5L-BS-N	NTX5L-BS
50	Focus	'06→'07	YTX5L-BS-N	NTX5L-BS
50	Hurricane	'07→'14	YTX5L-BS-N	NTX5L-BS
50	Hurricane Base	'07	YTX5L-BS-N	NTX5L-BS
50	Matrix	'06→'12	YTX5L-BS-N	NTX5L-BS
50	RY6	'10→'15	YT4L-BS-N	NT4L-BS
50	RY8	'07→'09	YTX5L-BS-N	NTX5L-BS
50	RY8 Racing	'10→'11	YTX5L-BS-N	NTX5L-BS
50	RY8 SP	'10→'11	YTX5L-BS-N	NTX5L-BS
50	X-RAY SuperM.	'07→'09	YTX5L-BS-N	NTX5L-BS
50	Zahara 2T	'13→'14	YT4L-BS-N	NT4L-BS
50	Zahara 4T	'13→'14	YT4L-BS-N	NT4L-BS
125	Cityblade	'13→'14	YTX7A-BS-N	NTX7A-BS
125	Cityblade	'16→'19	YTX7A-BS-N	NTX7A-BS
125	F-ACT	'07→'11	YTX7L-BS-N	NTX7L-BS
125	Focus	'06→'07	YTX7L-BS-N	NTX7L-BS
125	Logik	'13→'14	YTX7L-BS-N	NTX7L-BS
125	Logik	'17→'19	YTX7L-BS-N	NTX7L-BS
125	Matrix	'06→'10	YTX7L-BS-N	NTX7L-BS
125	Silverblade I	'13→'15	YTX9-BS-N	NTX9-BS
125	Speed	'07→'12	YB9-B WA-N	NB9-B WA
125	Superlight	'07→'15	YTX7A-BS-N	NTX7A-BS
125	Superlight	'17→'19	YTX7A-BS-N	NTX7A-BS
125	Target	'13→'15	YTX5L-BS-N	NTX5L-BS
125	TX SM	'10→'14	YTX7L-BS-N	NTX7L-BS
150	Cityblade	'13→'15	YTX7A-BS-N	NTX7A-BS
150	Logik	'13→'15	YTX7L-BS-N	NTX7L-BS
150	Superlight	'07→'12	YTX7A-BS-N	NTX7A-BS
200	TX	'13→'14	YTX7L-BS-N	NTX7L-BS
250	Blackster	'14→'15	YB9-B WA-N	NB9-B WA
250	Silverblade I	'13→'14	YTX9-BS-N	NTX9-BS

KREIDLER

125	DD Enduro	'08→'11	YTX9-BS-N	NTX9-BS
125	DD Street	'08→'11	YTX9-BS-N	NTX9-BS
125	DD Supermoto	'08→'11	YTX9-BS-N	NTX9-BS
125	Enduro 4T	'14→'15	YTX9-BS-N	NTX9-BS
125	Insignio 4T	'14→'15	YTX9-BS-N	NTX9-BS
125	Supermoto 4T	'14→'15	YTX9-BS-N	NTX9-BS
250	Insignio 4T	'14→'15	YTX9-BS-N	NTX9-BS

CC	Modello Model	Anno Years	Vecchio Codice Old Code	Nuovo Codice New Code
KTM				
125	Duke	'11→'12	YTZ7S-BS-N	NTZ7S-BS
125	Duke ABS	'13→'16	YTZ7S-BS-N	NTZ7S-BS
125	Duke ABS	'17→'20	YTX9-BS-N	NTX9-BS
125	EXE	'00→'01	YT4L-BS-N	NT4L-BS
125	LC2	'96→'98	YT4L-BS-N	NT4L-BS
125	LC2	'96→'98	YT4L-BS-N	NT4L-BS
125	RC	'14→'20	YTX9-BS-N	NTX9-BS
125	SM Supermoto	'00→'01	YT4L-BS-N	NT4L-BS
125	Sting	'97→'98	YT4L-BS-N	NT4L-BS
200	Duke	'12→'14	YTX9-BS-N	NTX9-BS
200	Duke ABS	'13→'20	YTX9-BS-N	NTX9-BS
200	EXC	'13→'16	YT4L-BS-N	NT4L-BS
200	EXC-GS	'02→'02	YT4L-BS-N	NT4L-BS
200	RC	'14→'19	YTX9-BS-N	NTX9-BS
250	Duke	'15→'20	YTX9-BS-N	NTX9-BS
250	EXC	'11→'16	YT4L-BS-N	NT4L-BS
250	EXC E-Starter	'10	YT4L-BS-N	NT4L-BS
250	EXC Factory	'05	YTX5L-BS-N	NTX5L-BS
250	EXC Racing	'01→'06	YTX5L-BS-N	NTX5L-BS
250	EXC Rac. Six Days	'03	YTX5L-BS-N	NTX5L-BS
250	EXC Six Days	'11→'16	YT4L-BS-N	NT4L-BS
250	EXC-F	'06→'07	YTX5L-BS-N	NTX5L-BS
250	EXC-F	'08→'08	YT4L-BS-N	NT4L-BS
250	EXC-F	'09→'11	YTX5L-BS-N	NTX5L-BS
250	EXC-F	'12→'16	YT4L-BS-N	NT4L-BS
250	EXC-F Champ. Ed.	'10	YTX5L-BS-N	NTX5L-BS
250	EXC-F Factory Ed.	'11→'11	YTX5L-BS-N	NTX5L-BS
250	EXC-F Factory Ed.	'15	YT4L-BS-N	NT4L-BS
250	EXC-F Racing	'02→'06	YTX5L-BS-N	NTX5L-BS
250	EXC-F Six Days	'07→'11	YTX5L-BS-N	NTX5L-BS
250	EXC-F Six Days	'12→'16	YT4L-BS-N	NT4L-BS
250	Freeride R	'14→'17	YT4L-BS-N	NT4L-BS
250	RC	'15→'17	YTX9-BS-N	NTX9-BS
250	SX-F	'12→'15	YT4L-BS-N	NT4L-BS
250	XC	'11→'13	YT4L-BS-N	NT4L-BS
250	XC	'14→'14	YTX5L-BS-N	NTX5L-BS
250	XC	'15→'16	YT4L-BS-N	NT4L-BS
250	XC-F	'11→'15	YTX5L-BS-N	NTX5L-BS
300	EXC	'08→'16	YT4L-BS-N	NT4L-BS
300	EXC Factory Ed.	'11	YT4L-BS-N	NT4L-BS
300	EXC Six Days	'09	YT4L-BS-N	NT4L-BS
300	EXC six days	'12→'16	YT4L-BS-N	NT4L-BS
300	EXC-E	'07→'07	YT4L-BS-N	NT4L-BS
300	EXC-E Six Days	'08→'11	YT4L-BS-N	NT4L-BS
300	XC 2T	'11→'17	YT4L-BS-N	NT4L-BS
350	EXC-F	'11→'19	YT4L-BS-N	NT4L-BS
350	EXC-F Six Days	'12→'19	YT4L-BS-N	NT4L-BS
350	Freeride	'12→'16	YTX5L-BS-N	NTX5L-BS
350	SX-F	'10→'15	YT4L-BS-N	NT4L-BS
350	XC-F	'12→'15	YTX5L-BS-N	NTX5L-BS
390	Adventure	'20→'20	YTX9-BS-N	NTX9-BS
390	Duke ABS	'14→'20	YTX9-BS-N	NTX9-BS
390	RC ABS	'14→'20	YTX9-BS-N	NTX9-BS
390	RC R	'18	YTX9-BS-N	NTX9-BS
400	EGS Enduro	'99	YTX9-BS-N	NTX9-BS
400	EGS-E LC4 End.	'97→'97	YTX9-BS-N	NTX9-BS
400	EXC	'09→'11	YTX5L-BS-N	NTX5L-BS
400	EXC Factory Ed.	'11	YTX5L-BS-N	NTX5L-BS
400	EXC Factory Rac.	'05→'07	YTX5L-BS-N	NTX5L-BS
400	EXC Racing	'00→'07	YTX5L-BS-N	NTX5L-BS
400	EXC Rac. Six Days	'01→'03	YTX5L-BS-N	NTX5L-BS

BATTERIE / BATTERY

CC	Modello Model	Anno Years	Vecchio Codice Old Code	Nuovo Codice New Code	CC	Modello Model	Anno Years	Vecchio Codice Old Code	Nuovo Codice New Code
400	LC4	'98→'99	YTX9-BS-N	NTX9-BS	640	LC4 Supermoto	'99	YTX9-BS-N	NTX9-BS
400	LC4 R Enduro	'99	YTX9-BS-N	NTX9-BS	640	LC4 Supermoto	'03→'06	YTZ10S-BS-N	NTZ10S-BS
400	LC4-E	'00→'01	YTX9-BS-N	NTX9-BS	640	LC4 Supermoto	'03→'06	YTZ10S-BS-N	NTZ10S-BS
400	LSE	'96→'97	YTX9-BS-N	NTX9-BS		Prestige			
450	EXC	'06	YTX5L-BS-N	NTX5L-BS	640	LC4-E Enduro	'00→'01	YTX9-BS-N	NTX9-BS
450	EXC	'09→'16	YTX5L-BS-N	NTX5L-BS	640	LC4-E Enduro	'02	YTZ10S-BS-N	NTZ10S-BS
450	EXC Champ. Ed.	'10	YTX5L-BS-N	NTX5L-BS	640	LC4-E Six Days	'02	YTX9-BS-N	NTX9-BS
450	EXC Factory	'05	YTX5L-BS-N	NTX5L-BS	640	LC4-E Supermoto	'00→'02	YTX9-BS-N	NTX9-BS
450	EXC Factory Rac.	'07	YTX5L-BS-N	NTX5L-BS	640	SMC LC4	'05	YTZ10S-BS-N	NTZ10S-BS
450	EXC Racing	'03→'07	YTX5L-BS-N	NTX5L-BS	660	LC4 Rally	'99→'00	YTX5L-BS-N	NTX5L-BS
450	EXC Rac. Six Days	'04→'07	YTX5L-BS-N	NTX5L-BS	660	LC4 Rally	'01→'02	YTX9-BS-N	NTX9-BS
450	EXC Six Days	'09→'16	YTX5L-BS-N	NTX5L-BS	660	Rally Factory Rep.	'03→'07	YTZ10S-BS-N	NTZ10S-BS
450	EXC-R	'08	YTX5L-BS-N	NTX5L-BS	690	Duke	'08→'12	YTZ10S-BS-N	NTZ10S-BS
450	EXC-R SIX Days	'08	YTX5L-BS-N	NTX5L-BS	690	Duke ABS	'12→'17	YTZ10S-BS-N	NTZ10S-BS
450	Rally Factory Rep.	'11→'13	YT4L-BS-N	NT4L-BS	690	Duke ABS	'18→'19	YT12B-BS-N	NT12B-BS
450	SMR	'08→'14	YT4L-BS-N	NT4L-BS	690	Duke R	'10→'12	YTZ10S-BS-N	NTZ10S-BS
450	SX Quad	'08→'10	YTX5L-BS-N	NTX5L-BS	690	Duke R ABS	'13→'18	YTZ10S-BS-N	NTZ10S-BS
450	SX-F	'07→'07	YT4L-BS-N	NT4L-BS	690	Enduro	'08→'10	YTZ10S-BS-N	NTZ10S-BS
450	SX-F	'08→'10	YTX5L-BS-N	NTX5L-BS	690	Enduro R	'09→'13	YTZ10S-BS-N	NTZ10S-BS
450	SX-F	'11→'15	YT4L-BS-N	NT4L-BS	690	Enduro R ABS	'14→'20	YTZ10S-BS-N	NTZ10S-BS
450	XC Quad	'07→'10	YTX5L-BS-N	NTX5L-BS	690	Rally Factory Rep.	'07→'10	YTZ10S-BS-N	NTZ10S-BS
450	XC-F	'08→'09	YTX5L-BS-N	NTX5L-BS	690	SMC	'08→'11	YTZ10S-BS-N	NTZ10S-BS
450	XC-F	'13→'20	YTX5L-BS-N	NTX5L-BS	690	SMC R	'12→'13	YTZ10S-BS-N	NTZ10S-BS
500	EXC	'12→'19	YTX5L-BS-N	NTX5L-BS	690	SMC R ABS	'14→'20	YTZ10S-BS-N	NTZ10S-BS
500	EXC Six Days	'12→'19	YTX5L-BS-N	NTX5L-BS	690	Supermoto	'07→'10	YTZ10S-BS-N	NTZ10S-BS
505	SX Quad	'08→'13	YTX5L-BS-N	NTX5L-BS	690	SuperM. Lim. Ed.	'09	YTZ10S-BS-N	NTZ10S-BS
505	SX-F	'07→'07	YTX5L-BS-N	NTX5L-BS	690	SuperM. Prestige	'07	YTZ10S-BS-N	NTZ10S-BS
505	XC-F	'09	YTX5L-BS-N	NTX5L-BS	690	Supermoto R	'08	YTZ10S-BS-N	NTZ10S-BS
520	EXC Racing	'00→'02	YTX5L-BS-N	NTX5L-BS	950	Adventure	'02→'05	YTZ14S-BS-N	NTZ14S-BS
520	EXC Rac. Six Days	'01→'02	YTX5L-BS-N	NTX5L-BS	950	Adventure S	'03→'06	YTZ14S-BS-N	NTZ14S-BS
525	EXC Factory	'05	YTX5L-BS-N	NTX5L-BS	950	Super Enduro R	'06→'08	YTZ14S-BS-N	NTZ14S-BS
525	EXC Factory Rac.	'07	YTX5L-BS-N	NTX5L-BS	950	Supermoto	'05→'08	YTZ14S-BS-N	NTZ14S-BS
525	EXC Racing	'03→'07	YTX5L-BS-N	NTX5L-BS	950	Supermoto R	'07→'08	YTZ14S-BS-N	NTZ14S-BS
525	EXC Rac. Six Days	'03→'07	YTX5L-BS-N	NTX5L-BS	990	Adventure ABS	'06→'12	YTZ14S-BS-N	NTZ14S-BS
525	MXC Desert Rac.	'03→'05	YTX5L-BS-N	NTX5L-BS	990	Adventure Dakar	'11	YTZ14S-BS-N	NTZ14S-BS
525	XC Desert Racing	'04→'07	YTX5L-BS-N	NTX5L-BS		Edition ABS			
525	XC Quad	'08→'12	YTX5L-BS-N	NTX5L-BS	990	Adventure Limited	'10	YTZ14S-BS-N	NTZ14S-BS
530	EXC	'09→'11	YTX5L-BS-N	NTX5L-BS		Edition ABS			
530	EXC Factory Ed.	'11	YTX5L-BS-N	NTX5L-BS	990	Adventure R	'09→'12	YTZ14S-BS-N	NTZ14S-BS
530	EXC Six Days	'09→'12	YTX5L-BS-N	NTX5L-BS	990	Adventure S	'06→'08	YTZ14S-BS-N	NTZ14S-BS
530	EXC-R	'08	YTX5L-BS-N	NTX5L-BS	990	Super Duke	'05→'12	YTZ14S-BS-N	NTZ14S-BS
530	EXC-R Six Days	'08	YTX5L-BS-N	NTX5L-BS	990	Super Duke R	'07→'13	YTZ14S-BS-N	NTZ14S-BS
620	Duke	'93→'99	YTX9-BS-N	NTX9-BS	990	Supermoto	'08→'10	YTZ14S-BS-N	NTZ14S-BS
620	EGS	'98→'99	YTX9-BS-N	NTX9-BS	990	Supermoto R	'09→'12	YTZ14S-BS-N	NTZ14S-BS
620	EGS-E	'97	YTX9-BS-N	NTX9-BS	990	Supermoto R ABS	'12→'13	YTZ14S-BS-N	NTZ14S-BS
620	EGS-E Adventure	'97	YTX9-BS-N	NTX9-BS	990	Supermoto T	'09→'10	YTZ14S-BS-N	NTZ14S-BS
620	GS XC LC4	'94→'99	YTX9-BS-N	NTX9-BS	990	Supermoto T ABS	'11→'13	YTZ14S-BS-N	NTZ14S-BS
620	LC4 Competition	'99	YTX9-BS-N	NTX9-BS	1050	Adventure ABS	'15→'16	YTZ14S-BS-N	NTZ14S-BS
620	LC4 Super Comp.	'98	YTX9-BS-N	NTX9-BS	1090	Adventure	'17→'19	YTZ14S-BS-N	NTZ14S-BS
620	LC4 Supermoto	'99	YTX9-BS-N	NTX9-BS	1090	Adventure R	'17→'19	YTZ14S-BS-N	NTZ14S-BS
625	SMC	'04→'06	YTZ10S-BS-N	NTZ10S-BS	1090	Adventure S	'19	YTZ14S-BS-N	NTZ14S-BS
625	SXC	'03→'07	YTZ10S-BS-N	NTZ10S-BS	1190	Adventure ABS	'13→'16	YTZ14S-BS-N	NTZ14S-BS
640	Adventure	'05→'07	YTZ10S-BS-N	NTZ10S-BS	1190	Adventure R ABS	'13→'16	YTZ14S-BS-N	NTZ14S-BS
640	Adventure R	'98→'02	YTX9-BS-N	NTX9-BS	1190	RC8	'08→'11	YTZ14S-BS-N	NTZ14S-BS
640	Adventure R	'03→'04	YTZ10S-BS-N	NTZ10S-BS	1190	RC8 R	'09→'16	YTZ14S-BS-N	NTZ14S-BS
640	Duke II	'98→'02	YTX9-BS-N	NTX9-BS	1190	RC8 R Track	'11→'13	YTZ14S-BS-N	NTZ14S-BS
640	Duke II	'03→'07	YTZ10S-BS-N	NTZ10S-BS	1290	Super Adventure	'15→'17	YTZ14S-BS-N	NTZ14S-BS
640	LC4 Adventure	'03→'06	YTZ10S-BS-N	NTZ10S-BS	1290	Super Adv. R	'17→'20	YTZ14S-BS-N	NTZ14S-BS
640	LC4 Enduro	'98→'99	YTX9-BS-N	NTX9-BS	1290	Super Adv. S	'17→'20	YTZ14S-BS-N	NTZ14S-BS
640	LC4 Enduro	'00→'06	YTZ10S-BS-N	NTZ10S-BS	1290	Super Adv. T	'17	YTZ14S-BS-N	NTZ14S-BS
640	LC4 Six Days	'99	YTX9-BS-N	NTX9-BS	1290	Super Duke GT	'17→'20	YTZ14S-BS-N	NTZ14S-BS

BATTERIE / BATTERY

CC	Modello Model	Anno Years	Vecchio Codice Old Code	Nuovo Codice New Code	CC	Modello Model	Anno Years	Vecchio Codice Old Code	Nuovo Codice New Code
1290	Super Duke R	'14→'19	YTX14-BS-N	NTX14-BS	50	SR Active	'08→'11	YTX5L-BS-N	NTX5L-BS
1290	Super Duke R	'18→'20	YTZ14S-BS-N	NTZ14S-BS	50	Super 8	'07→'16	YTX7A-BS-N	NTX7A-BS
1290	Super Duke R SE	'16→'17	YTX14-BS-N	NTX14-BS	50	Super 8	'07→'16	YTX7A-BS-N	NTX7A-BS
KYMCO					50	Top Boy	'97→'06	YTX5L-BS-N	NTX5L-BS
50	AC Super 9	'00→'07	YT4L-BS-N	NT4L-BS	50	Vitality	'04→'09	YTX5L-BS-N	NTX5L-BS
50	AC Sup. 9 Sports	'06→'13	YT4L-BS-N	NT4L-BS	50	Vitality Cross	'07→'09	YTX5L-BS-N	NTX5L-BS
50	Activ	'05→'06	YB5L-B WA-N	NB5L-B WA	50	Yager	'98→'06	YTX5L-BS-N	NTX5L-BS
50	Agility	'05	YTX5L-BS-N	NTX5L-BS	50	Yager	'07	YTX5L-BS-N	NTX5L-BS
50	Agility	'08→'16	YTX7A-BS-N	NTX7A-BS	50	YUP	'02→'09	YT4L-BS-N	NT4L-BS
50	Agility +	'08→'17	YTX7A-BS-N	NTX7A-BS	50	ZX Scout	'99→'06	YTX5L-BS-N	NTX5L-BS
50	Agility Carry	'11→'16	YTX7A-BS-N	NTX7A-BS	50	ZX Super Fever	'99→'06	YTX5L-BS-N	NTX5L-BS
50	Agility RS	'10→'14	YTX5L-BS-N	NTX5L-BS	90	KXR Mongoose	'04→'15	YTX5L-BS-N	NTX5L-BS
50	Agility RS Naked	'10→'14	YTX5L-BS-N	NTX5L-BS	90	Maxxer	'05→'16	YTX5L-BS-N	NTX5L-BS
50	Bet & Win	'01→'06	YTX5L-BS-N	NTX5L-BS	100	AS	'99	YTX5L-BS-N	NTX5L-BS
50	Calypso	'99	YTX5L-BS-N	NTX5L-BS	100	Cobra Racer	'99→'03	YTX5L-BS-N	NTX5L-BS
50	Cobra	'00→'06	YTX5L-BS-N	NTX5L-BS	100	KB Manboy	'97→'00	YTX5L-BS-N	NTX5L-BS
50	Cobra Racer	'00→'06	YTX5L-BS-N	NTX5L-BS	100	Top Boy	'97	YTX7A-BS-N	NTX7A-BS
50	CX	'93	YT4L-BS-N	NT4L-BS	125	Agility	'06→'14	YTX7A-BS-N	NTX7A-BS
50	CX Super	'94→'97	YT4L-BS-N	NT4L-BS	125	Agility	'08→'15	YTX7A-BS-N	NTX7A-BS
50	Dink	'98→'02	YTX5L-BS-N	NTX5L-BS	125	Agility +	'14→'16	YTX7A-BS-N	NTX7A-BS
50	Dink	'07→'08	YTX5L-BS-N	NTX5L-BS	125	Agility Carry	'11→'16	YTX7A-BS-N	NTX7A-BS
50	Dink	'09	YTX7A-BS-N	NTX7A-BS	125	Agility One	'09	YTX7A-BS-N	NTX7A-BS
50	Dink	'10→'14	YTX5L-BS-N	NTX5L-BS	125	Agility RS	'10→'15	YTX7A-BS-N	NTX7A-BS
50	Dink Cl. Euro 2	'03	YTX5L-BS-N	NTX5L-BS	125	Bet & Win	'00→'06	YTX9-BS-N	NTX9-BS
50	Dink Sports	'02→'06	YTX5L-BS-N	NTX5L-BS	125	Calypso	'99	YTX5L-BS-N	NTX5L-BS
50	DJ S	'12→'15	YTX7A-BS-N	NTX7A-BS	125	CK Pulsar	'04→'05	YTX7A-BS-N	NTX7A-BS
50	DJW World	'95→'97	YT4L-BS-N	NT4L-BS	125	Cruiser	'99	YTX7A-BS-N	NTX7A-BS
50	DJX	'91→'92	YT4L-BS-N	NT4L-BS	125	Dink	'97	YTX9-BS-N	NTX9-BS
50	DJY Refined	'93→'06	YT4L-BS-N	NT4L-BS	125	Dink Classic	'02	YTX9-BS-N	NTX9-BS
50	Filly	'98→'00	YTX5L-BS-N	NTX5L-BS	125	Dink I	'06→'15	YTX9-BS-N	NTX9-BS
50	Filly LX	'00→'06	YTX5L-BS-N	NTX5L-BS	125	Dink LX	'98→'00	YTX9-BS-N	NTX9-BS
50	Grand Dink	'04→'16	YT4L-BS-N	NT4L-BS	125	Dink/Spacer	'97→'04	YTX9-BS-N	NTX9-BS
50	Grand Dink S	'08→'13	YT4L-BS-N	NT4L-BS	125	DJ S	'12→'16	YTX7A-BS-N	NTX7A-BS
50	Heroism	'95→'97	YT4L-BS-N	NT4L-BS	125	Downtown I	'09→'11	YT12A-BS-N	NT12A-BS
50	K12 Sport	'95→'00	YT4L-BS-N	NT4L-BS	125	Downtown I ABS	'12→'19	YT12A-BS-N	NT12A-BS
50	KB	'95→'00	YT4L-BS-N	NT4L-BS	125	G-Dink I	'12→'16	YTX9-BS-N	NTX9-BS
50	K-Pipe	'12→'13	YTX5L-BS-N	NTX5L-BS	125	Grand Dink	'01→'08	YTX9-BS-N	NTX9-BS
50	KPW	'13→'14	YTX7A-BS-N	NTX7A-BS	125	Grand Dink S	'09→'15	YTX9-BS-N	NTX9-BS
50	LC Super 9	'00→'07	YTX5L-BS-N	NTX5L-BS	125	Grand Dink/Miler	'01→'07	YTX9-BS-N	NTX9-BS
50	Like	'09→'16	YTX7A-BS-N	NTX7A-BS	125	Heroism	'95→'96	YTX9-BS-N	NTX9-BS
50	Like	'09→'16	YTX7A-BS-N	NTX7A-BS	125	Hipster	'99→'05	YTX7A-BS-N	NTX7A-BS
50	Like	'14→'14	YTX5L-BS-N	NTX5L-BS	125	Hipster	'06→'07	YTX7A-BS-N	NTX7A-BS
50	Like	'17→'20	YTX7A-BS-N	NTX7A-BS	125	K-Pipe	'12→'15	YTX7A-BS-N	NTX7A-BS
50	Like Euro 4	'18	YTX7A-BS-N	NTX7A-BS	125	KR Quan. Naked	'10→'15	YT7B-BS-N	NT7B-BS
50	Looker	'07→'08	YTX5L-BS-N	NTX5L-BS	125	KR Quan. Sport	'07→'13	YT7B-BS-N	NT7B-BS
50	Looping	'98	YTX5L-BS-N	NTX5L-BS	125	K-XCT I	'12→'15	YTX9-BS-N	NTX9-BS
50	LX Like	'14→'16	YTX7A-BS-N	NTX7A-BS	125	Like	'09→'16	YTX7A-BS-N	NTX7A-BS
50	Maxxer	'06	YTX5L-BS-N	NTX5L-BS	125	Like LX	'09→'16	YTX7A-BS-N	NTX7A-BS
50	Maxxer Quad	'05→'16	YTX5L-BS-N	NTX5L-BS	125	Movie	'99→'00	YTX9-BS-N	NTX9-BS
50	MXER Quad	'00→'07	YTX5L-BS-N	NTX5L-BS	125	Movie I	'12→'13	YTX9-BS-N	NTX9-BS
50	MXU Quad	'04→'13	YTX9-BS-N	NTX9-BS	125	MXER Quad	'02→'07	YTX9-BS-N	NTX9-BS
50	MXU Rev. Quad	'07→'16	YTX9-BS-N	NTX9-BS	125	People	'99→'14	YTX7A-BS-N	NTX7A-BS
50	NEW Sento I	'12→'16	YTX7A-BS-N	NTX7A-BS	125	People GT I	'10→'14	YT12A-BS-N	NT12A-BS
50	Nexxon	'08→'09	YTX5L-BS-N	NTX5L-BS	125	People One I	'13→'16	YTX7A-BS-N	NTX7A-BS
50	People	'99→'16	YTX5L-BS-N	NTX5L-BS	125	People One I DD CBS E4	'16→'19	YTX7A-BS-N	NTX7A-BS
50	People S	'05→'15	YTX5L-BS-N	NTX5L-BS	125	People S DD	'07→'10	YTX7A-BS-N	NTX7A-BS
50	People S	'06→'15	YTX7A-BS-N	NTX7A-BS	125	People S I	'17→'19	YT9B-BS-N	NT9B-BS
50	People S Elegance	'14→'15	YTX7A-BS-N	NTX7A-BS	125	People S	'05→'15	YTX7A-BS-N	NTX7A-BS
50	Sento	'08→'16	YTX5L-BS-N	NTX5L-BS	125	Spacer	'97→'99	YTX9-BS-N	NTX9-BS
50	Sniper	'93→'96	YT4L-BS-N	NT4L-BS	125	Stryker	'01→'06	YTX7A-BS-N	NTX7A-BS
50	Spacer	'98→'10	YTX5L-BS-N	NTX5L-BS	125	Super 8	'08→'16	YTX7A-BS-N	NTX7A-BS

BATTERIE / BATTERY

CC	Modello Model	Anno Years	Vecchio Codice Old Code	Nuovo Codice New Code	CC	Modello Model	Anno Years	Vecchio Codice Old Code	Nuovo Codice New Code
125	Super Dink I	'09→'14	YTX9-BS-N	NTX9-BS	350	Downtown I	'15→'16	YT12A-BS-N	NT12A-BS
125	Visar	'11→'15	YB9-B WA-N	NB9-B WA	350	Downtown I	'19→'19	YT12A-BS-N	NT12A-BS
125	Vivio	'00	YTX9-BS-N	NTX9-BS	350	Downtown I (Exclusive) ABS	'15→'19	YT12A-BS-N	NT12A-BS
125	Vivio	'01→'03	YTX9-BS-N	NTX9-BS	350	Downtown I (Exclusive) TCS	'18	YT12A-BS-N	NT12A-BS
125	XL Movie	'01→'09	YTX9-BS-N	NTX9-BS	400	Maxxer	'09→'10	YTX14-BS-N	NTX14-BS
125	XL Movie	'12	YTX9-BS-N	NTX9-BS	400	Xciting I	'12→'15	YTX14-BS-N	NTX14-BS
125	X-Town I ABS	'16→'19	YT12A-BS-N	NT12A-BS	400	Xciting I ABS	'15→'20	YTX14-BS-N	NTX14-BS
125	Yager GT	'07→'13	YTX9-BS-N	NTX9-BS	400	Xciting I S ABS	'17→'20	YT12A-BS-N	NT12A-BS
125	Zing Custom Style	'97→'06	YTX7A-BS-N	NTX7A-BS	500	Xciting	'05→'05	YTX14-BS-N	NTX14-BS
125	Zing II Cust. Style	'07→'16	YTX7A-BS-N	NTX7A-BS	500	Xciting I	'06→'08	YTX14-BS-N	NTX14-BS
125	Zing II Dark Side	'16→'17	YTX7A-BS-N	NTX7A-BS	500	Xciting I EVO ABS	'13	YTX14-BS-N	NTX14-BS
150	Agility	'08→'12	YTX7A-BS-N	NTX7A-BS	500	Xciting I R	'07→'16	YTX14-BS-N	NTX14-BS
150	Agility I +	'17→'18	YTX9-BS-N	NTX9-BS	700	MY Road I	'11→'16	YTX14-BS-N	NTX14-BS
150	Bet & Win	'01→'06	YTX9-BS-N	NTX9-BS	LAVERDA				
150	Dink Classic	'02	YTX9-BS-N	NTX9-BS	150	Phoenix	'01→'04	YTX9-BS-N	NTX9-BS
150	Dink LX	'98→'00	YTX9-BS-N	NTX9-BS	200	Phoenix	'01→'04	YTX9-BS-N	NTX9-BS
150	Dink/Spacer	'97→'04	YTX9-BS-N	NTX9-BS	650	Formula	'94→'95	YB14L-A2 WA-N	NB14L-A2 WA
150	Grand Dink	'08→'11	YTX9-BS-N	NTX9-BS	650	Ghost	'96→'97	YB14L-A2 WA-N	NB14L-A2 WA
150	Grand Dink/Miler	'01→'07	YTX9-BS-N	NTX9-BS	650	Legend	'97	YB14L-A2 WA-N	NB14L-A2 WA
150	Heroism	'95→'97	YTX9-BS-N	NTX9-BS	650	Sport	'95→'96	YB14L-A2 WA-N	NB14L-A2 WA
150	Movie XL	'01→'09	YTX9-BS-N	NTX9-BS	650	Strike	'97	YB14L-A2 WA-N	NB14L-A2 WA
150	MXER Quad	'02→'07	YTX9-BS-N	NTX9-BS	668	668	'96→'97	YB14L-A2 WA-N	NB14L-A2 WA
150	MXU Quad	'05→'16	YTX9-BS-N	NTX9-BS	668	668 Ghost	'98→'99	YB14L-A2 WA-N	NB14L-A2 WA
150	People	'99→'04	YTX7A-BS-N	NTX7A-BS	668	668 Ghost Strike	'98→'99	YB14L-A2 WA-N	NB14L-A2 WA
150	People S I	'17→'19	YT9B-BS-N	NT9B-BS	750	Formula	'98→'99	YB4L-B WA-N	NB4L-B WA
150	Stryker	'00→'06	YTX7A-BS-N	NTX7A-BS	750	S	'98→'99	YB4L-B WA-N	NB4L-B WA
150	Vivio	'00→'03	YTX9-BS-N	NTX9-BS	750	S Formula	'00→'01	YB4L-B WA-N	NB4L-B WA
150	Zing Custom Style	'97→'13	YTX7A-BS-N	NTX7A-BS	1000	RGA	'83	Y60-N30L-A WA-N	N60-N30L-A WA
200	Agility I	'10→'15	YTX9-BS-N	NTX9-BS	1000	RGS	'82	Y60-N30L-A WA-N	N60-N30L-A WA
200	Agility I +	'10→'15	YTX9-BS-N	NTX9-BS	1000	RGS	'83	Y60-N30L-A WA-N	N60-N30L-A WA
200	Dink Classic	'03→'04	YTX9-BS-N	NTX9-BS	1000	RGS Corsa	'84→'85	Y60-N30L-A WA-N	N60-N30L-A WA
200	Dink I	'06→'15	YT12A-BS-N	NT12A-BS	1200	1200	'78→'79	Y60-N30L-A WA-N	N60-N30L-A WA
200	Downtown I	'10→'15	YT12A-BS-N	NT12A-BS	1200	TS Mirage	'81	Y60-N30L-A WA-N	N60-N30L-A WA
200	Like I	'09→'15	YTX9-BS-N	NTX9-BS	MALAGUTI				
200	People S	'05→'08	YTX7A-BS-N	NTX7A-BS	50	Centro Base	'93→'94	YB4L-B WA-N	NB4L-B WA
200	People S I DD	'07→'14	YTZ10S-BS-N	NTZ10S-BS	50	Centro SL	'94→'00	YB5L-B WA-N	NB5L-B WA
200	Yager I	'07→'13	YT12A-BS-N	NT12A-BS	50	Centro SL 4T	'08→'11	YB5L-B WA-N	NB5L-B WA
250	Bet & Win	'00→'06	YTX12-BS-N	NTX12-BS	50	Ciak	'00→'03	YB5L-B WA-N	NB5L-B WA
250	Grand Dink	'01→'06	YTX12-BS-N	NTX12-BS	50	Ciak	'00→'04	YB5L-B WA-N	NB5L-B WA
250	KXR Mongoose	'04→'07	YTX12-BS-N	NTX12-BS	50	Ciak Master 4T	'04→'08	YB5L-B WA-N	NB5L-B WA
250	Maxxer	'07→'16	YTX12-BS-N	NTX12-BS	50	Crosser CR1	'95→'98	YB4L-B WA-N	NB4L-B WA
250	MXU	'04→'13	YTX12-BS-N	NTX12-BS	50	Enduro Dune	'87	YB4L-B WA-N	NB4L-B WA
250	People	'03→'06	YTX12-BS-N	NTX12-BS	50	F10 Jetline	'91→'10	YB4L-B WA-N	NB4L-B WA
250	People SI DD	'07→'08	YTX12-BS-N	NTX12-BS	50	F10 Tribal	'08→'10	YB4L-B WA-N	NB4L-B WA
250	Urban Quad	'06	YTX12-BS-N	NTX12-BS	50	F10 WAP	'10→'11	YB4L-B WA-N	NB4L-B WA
250	Venox	'00→'06	YTX9-BS-N	NTX9-BS	50	F12 Phantom	'94→'03	YB4L-B WA-N	NB4L-B WA
250	Xciting	'05	YTX12-BS-N	NTX12-BS	50	F12 Phantom	'94→'98	YB4L-B WA-N	NB4L-B WA
250	Xciting I	'06→'08	YTX12-BS-N	NTX12-BS	50	F12 Phantom	'98→'03	YB4L-B WA-N	NB4L-B WA
250	YUP	'03→'06	YTX12-BS-N	NTX12-BS	50	F12 Phantom AC	'02→'08	YB4L-B WA-N	NB4L-B WA
300	Downtown I	'09→'13	YT12A-BS-N	NT12A-BS	50	F12 Phantom LC	'00→'08	YB4L-B WA-N	NB4L-B WA
300	Downtown I ABS	'10→'16	YT12A-BS-N	NT12A-BS	50	F12 R Ph. AC	'07→'11	YB4L-B WA-N	NB4L-B WA
300	G-Dink I	'12→'16	YT12A-BS-N	NT12A-BS	50	F12 R Ph. LC	'07→'11	YB4L-B WA-N	NB4L-B WA
300	Grand Dink I	'19→'20	YT12A-BS-N	NT12A-BS	50	F15 Firefox	'96→'00	YB4L-B WA-N	NB4L-B WA
300	K-XCT I	'12→'16	YT12A-BS-N	NT12A-BS	50	F15 Firefox	'98	YB4L-B WA-N	NB4L-B WA
300	Maxxer	'05→'16	YTX12-BS-N	NTX12-BS	50	F15 Firefox	'98	YB4L-B WA-N	NB4L-B WA
300	MXU	'06→'11	YTX12-BS-N	NTX12-BS	50	F15 Firefox AC	'99→'08	YB4L-B WA-N	NB4L-B WA
300	People GT I	'10→'16	YT12A-BS-N	NT12A-BS	50	F15 Firefox LC	'01→'08	YB4L-B WA-N	NB4L-B WA
300	People GT I ABS	'14→'19	YT12A-BS-N	NT12A-BS	50	Fifty EvolutionN	'91→'94	YB4L-B WA-N	NB4L-B WA
300	People S I	'08→'10	YT12A-BS-N	NT12A-BS					
300	Xciting I	'08→'11	YTX12-BS-N	NTX12-BS					
300	Xciting R I	'08→'14	YTX12-BS-N	NTX12-BS					
300	X-Town I ABS	'19	YTX12-BS-N	NTX12-BS					

BATTERIE / BATTERY

CC	Modello Model	Anno Years	Vecchio Codice Old Code	Nuovo Codice New Code	CC	Modello Model	Anno Years	Vecchio Codice Old Code	Nuovo Codice New Code
50	NKD Drakon	'05→'09	YT4L-BS-N	NT4L-BS	100	Booster	'99→'02	YTX5L-BS-N	NTX5L-BS
50	RCW4 Grizzly	'01→'07	YB4L-B WA-N	NB4L-B WA	100	Ovetto	'99→'02	YT4L-BS-N	NT4L-BS
50	RCX 10 Grizzly	'90→'00	YB4L-B WA-N	NB4L-B WA	125	Cityliner	'08→'13	YTX9-BS-N	NTX9-BS
50	RCX 12 Grizzly	'90→'00	YB4L-B WA-N	NB4L-B WA	125	Flame X	'04→'12	YTX7A-BS-N	NTX7A-BS
50	RV Fifty	'90→'00	YB4L-B WA-N	NB4L-B WA	125	Flame XC	'96→'03	YTX7A-BS-N	NTX7A-BS
50	XSM SuperM.	'03→'11	YB4L-B WA-N	NB4L-B WA	125	Flame XC T	'95→'96	YTX7A-BS-N	NTX7A-BS
50	XTM	'03→'11	YB4L-B WA-N	NB4L-B WA	125	Skycruiser	'06→'13	YTX9-BS-N	NTX9-BS
50	Yesterday	'98→'03	YB4L-B WA-N	NB4L-B WA	125	Skyliner	'98→'02	YB7L-B2 WA-N	NB7L-B2 WA
100	Ciak	'99→'03	YB5L-B WA-N	NB5L-B WA	125	Thunder	'01→'03	YB7L-B2 WA-N	NB7L-B2 WA
100	F12 Phantom	'99→'03	YTX5L-BS-N	NTX5L-BS	125	Waap	'08→'10	YTX7A-BS-N	NTX7A-BS
125	Ciak	'00→'01	YB9-B WA-N	NB9-B WA	125	YW Z X-Over	'10	YT9B-BS-N	NT9B-BS
125	Ciak Master	'02→'11	YB9-B WA-N	NB9-B WA	150	Doodo	'00→'05	YB7L-B2 WA-N	NB7L-B2 WA
125	F18 Project	'00→'01	YB9-B WA-N	NB9-B WA	150	Thunder	'01→'03	YB7L-B2 WA-N	NB7L-B2 WA
125	F18 Warrior	'00→'02	YB9-B WA-N	NB9-B WA	150	Vertex	'97→'97	YTX7A-BS-N	NTX7A-BS
125	Madison	'99→'01	YB9-B WA-N	NB9-B WA	250	Skyliner	'96→'02	YT7B-BS-N	NT7B-BS
125	Madison 3	'07→'12	YB9-B WA-N	NB9-B WA	300	Kilibre	'03→'04	YTX9-BS-N	NTX9-BS
125	madison R	'03→'07	YB9-B WA-N	NB9-B WA	400	Skyliner	'04	YT9B-BS-N	NT9B-BS
125	X3M Enduro	'08→'10	YTX7L-BS-N	NTX7L-BS	MH/MOTOR HISPANIA				
125	X3M Motard	'08→'10	YTX7L-BS-N	NTX7L-BS	50	RX	'05→'07	YT4L-BS-N	NT4L-BS
150	Ciak	'00→'01	YB9-B WA-N	NB9-B WA	50	RX R	'08→'14	YTX5L-BS-N	NTX5L-BS
150	Ciak Master	'02→'06	YB9-B WA-N	NB9-B WA	50	RYZ Enduro	'06→'14	YT4L-BS-N	NT4L-BS
150	F18 Project	'00→'02	YB9-B WA-N	NB9-B WA	50	RYZ PRO Racing	'06→'14	YT4L-BS-N	NT4L-BS
150	F18 Warrior	'00→'03	YB9-B WA-N	NB9-B WA	Enduro				
150	Madison	'99→'03	YB9-B WA-N	NB9-B WA	50	RYZ PRO Racing	'06→'14	YT4L-BS-N	NT4L-BS
180	Madison	'02→'04	YB9-B WA-N	NB9-B WA	Supermotard				
180	Madison R	'02	YB9-B WA-N	NB9-B WA	50	RYZ PRO Racing	'06→'10	YT4L-BS-N	NT4L-BS
250	F12 Phatom Max	'05→'06	YTX12-BS-N	NTX12-BS	Urban Bike				
250	Madison 3 IE	'06→'12	YB9-B WA-N	NB9-B WA	50	RYZ Supermotard	05→'10	YT4L-BS-N	NT4L-BS
250	Madison RS	'03→'06	YB9-B WA-N	NB9-B WA	50	RYZ Urban Bike	'06→'10	YT4L-BS-N	NT4L-BS
250	Madison S	'99→'03	YB9-B WA-N	NB9-B WA	MOTO GUZZI				
250	Password	'05→'11	YTX12-BS-N	NTX12-BS	350	Nevada Club	'98→'99	Y60-N30L-A WA-N	N60-N30L-A WA
400	Madison	'02→'06	YB12AL-A2 WA-N	NB12AL-A2 WA	350	V 35	'77→'79	Y60-N30L-A WA-N	N60-N30L-A WA
500	Spidermax GT	'04→'11	YB14L-A2 WA-N	NB14L-A2 WA	350	V 35 II	'80→'85	Y60-N30L-A WA-N	N60-N30L-A WA
500	Spidermax RS	'08→'11	YB14L-A2 WA-N	NB14L-A2 WA	350	V 35 III	'85→'87	Y60-N30L-A WA-N	N60-N30L-A WA
MBK					500	V 50	'77→'79	Y60-N30L-A WA-N	N60-N30L-A WA
50	Booster All Model	'90→'10	YB4L-B WA-N	NB4L-B WA	500	V 50 III	'80→'84	Y60-N30L-A WA-N	N60-N30L-A WA
50	Booster Naked	'05→'10	YB4L-B WA-N	NB4L-B WA	500	V 50PA	'92→'01	Y60-N30L-A WA-N	N60-N30L-A WA
50	Booster Next Gen.	'95→'06	YB4L-B WA-N	NB4L-B WA	650	V 65 Custom	'82→'86	Y60-N30L-A WA-N	N60-N30L-A WA
50	Booster Road	'94→'95	YB4L-B WA-N	NB4L-B WA	650	V 65 Florida	'86→'92	Y60-N30L-A WA-N	N60-N30L-A WA
50	Booster Rocket	'97→'98	YB4L-B WA-N	NB4L-B WA	750	Nevada	'92→'03	Y60-N30L-A WA-N	N60-N30L-A WA
50	Booster Spirit	'96→'09	YB4L-B WA-N	NB4L-B WA	750	Nevada Club	'98→'06	Y60-N30L-A WA-N	N60-N30L-A WA
50	Booster Spirit	'99→'06	YB4L-B WA-N	NB4L-B WA	750	V7 Cafè Classic	'09→'12	YTX14-BS-N	NTX14-BS
50	Booster Track	'96→'98	YB4L-B WA-N	NB4L-B WA	750	V7 Classic	'08→'12	YTX14-BS-N	NTX14-BS
50	Booster X	'07→'10	YB4L-B WA-N	NB4L-B WA	750	V7 II Racer ABS	'15→'17	YTX14-BS-N	NTX14-BS
50	Evolis	'92→'95	YB4L-B WA-N	NB4L-B WA	750	V7 II Special ABS	'15→'17	YTX14-BS-N	NTX14-BS
50	Evolis	'97	YB4L-B WA-N	NB4L-B WA	750	V7 II Stone ABS	'15→'17	YTX14-BS-N	NTX14-BS
50	Fizz	'93→'97	YB4L-B WA-N	NB4L-B WA	750	V7 II Stor. ABS	'16→'17	YTX14-BS-N	NTX14-BS
50	Flipper	'98→'10	YB4L-B WA-N	NB4L-B WA	750	V7 III Ann. ABS	'17→'18	YTX14-BS-N	NTX14-BS
50	Forte	'94→'95	YB4L-B WA-N	NB4L-B WA	750	V7 III Carbon	'18→'19	YTX14-BS-N	NTX14-BS
50	Mach G	'02→'04	YB4L-B WA-N	NB4L-B WA	750	V7 III Limited	'18	YTX14-BS-N	NTX14-BS
50	Nitro	'97→'10	YB4L-B WA-N	NB4L-B WA	750	V7 III Milano	'18→'19	YTX14-BS-N	NTX14-BS
50	Nitro Naked	'06→'10	YB4L-B WA-N	NB4L-B WA	750	V7 III Racer ABS	'17→'19	YTX14-BS-N	NTX14-BS
50	Ovetto (4T)	'09→'10	YB4L-B WA-N	NB4L-B WA	750	V7 III Rough	'18→'20	YTX14-BS-N	NTX14-BS
50	Ovetto R	'98→'10	YB4L-B WA-N	NB4L-B WA	750	V7 III Special ABS	'17→'20	YTX14-BS-N	NTX14-BS
50	Power Rocket	'06	YB4L-B WA-N	NB4L-B WA	750	V7 III Stone ABS	'17→'20	YTX14-BS-N	NTX14-BS
50	Sorriso	'91→'95	YB4L-B WA-N	NB4L-B WA	750	V7 Racer	'10→'14	YTX14-BS-N	NTX14-BS
50	Sorriso	'95→'96	YB4L-B WA-N	NB4L-B WA	750	V7 Racer	'10→'14	YTX14-BS-N	NTX14-BS
50	Stunt	'00→'06	YB4L-B WA-N	NB4L-B WA	750	V7 III Racer 10th Anniversary ABS	'20	YTX14-BS-N	NTX14-BS
50	Stunt Naked	'05→'10	YB4L-B WA-N	NB4L-B WA	750	V7 Special	'12→'14	YTX14-BS-N	NTX14-BS
50	Target	'91→'95	YB4L-B WA-N	NB4L-B WA	750	V7 Stone	'12→'14	YTX14-BS-N	NTX14-BS
80	Evolis	'97	YB4L-B WA-N	NB4L-B WA					

BATTERIE / BATTERY

CC	Modello Model	Anno Years	Vecchio Codice Old Code	Nuovo Codice New Code
750	V75	'92→'96	Y60-N30L-A WA-N	N60-N30L-A WA
850	Le Mans	'78→'78	Y60-N30L-A WA-N	N60-N30L-A WA
850	Le Mans II	'79→'80	Y60-N30L-A WA-N	N60-N30L-A WA
850	Le Mans III	'81→'84	Y60-N30L-A WA-N	N60-N30L-A WA
850	T3 California	'79	Y60-N30L-A WA-N	N60-N30L-A WA
850	T4 California	'80→'82	Y60-N30L-A WA-N	N60-N30L-A WA
850	T5	'95→'01	Y60-N30L-A WA-N	N60-N30L-A WA
850	T5 California	'83→'88	Y60-N30L-A WA-N	N60-N30L-A WA
850	V85 TT	'19→'20	YTX14-BS-N	NTX14-BS
850	V85 TT Trav. ABS	'20	YTX14-BS-N	NTX14-BS
850	V9 Bobber	'16→'20	YTX14-BS-N	NTX14-BS
850	V9 Bobber Sport	'19	YTX14-BS-N	NTX14-BS
850	V9 Roamer	'16→'19	YTX14-BS-N	NTX14-BS
1000	California II	'83→'86	Y60-N30L-A WA-N	N60-N30L-A WA
1000	California III	'87→'93	Y60-N30L-A WA-N	N60-N30L-A WA
1000	California III	90→'93	Y60-N30L-A WA-N	N60-N30L-A WA
1000	GT	'87→'91	Y60-N30L-A WA-N	N60-N30L-A WA
1000	Le Mans	'83→'94	Y60-N30L-A WA-N	N60-N30L-A WA
1000	S	'89→'94	Y60-N30L-A WA-N	N60-N30L-A WA
1000	SP	'79→'83	Y60-N30L-A WA-N	N60-N30L-A WA
1000	SP II	'84→'88	Y60-N30L-A WA-N	N60-N30L-A WA
1000	SP III	'89→'94	Y60-N30L-A WA-N	N60-N30L-A WA
1000	Strada	'93→'94	Y60-N30L-A WA-N	N60-N30L-A WA
1100	California	'94→'97	Y60-N30L-A WA-N	N60-N30L-A WA
1100	California Alu.	'03→'05	Y60-N30L-A WA-N	N60-N30L-A WA
1100	California EV	'97→'01	Y60-N30L-A WA-N	N60-N30L-A WA
1100	California Jackal	'99→'02	Y60-N30L-A WA-N	N60-N30L-A WA
1100	California Metal	'02→'03	Y60-N30L-A WA-N	N60-N30L-A WA
1100	California Special	'98→'00	Y60-N30L-A WA-N	N60-N30L-A WA
1100	California Special Sport	'01→'02	Y60-N30L-A WA-N	N60-N30L-A WA
1100	California Stone	'01→'05	Y60-N30L-A WA-N	N60-N30L-A WA
1100	California Tit.	'03→'05	Y60-N30L-A WA-N	N60-N30L-A WA
1100	Le Mans	'01→'04	Y60-N30L-A WA-N	N60-N30L-A WA
1100	Sport	'94→'96	Y60-N30L-A WA-N	N60-N30L-A WA

MOTO MORINI

350	Dart	'87	YB14L-A2 WA-N	NB14L-A2 WA
-----	------	-----	---------------	--------------------

MV AGUSTA

675	Brutale	'13→'17	YTX10S-BS-N	NTZ10S-BS
675	F3	'11→'20	YTX10S-BS-N	NTZ10S-BS
675	F3 Oro	'12→'13	YTX10S-BS-N	NTZ10S-BS
675	F3 RC	'15→'19	YTX10S-BS-N	NTZ10S-BS
750	Brutale	'01→'02	YTX10S-BS-N	NTZ10S-BS
750	Brutale Oro	'03→'05	YTX10S-BS-N	NTZ10S-BS
750	Brutale S	'01→'05	YTX10S-BS-N	NTZ10S-BS
750	F4	'99→'05	YTX10S-BS-N	NTZ10S-BS
750	F4 Oro	'99→'01	YTX10S-BS-N	NTZ10S-BS
750	F4 S	'99→'05	YTX10S-BS-N	NTZ10S-BS
750	F4 Senna	'02→'04	YTX10S-BS-N	NTZ10S-BS
750	F4 SPR	'03→'05	YTX10S-BS-N	NTZ10S-BS
800	Brutale	'13→'18	YTX10S-BS-N	NTZ10S-BS
800	Brutale RC	'18→'19	YTX10S-BS-N	NTZ10S-BS
800	Brutale RR	'15→'16	YTX10S-BS-N	NTZ10S-BS
800	Brutale RR	'18→'20	YTX10S-BS-N	NTZ10S-BS
800	Brutale Rr Pirelli	'18→'19	YTX10S-BS-N	NTZ10S-BS
800	Dragster	'14→'16	YTX10S-BS-N	NTZ10S-BS
800	Dragster RC	'17→'20	YTX10S-BS-N	NTZ10S-BS
800	Dragster Rosso	'20	YTX10S-BS-N	NTZ10S-BS
800	Dragster RR	'15→'20	YTX10S-BS-N	NTZ10S-BS

CC	Modello Model	Anno Years	Vecchio Codice Old Code	Nuovo Codice New Code
800	Dragster RR LH44	'15→'16	YTX10S-BS-N	NTZ10S-BS
800	F3	'13→'20	YTX10S-BS-N	NTZ10S-BS
800	F3 Ago	'14→'15	YTX10S-BS-N	NTZ10S-BS
800	F3 Oro	'12→'13	YTX10S-BS-N	NTZ10S-BS
800	F3 RC	'15→'20	YTX10S-BS-N	NTZ10S-BS
800	Rivale	'13→'18	YTX10S-BS-N	NTZ10S-BS
800	Stradale	'15	YTX10S-BS-N	NTZ10S-BS
800	Turismo Veloce	'15→'19	YTX12S-BS-N	NTZ12S-BS
800	Tur. Veloce Lusso	'15→'20	YTX12S-BS-N	NTZ12S-BS
800	Tur. Veloce RC	'17→'20	YTX12S-BS-N	NTZ12S-BS
800	Tur. Veloce Rosso	'20	YTX12S-BS-N	NTZ12S-BS
910	Brutale R	'05→'08	YTX10S-BS-N	NTZ10S-BS
910	Brutale S	'05→'08	YTX10S-BS-N	NTZ10S-BS
920	Brutale	'10→'12	YTX10S-BS-N	NTZ10S-BS
989	Brutale R	'07→'11	YTX10S-BS-N	NTZ10S-BS
990	Brutale R	'09→'12	YTX10S-BS-N	NTZ10S-BS
1000	F4	'04→'06	YTX10S-BS-N	NTZ10S-BS
1000	F4	'13→'16	YTX10S-BS-N	NTZ10S-BS
1000	F4 312R	'07→'08	YTX10S-BS-N	NTZ10S-BS
1000	F4 R	'06→'07	YTX10S-BS-N	NTZ10S-BS
1000	F4 R	'12→'16	YTX10S-BS-N	NTZ10S-BS
1000	F4 RR	'10→'16	YTX10S-BS-N	NTZ10S-BS
1000	F4 RR C. Corta	'12	YTX10S-BS-N	NTZ10S-BS
1078	Brutale RR	'08→'09	YTX10S-BS-N	NTZ10S-BS
1078	F4 312RR	'07→'09	YTX10S-BS-N	NTZ10S-BS
1078	F4 C. Castiglioni	'07→'07	YTX10S-BS-N	NTZ10S-BS
1090	Brutale	'13→'15	YTX10S-BS-N	NTZ10S-BS
1090	Brutale Corsa	'13→'15	YTX10S-BS-N	NTZ10S-BS
1090	Brutale R	'12→'15	YTX10S-BS-N	NTZ10S-BS
1090	Brutale RR	'10→'16	YTX10S-BS-N	NTZ10S-BS

MZ-MUZ

125	Saxon	'93→'97	YB5L-B WA-N	NB5L-B WA
-----	-------	---------	-------------	------------------

NORTON

961	Commando Cafe Racer	'10→'15	YTX14S-BS-N	NTZ14S-BS
961	Commando SE Special Edition	'10→'11	YTX14S-BS-N	NTZ14S-BS
961	Commando SF Sport Factory	'13→'14	YTX14S-BS-N	NTZ14S-BS
961	Commando Sport	'10→'15	YTX14S-BS-N	NTZ14S-BS

PEUGEOT

50	Blaster Iceblade	'10→'12	YB4L-B WA-N	NB4L-B WA
50	Blaster RS 12	'10→'11	YB4L-B WA-N	NB4L-B WA
50	Buxy	'94→'97	YB4L-B WA-N	NB4L-B WA
50	Buxy RS	'94→'97	YB4L-B WA-N	NB4L-B WA
50	Django Allure 2T	'14→'17	YTX7A-BS-N	NTX7A-BS
50	Django Allure 4T	'14→'17	YTX7A-BS-N	NTX7A-BS
50	Django Evasion 2T	'14→'19	YTX7A-BS-N	NTX7A-BS
50	Django Evasion 4T	'14→'17	YTX7A-BS-N	NTX7A-BS
50	Django Heritage 2T	'14→'17	YTX7A-BS-N	NTX7A-BS
50	Django Heritage 4T	'14→'17	YTX7A-BS-N	NTX7A-BS
50	Django S 2T	'14→'17	YTX7A-BS-N	NTX7A-BS
50	Django S 4T	'14→'17	YTX7A-BS-N	NTX7A-BS
50	Django Sport 2T	'14→'19	YTX7A-BS-N	NTX7A-BS
50	Django Sport 4T	'14→'17	YTX7A-BS-N	NTX7A-BS
50	Elyseo	'98→'03	YB4L-B WA-N	NB4L-B WA
50	Fox	'94→'98	YB4L-B WA-N	NB4L-B WA
50	H2I Jet	'11→'12	YB4L-B WA-N	NB4L-B WA

BATTERIE / BATTERY

CC	Modello Model	Anno Years	Vecchio Codice Old Code	Nuovo Codice New Code	CC	Modello Model	Anno Years	Vecchio Codice Old Code	Nuovo Codice New Code
50	Jet C Tech	'11→'12	YB4L-B WA-N	NB4L-B WA	50	Speedfight 4 Classic 4T	'15	YB4L-B WA-N	NB4L-B WA
50	Jet C-Tech Dark	'10→'13	YB4L-B WA-N	NB4L-B WA	50	Speedfight 4 Classic 4T	'15→'19	YB4L-B WA-N	NB4L-B WA
50	Jet C-Tech Ice Blade	'11→'13	YB4L-B WA-N	NB4L-B WA	50	Speedfight 4 Darkside 2T	'15	YB4L-B WA-N	NB4L-B WA
50	Jet Force	'03→'10	YB4L-B WA-N	NB4L-B WA	50	Speedfight 4 Darkside 2T	'15→'18	YB4L-B WA-N	NB4L-B WA
50	Jet Force/Jet-C	'03→'10	YB4L-B WA-N	NB4L-B WA	50	Speedfight 4 Darkside 4T	'15	YB4L-B WA-N	NB4L-B WA
50	Kisbee 2T	'10→'15	YTX5L-BS-N	NTX5L-BS	50	Speedfight 4 Darkside 4T	'15→'18	YB4L-B WA-N	NB4L-B WA
50	Kisbee 4T	'10→'19	YTX5L-BS-N	NTX5L-BS	50	Speedfight 4 Darkside 4T	'15→'18	YB4L-B WA-N	NB4L-B WA
50	Kisbee RS 2T	'10→'15	YTX5L-BS-N	NTX5L-BS	50	Speedfight 4 Iceblade 2T	'15→'16	YB4L-B WA-N	NB4L-B WA
50	Kisbee RS 4T	'10→'19	YTX5L-BS-N	NTX5L-BS	50	Speedfight 4 Iceblade 2T	'15→'18	YB4L-B WA-N	NB4L-B WA
50	L Fox	'94→'98	YB4L-B WA-N	NB4L-B WA	50	Speedfight 4 Iceblade 4T	'15	YB4L-B WA-N	NB4L-B WA
50	Looxor	'01→'06	YB4L-B WA-N	NB4L-B WA	50	Speedfight 4 Iceblade 4T	'15→'18	YB4L-B WA-N	NB4L-B WA
50	Ludix 2 Biposto	'07→'09	YB4L-B WA-N	NB4L-B WA	50	Speedfight 4 Iceblade 4T	'15→'18	YB4L-B WA-N	NB4L-B WA
50	Ludix 2 One Bip.	'10→'12	YB4L-B WA-N	NB4L-B WA	50	Speedf. 4 Pure 2T	'15	YB4L-B WA-N	NB4L-B WA
50	Ludix 2 One Mon.	'10→'11	YB4L-B WA-N	NB4L-B WA	50	Speedf. 4 Pure 2T	'15→'18	YB4L-B WA-N	NB4L-B WA
50	Ludix 2 Trend	'07→'12	YB4L-B WA-N	NB4L-B WA	50	Speedf. 4 Pure 4T	'15	YB4L-B WA-N	NB4L-B WA
50	Ludix Acid	'06	YB4L-B WA-N	NB4L-B WA	50	Speedf. 4 Pure 4T	'15→'18	YB4L-B WA-N	NB4L-B WA
50	Ludix Blaster	'05→'09	YB4L-B WA-N	NB4L-B WA	50	Speedf. 4 R-Cup	'18→'19	YB4L-B WA-N	NB4L-B WA
50	Ludix Bullet	'04	YB4L-B WA-N	NB4L-B WA	50	Squab	'95→'01	YB4L-B WA-N	NB4L-B WA
50	Ludix Classic	'04→'05	YB4L-B WA-N	NB4L-B WA	50	SV GEO	'91→'93	YB4L-B WA-N	NB4L-B WA
50	Ludix Elegance	'04→'09	YB4L-B WA-N	NB4L-B WA	50	SV J GEO	'91→'95	YB4L-B WA-N	NB4L-B WA
50	Ludix PRO	'11→'13	YB4L-B WA-N	NB4L-B WA	50	TKR	'09→'12	YB4L-B WA-N	NB4L-B WA
50	Ludix Red Zone	'06→'06	YB4L-B WA-N	NB4L-B WA	50	TKR WRC	'99→'08	YB4L-B WA-N	NB4L-B WA
50	Ludix Snake	'04→'09	YB4L-B WA-N	NB4L-B WA	50	Trekker	'98→'00	YB4L-B WA-N	NB4L-B WA
50	Ludix trend	'04→'07	YB4L-B WA-N	NB4L-B WA	50	Tweet	'10→'13	YB4L-B WA-N	NB4L-B WA
50	Ludix Urban Track	'06→'07	YB4L-B WA-N	NB4L-B WA	50	Tweet RS	'10→'13	YB4L-B WA-N	NB4L-B WA
50	Metal-X	'04→'06	YB4L-B WA-N	NB4L-B WA	50	V-Clic	'08→'13	YB4L-B WA-N	NB4L-B WA
50	New Tweet Evo RS	'14→'15	YB4L-B WA-N	NB4L-B WA	50	Vivacity	'02→'07	YB4L-B WA-N	NB4L-B WA
50	New Vivacity	'08→'09	YB4L-B WA-N	NB4L-B WA	50	Vivacity 2	'08→'11	YB4L-B WA-N	NB4L-B WA
50	New Vivacity	'08→'09	YB4L-B WA-N	NB4L-B WA	50	Vivacity Sixties 4T	'10→'11	YB4L-B WA-N	NB4L-B WA
50	New Vivacity 2T	'10→'14	YB4L-B WA-N	NB4L-B WA	50	Vogue	'08→'09	YB4L-B WA-N	NB4L-B WA
50	New Vivacity 4T	'10→'14	YB4L-B WA-N	NB4L-B WA	50	XP6 Enduro	'01→'05	YB4L-B WA-N	NB4L-B WA
50	New Vivacity Sixties	'10	YB4L-B WA-N	NB4L-B WA	50	XP6 SM	'01→'03	YB4L-B WA-N	NB4L-B WA
50	New Vivacity Sixties 4T	'11→'13	YB4L-B WA-N	NB4L-B WA	50	XP6 SM Top Road	'04→'12	YB4L-B WA-N	NB4L-B WA
50	NK 7 Naked	'09→'13	YTX5L-BS-N	NTX5L-BS	50	XP6 Track	'06→'12	YB4L-B WA-N	NB4L-B WA
50	Speedake	'95→'01	YB4L-B WA-N	NB4L-B WA	50	XPS SM	'09	YB4L-B WA-N	NB4L-B WA
50	Speedake	'95→'01	YB4L-B WA-N	NB4L-B WA	50	XPS SM Street	'03→'09	YB4L-B WA-N	NB4L-B WA
50	Speedake	'95→'01	YB4L-B WA-N	NB4L-B WA	50	XPS SM Top Road	'03→'12	YB4L-B WA-N	NB4L-B WA
50	Speedake	'95→'01	YB4L-B WA-N	NB4L-B WA	50	XPS Track	'03→'12	YB4L-B WA-N	NB4L-B WA
50	Speedfight	'97→'08	YB4L-B WA-N	NB4L-B WA	50	XR6	'01→'07	YB4L-B WA-N	NB4L-B WA
50	Speedfight 3 2T	'09→'15	YB4L-B WA-N	NB4L-B WA	50	XR7 Full Fairing	'08→'13	YB4L-B WA-N	NB4L-B WA
50	Speedfight 3 2T	'09→'15	YB4L-B WA-N	NB4L-B WA	50	Zenith	'96→'99	YB4L-B WA-N	NB4L-B WA
50	Speedfight 3 4T	'09→'14	YB4L-B WA-N	NB4L-B WA	50	Zenith LS	'96→'99	YB4L-B WA-N	NB4L-B WA
50	Speedfight 3 Darkside 2T	'13→'15	YB4L-B WA-N	NB4L-B WA	50	Zenith M/N	'96→'00	YB4L-B WA-N	NB4L-B WA
50	Speedfight 3 Darkside 2T	'13→'15	YB4L-B WA-N	NB4L-B WA	80	SV GEO	'91→'93	YB5L-B WA-N	NB5L-B WA
50	Speedfight 3 Fur	'13	YB4L-B WA-N	NB4L-B WA	100	ELYSEO	'98→'03	YTX5L-BS-N	NTX5L-BS
50	Speedfight 3 Iceblade 2T	'13→'15	YB4L-B WA-N	NB4L-B WA	100	Kisbee	'12→'14	YTX7A-BS-N	NTX7A-BS
50	Speedfight 3 Iceblade 2T	'13→'15	YB4L-B WA-N	NB4L-B WA	100	Looxor	'01→'04	YTX5L-BS-N	NTX5L-BS
50	Speedfight 3 Iceblade 4T	'15	YB4L-B WA-N	NB4L-B WA	100	Speedfight	'97→'07	YTX5L-BS-N	NTX5L-BS
50	Speedfight 3 RS	'09→'12	YB4L-B WA-N	NB4L-B WA	100	Streetzone	'14→'15	YTX5L-BS-N	NTX5L-BS
50	Speedfight 3 RS	'10→'12	YB4L-B WA-N	NB4L-B WA	100	SV L	'98→'99	YB5L-B WA-N	NB5L-B WA
50	Speedfight 4 20 ANS Ed.	'18	YB4L-B WA-N	NB4L-B WA	100	Trekker	'98→'00	YTX5L-BS-N	NTX5L-BS
50	Speedfight 4 Classic 2T	'15	YB4L-B WA-N	NB4L-B WA	100	Vivacity	'02→'07	YTX5L-BS-N	NTX5L-BS
50	Speedfight 4 Classic 2T	'15→'19	YB4L-B WA-N	NB4L-B WA	110	VOX	'12→'13	YTX5L-BS-N	NTX5L-BS
					125	City Star	'11→'15	YTX9-BS-N	NTX9-BS

BATTERIE / BATTERY

CC	Modello Model	Anno Years	Vecchio Codice Old Code	Nuovo Codice New Code
125	City Star Active I	'13	YB12AL-A2 WA-N	NB12AL-A2 WA
125	City Star Blue Line	'15	YTX9-BS-N	NTX9-BS
125	City Star I	'13	YB12AL-A2 WA-N	NB12AL-A2 WA
125	Django Allure	'14→'19	YTX7A-BS-N	NTX7A-BS
125	Django Allure SBC	'14→'19	YTX7A-BS-N	NTX7A-BS
125	Django Evasion	'14→'19	YTX7A-BS-N	NTX7A-BS
125	Django Ev. SBC	'14→'19	YTX7A-BS-N	NTX7A-BS
125	Django Heritage	'14→'19	YTX7A-BS-N	NTX7A-BS
125	Django Heritage SBC	'14→'19	YTX7A-BS-N	NTX7A-BS
125	Django S	'14→'19	YTX7A-BS-N	NTX7A-BS
125	Django Sport	'14→'19	YTX7A-BS-N	NTX7A-BS
125	Django Sport SBC	'14→'19	YTX7A-BS-N	NTX7A-BS
125	GEO RS	'07→'12	YB12AL-A2 WA-N	NB12AL-A2 WA
125	Geopolis ABS	'07→'13	YB12AL-A2 WA-N	NB12AL-A2 WA
125	Geopolis Executive	'07→'13	YB12AL-A2 WA-N	NB12AL-A2 WA
125	Geopolis Premium	'07→'12	YB12AL-A2 WA-N	NB12AL-A2 WA
125	Geopolis Urban ABS	'07→'12	YB12AL-A2 WA-N	NB12AL-A2 WA
125	Jet Force	'03→'11	YB12AL-A2 WA-N	NB12AL-A2 WA
125	Looxor	'03→'06	YB12AL-A2 WA-N	NB12AL-A2 WA
125	Ludix Ambition	'04→'04	YB12AL-A2 WA-N	NB12AL-A2 WA
125	LXR	'10→'15	YTX9-BS-N	NTX9-BS
125	New Tweet EVO	'14→'19	YTX7A-BS-N	NTX7A-BS
125	New Tw. EVO RS	'14→'15	YTX7A-BS-N	NTX7A-BS
125	New Tw. EVO RS	'14→'19	YTX7A-BS-N	NTX7A-BS
125	Satelis	'13	YB12AL-A2 WA-N	NB12AL-A2 WA
125	Satelis Avenue	'08→'09	YB12AL-A2 WA-N	NB12AL-A2 WA
125	Satelis Blacksat	'10→'12	YB12AL-A2 WA-N	NB12AL-A2 WA
125	Satelis City 4V	'06→'09	YB12AL-A2 WA-N	NB12AL-A2 WA
125	Satelis Compr.	'06→'12	YB12AL-A2 WA-N	NB12AL-A2 WA
125	Satelis Executive 4V	'06→'09	YB12AL-A2 WA-N	NB12AL-A2 WA
125	Satelis Premium 4V	'06→'09	YB12AL-A2 WA-N	NB12AL-A2 WA
125	Satelis RS	'07→'12	YB12AL-A2 WA-N	NB12AL-A2 WA
125	Satelis RS	'13	YB12AL-A2 WA-N	NB12AL-A2 WA
125	Satelis Urban ABS	'07→'12	YB12AL-A2 WA-N	NB12AL-A2 WA
125	Satelis Whitesat	'10→'12	YB12AL-A2 WA-N	NB12AL-A2 WA
125	Speedfight	'14→'15	YTX7A-BS-N	NTX7A-BS
125	Speedf. Darkside	'14→'15	YTX7A-BS-N	NTX7A-BS
125	Speedf. Iceblade	'14→'15	YTX7A-BS-N	NTX7A-BS
125	Speedf. Team	'14→'15	YTX7A-BS-N	NTX7A-BS
125	Sum-UP	'08→'11	YTX7A-BS-N	NTX7A-BS
125	SV GEO	'91→'93	YB5L-B WA-N	NB5L-B WA
125	Tweet	'10→'13	YTX7A-BS-N	NTX7A-BS
125	Tweet RS	'10→'13	YTX7A-BS-N	NTX7A-BS
125	Vivacity	'10→'15	YTX7A-BS-N	NTX7A-BS
125	Vivacity Sixties	'11→'12	YTX7A-BS-N	NTX7A-BS
150	Django Allure	'14→'17	YTX7A-BS-N	NTX7A-BS
150	Django Evasion	'14→'19	YTX7A-BS-N	NTX7A-BS
150	Django Heritage	'14→'19	YTX7A-BS-N	NTX7A-BS
150	Django S	'14→'19	YTX7A-BS-N	NTX7A-BS
150	Django Sport	'14→'19	YTX7A-BS-N	NTX7A-BS
150	Tweet	'10→'12	YTX7A-BS-N	NTX7A-BS
150	Tweet EVO RS	'14→'19	YTX7A-BS-N	NTX7A-BS
150	Tweet RS	'10→'12	YTX7A-BS-N	NTX7A-BS
200	City Star I	'12→'15	YTX9-BS-N	NTX9-BS
200	LXR I	'10→'11	YTX9-BS-N	NTX9-BS
250	GEO	'07→'11	YB12AL-A2 WA-N	NB12AL-A2 WA
250	Geopolis Exec.	'07→'12	YB12AL-A2 WA-N	NB12AL-A2 WA
250	Geopolis Premium	'07→'11	YB12AL-A2 WA-N	NB12AL-A2 WA
250	Geopolis Urb. ABS	'07→'11	YB12AL-A2 WA-N	NB12AL-A2 WA
250	Satelis Premium	'07→'12	YB12AL-A2 WA-N	NB12AL-A2 WA
250	Satelis RS	'07→'12	YB12AL-A2 WA-N	NB12AL-A2 WA
250	Satelis Urban ABS	'07→'12	YB12AL-A2 WA-N	NB12AL-A2 WA

CC	Modello Model	Anno Years	Vecchio Codice Old Code	Nuovo Codice New Code
250	Satelis Urban ABS	'07→'12	YB12AL-A2 WA-N	NB12AL-A2 WA
250	SV	'01→'02	YTX12-BS-N	NTX12-BS
300	GEO RS	'10→'12	YB12AL-A2 WA-N	NB12AL-A2 WA
300	Geopolis	'10→'13	YB12AL-A2 WA-N	NB12AL-A2 WA
300	Geostyle	'10→'12	YB12AL-A2 WA-N	NB12AL-A2 WA
300	Satelis	'13→'13	YTX12-BS-N	NTX12-BS
300	Satelis 2	'14→'15	YTX12-BS-N	NTX12-BS
400	GEO RS	'08→'12	YB14L-A2 WA-N	NB14L-A2 WA
400	Geopolis	'07→'13	YB14L-A2 WA-N	NB14L-A2 WA
400	Geopolis GT	'14	YB14L-A2 WA-N	NB14L-A2 WA
400	Geopolis Prem.	'07→'12	YB14L-A2 WA-N	NB14L-A2 WA
400	Geopolis Urb. ABS	'07→'12	YB14L-A2 WA-N	NB14L-A2 WA
400	Metropolis	'13→'17	YTX14-BS-N	NTX14-BS
400	Metropolis Active	'17→'18	YTX14-BS-N	NTX14-BS
400	Metropolis Allure	'17→'19	YTX14-BS-N	NTX14-BS
400	Metropolis GT	'15→'16	YTX14-BS-N	NTX14-BS
400	Metropolis RS	'14→'17	YTX14-BS-N	NTX14-BS
400	Metropolis RS ABS	'17→'20	YTX14-BS-N	NTX14-BS
400	Metropolis RX-R	'17→'19	YTX14-BS-N	NTX14-BS
400	Metropolis Sport	'15→'16	YTX14-BS-N	NTX14-BS
400	Satelis Premium	'08→'11	YTX12-BS-N	NTX12-BS
400	Satelis RS	'08→'12	YTX12-BS-N	NTX12-BS
400	Satelis Urban	'08→'12	YTX12-BS-N	NTX12-BS
500	Geopolis	'08→'13	YB14L-A2 WA-N	NB14L-A2 WA
500	Satelis	'07→'13	YTX12-BS-N	NTX12-BS
500	Satelis RS	'08→'12	YTX12-BS-N	NTX12-BS

PGO

50	Big Max	'94→'96	YB4L-B WA-N	NB4L-B WA
125	G-Max	'06→'12	YTX7A-BS-N	NTX7A-BS
125	T-Rex	'99→'12	YTX7A-BS-N	NTX7A-BS

PIAGGIO

0	Liberty Elettrico PPT AUT	'11	YTX7L-BS-N	NTX7L-BS
0	Vespa Elettrica	'18→'19	YTX5L-BS-N	NTX5L-BS
0	Vespa Elettrica	'19	YTX5L-BS-N	NTX5L-BS
0	Vespa Elettrica Motociclo	'19	YTX5L-BS-N	NTX5L-BS
50	APE	'09→'17	YB9-B WA-N	NB9-B WA
50	APE FL3 Europa	'96→'99	YB9-B WA-N	NB9-B WA
50	APE MIX 2T	'98→'08	YB9-B WA-N	NB9-B WA
50	APE RST MIX	'99→'03	YB9-B WA-N	NB9-B WA
50	Diesis	'01→'01	YB4L-B WA-N	NB4L-B WA
50	FLY 2T	'05→'07	YB9-B WA-N	NB9-B WA
50	FLY 2T	'10	YB4L-B WA-N	NB4L-B WA
50	FLY 4T	'05→'07	YB9-B WA-N	NB9-B WA
50	FLY 4T	'06→'07	YB9-B WA-N	NB9-B WA
50	FLY 4T	'08→'11	YB9-B WA-N	NB9-B WA
50	FLY 4T 2V	'12→'17	YTX7L-BS-N	NTX7L-BS
50	FLY 4T 2V	'13→'15	YTX7L-BS-N	NTX7L-BS
50	FLY 4T 4V	'12→'13	YTX7L-BS-N	NTX7L-BS
50	Free	'92→'94	YB4L-B WA-N	NB4L-B WA
50	Free FL	'95→'02	YB4L-B WA-N	NB4L-B WA
50	Liberty	'97→'05	YB4L-B WA-N	NB4L-B WA
50	Liberty 2T	'06→'06	YB4L-B WA-N	NB4L-B WA
50	Liberty 2T	'06→'06	YB9-B WA-N	NB9-B WA
50	Liberty 2T	'07→'08	YB9-B WA-N	NB9-B WA
50	Liberty 2T RST	'04	YB4L-B WA-N	NB4L-B WA
50	Liberty 2T Sport	'06	YB4L-B WA-N	NB4L-B WA
50	Liberty 2T Sport	'06	YB9-B WA-N	NB9-B WA

BATTERIE / BATTERY

CC	Modello Model	Anno Years	Vecchio Codice Old Code	Nuovo Codice New Code	CC	Modello Model	Anno Years	Vecchio Codice Old Code	Nuovo Codice New Code
50	Liberty 2T Sport	'07→'08	YB9-B WA-N	NB9-B WA	50	Typhoon 2T	'11	YB9-B WA-N	NB9-B WA
50	Liberty 4T	'00→'02	YB9-B WA-N	NB9-B WA		CH Euro 3			
50	Liberty 4T	'05→'08	YB9-B WA-N	NB9-B WA	50	Typhoon 2T	'18→'20	YTX5L-BS-N	NTX5L-BS
50	Liberty 4T Deliver Single	'10→'14	YB9-B WA-N	NB9-B WA		Euro 4			
50	Liberty 4T Delivery TNT	'09	YB9-B WA-N	NB9-B WA	50	Velofax	'96→'99	YB4L-B WA-N	NB4L-B WA
50	Liberty 4T Iget Corp. Euro 4	'18	YTX12-BS-N	NTX12-BS	50	Vespa ET2	'97→'05	YB4L-B WA-N	NB4L-B WA
50	Liberty 4T PTT - Double - Nexive	'09→'17	YB9-B WA-N	NB9-B WA	50	Vespa ET2 Iniez.	'97→'00	YB5L-B WA-N	NB5L-B WA
50	Liberty 4T PTT (DEU)	'07→'12	YB9-B WA-N	NB9-B WA	50	Vespa ET4	'00→'05	YB9-B WA-N	NB9-B WA
50	Liberty 4T RST	'04	YB9-B WA-N	NB9-B WA	50	Vespa FL	'90→'90	YB5L-B WA-N	NB5L-B WA
50	Liberty 4T Sport	'06	YB9-B WA-N	NB9-B WA	50	Vespa FL2	'90→'91	YB5L-B WA-N	NB5L-B WA
50	Liberty 4T Sport	'07→'08	YB9-B WA-N	NB9-B WA		Automatica			
50	Liberty Iget 4T 3V	'16	YTX7L-BS-N	NTX7L-BS	50	Vespa FL2 HP	'91→'97	YB9-B WA-N	NB9-B WA
50	Liberty Iget 4T 3V IE	'15→'17	YTX7L-BS-N	NTX7L-BS	50	Vespa LX 2T	'05→'08	YB4L-B WA-N	NB4L-B WA
50	Liberty Iget 4T 3V IE Euro 4	'17→'19	YTX7L-BS-N	NTX7L-BS	50	Vespa LX 2T	'05→'08	YB9-B WA-N	NB9-B WA
50	Liberty MOC 2T & Elle	'09→'13	YB4L-B WA-N	NB4L-B WA	50	Vespa LX 2T	'09→'13	YB4L-B WA-N	NB4L-B WA
50	Liberty MOC 4T & Elle	'09→'16	YB9-B WA-N	NB9-B WA	50	Vespa LX 2T	'09→'13	YB9-B WA-N	NB9-B WA
50	NRG	'94→'96	YB4L-B WA-N	NB4L-B WA	50	Vespa LX 2T Tour.	'10→'13	YB4L-B WA-N	NB4L-B WA
50	NRG MC3	'01→'04	YB4L-B WA-N	NB4L-B WA	50	Vespa LX 2T Tour.	'10→'13	YB9-B WA-N	NB9-B WA
50	NRG Power DD	'05→'05	YB4L-B WA-N	NB4L-B WA	50	Vespa LX 4T	'05→'09	YB9-B WA-N	NB9-B WA
50	NRG Power DD	'06→'06	YB4L-B WA-N	NB4L-B WA	50	Vespa LX 4T-4V	'09→'13	YB9-B WA-N	NB9-B WA
50	NRG Power DD	'07→'17	YB4L-B WA-N	NB4L-B WA	50	Vespa LX 4T-4V Touring	'10→'13	YB9-B WA-N	NB9-B WA
50	NRG Power DD	'07→'17	YB9-B WA-N	NB9-B WA	50	Vespa LXV 2T	'06→'09	YB9-B WA-N	NB9-B WA
50	NRG Power DD	'07→'12	YB9-B WA-N	NB9-B WA	50	Vespa LXV 2T Navy	'08	YB9-B WA-N	NB9-B WA
	Serie Speciale				50	Vespa N	'89→'90	YB9-B WA-N	NB9-B WA
50	NRG Power DT	'06	YB4L-B WA-N	NB4L-B WA	50	Vespa PK	'82→'84	YB5L-B WA-N	NB5L-B WA
50	NRG Power DT	'07→'15	YB4L-B WA-N	NB4L-B WA	50	Vespa PK XL	'85→'88	YB9-B WA-N	NB9-B WA
50	NRG Power DT	'07→'15	YB9-B WA-N	NB9-B WA	50	Vespa Pk XI Rush	'88→'89	YB9-B WA-N	NB9-B WA
50	NRG Power DT	'07→'08	YB9-B WA-N	NB9-B WA	50	Vespa Prim. 2T	'13→'17	YB4L-B WA-N	NB4L-B WA
50	NRG Power H2O Euro 4	'18	YTX5L-BS-N	NTX5L-BS	50	Vespa Primavera 4T 2V	'14→'17	YTX7L-BS-N	NTX7L-BS
50	NRG Pow. Purejet	'04→'05	YB9-B WA-N	NB9-B WA	50	Vespa Primavera 4T 3V Euro 4	'17→'19	YTX7L-BS-N	NTX7L-BS
50	NRG Pow. Purejet	'06	YB9-B WA-N	NB9-B WA	50	Vespa Primavera 4T 3V Euro 4	'17→'18	YTX7L-BS-N	NTX7L-BS
50	NRG Pow. Purejet	'07→'09	YB9-B WA-N	NB9-B WA	50	Vespa Primavera 4T 4V	'13→'17	YTX7L-BS-N	NTX7L-BS
50	NRG Pow. Purejet	'10→'11	YB9-B WA-N	NB9-B WA	50	Vespa S 2T & College	'07→'12	YB4L-B WA-N	NB4L-B WA
50	NRG Purejet	'02→'04	YB9-B WA-N	NB9-B WA	50	Vespa S 4T-4V & College	'08→'12	YB9-B WA-N	NB9-B WA
50	NRG Purejet	'10	YB9-B WA-N	NB9-B WA	50	Vespa Sprint 2T Euro 2	'14→'17	YB4L-B WA-N	NB4L-B WA
50	NRG RST MC2	'96→'98	YB4L-B WA-N	NB4L-B WA	50	Vespa Sprint 4T 2V	'14→'17	YTX7L-BS-N	NTX7L-BS
50	NTT	'95→'96	YB4L-B WA-N	NB4L-B WA	50	Vespa Sprint 4T	'17→'19	YTX7L-BS-N	NTX7L-BS
50	Puch P1-Tre	'93→'98	YB4L-B WA-N	NB4L-B WA		3V Euro 4			
50	Quartz	'92→'96	YB4L-B WA-N	NB4L-B WA	50	Vespa Sprint 4T	'14→'17	YTX7L-BS-N	NTX7L-BS
50	Scatto	'92→'93	YB5L-B WA-N	NB5L-B WA		4V Euro 2			
50	Sfera	'91→'93	YB4L-B WA-N	NB4L-B WA	50	Vespa Sprint	'17→'19	YTX7L-BS-N	NTX7L-BS
50	Sfera Maquillage 2	'94→'94	YB4L-B WA-N	NB4L-B WA		4T-3V Euro 4			
50	sfera RST	'95→'97	YB4L-B WA-N	NB4L-B WA	50	ZIP	'92→'93	YB4L-B WA-N	NB4L-B WA
50	Typhoon	'01→'04	YB4L-B WA-N	NB4L-B WA	50	ZIP	'95→'96	YB4L-B WA-N	NB4L-B WA
50	Typhoon	'05→'08	YB4L-B WA-N	NB4L-B WA	50	ZIP	'00→'04	YB4L-B WA-N	NB4L-B WA
50	Typhoon	'05→'08	YB9-B WA-N	NB9-B WA	50	ZIP 2T	'08→'13	YB4L-B WA-N	NB4L-B WA
50	Typhoon	'09→'11	YB9-B WA-N	NB9-B WA	50	ZIP 2T	'08→'13	YB9-B WA-N	NB9-B WA
50	Typhoon 2T Euro 2	'10→'16	YB9-B WA-N	NB9-B WA	50	ZIP 4T	'00→'05	YTX9-BS-N	NTX9-BS
50	Typhoon 2T Euro 2	'10→'16	YB4L-B WA-N	NB4L-B WA	50	ZIP 4T	'06→'16	YTX9-BS-N	NTX9-BS
					50	ZIP 4T	'18→'20	YTX7L-BS-N	NTX7L-BS
						(25 KM/H)			
					50	ZIP 4T Euro 4	'18→'20	YTX7L-BS-N	NTX7L-BS
					50	ZIP Bimodale	'94→'97	YB4L-B WA-N	NB4L-B WA
					50	ZIP Fast Raider	'93→'94	YB4L-B WA-N	NB4L-B WA

BATTERIE / BATTERY

CC	Modello Model	Anno Years	Vecchio Codice Old Code	Nuovo Codice New Code	CC	Modello Model	Anno Years	Vecchio Codice Old Code	Nuovo Codice New Code
50	ZIP Fast Raider RST	'96→'97	YB4L-B WA-N	NB4L-B WA	125	MP3	'06→'08	YTX14-BS-N	NTX14-BS
50	ZIP RST	'96→'99	YB4L-B WA-N	NB4L-B WA	125	MP3 Ibrido	'09→'10	YTX14-BS-N	NTX14-BS
50	ZIP SP	'96→'00	YB4L-B WA-N	NB4L-B WA	125	MP3 IE	'08→'11	YTX14-BS-N	NTX14-BS
50	ZIP SP	'01→'04	YB4L-B WA-N	NB4L-B WA	125	MP3 IE Touring	'11→'12	YTX14-BS-N	NTX14-BS
50	ZIP SP Euro 2	'06→'13	YB4L-B WA-N	NB4L-B WA	125	MP3 Yourban ERL	'11→'13	YTX14-BS-N	NTX14-BS
80	Skr City	'99	YB5L-B WA-N	NB5L-B WA	125	Sfera	'95→'97	YB9-B WA-N	NB9-B WA
100	Diesis	'01	YTX5L-BS-N	NTX5L-BS	125	Skipper 4T	'00→'02	YB9-B WA-N	NB9-B WA
100	Fly 4T	'06→'07	YB9-B WA-N	NB9-B WA	125	Skipper LX	'98→'99	YB9-B WA-N	NB9-B WA
100	Fly 4T	'08→'14	YB9-B WA-N	NB9-B WA	125	Typhoon 4T 2V Euro 3	'10→'11	YB9-B WA-N	NB9-B WA
100	ZIP	'13→'15	YTX9-BS-N	NTX9-BS	125	Vespa 946 4T 3V ABS - 946 RED	'13→'17	YT12B-BS-N	NT12B-BS
100	ZIP	'17	YTX9-BS-N	NTX9-BS	125	Vespa 946 4T 3V ABS Armani	'15	YT12B-BS-N	NT12B-BS
100	ZIP 4T	'06→'10	YTX9-BS-N	NTX9-BS	125	Vespa ET4	'96→'98	YB9-B WA-N	NB9-B WA
125	Beverly	'01→'03	YB9-B WA-N	NB9-B WA	125	Vespa ET4	'99→'02	YB9-B WA-N	NB9-B WA
125	Beverly Euro 3	'07→'08	YTX12-BS-N	NTX12-BS	125	Vespa ET4	'99→'02	YTX9-BS-N	NTX9-BS
125	Bev. Euro 3 Sport	'07→'08	YTX12-BS-N	NTX12-BS	125	Vespa FL	'89→'90	YB9-B WA-N	NB9-B WA
125	Beverly RST	'04→'05	YB9-B WA-N	NB9-B WA	125	Vespa Granturis.	'06→'07	YB9-B WA-N	NB9-B WA
125	Beverly RST	'05→'07	YB9-B WA-N	NB9-B WA	125	Vespa Granturis. Euro 3	'06→'07	YTX12-BS-N	NTX12-BS
125	Beverly RST 4T 4V IE Euro 3	'10→'15	YTX12-BS-N	NTX12-BS	125	Vespa GTS 4T IE Super	'09→'16	YTX12-BS-N	NTX12-BS
125	Beverly Tourer Euro 3	'07→'10	YTX12-BS-N	NTX12-BS	125	Vespa GTS 4T IE Super	'09→'16	YTX14-BS-N	NTX14-BS
125	Carnaby	'07→'10	YTX12-BS-N	NTX12-BS	125	Vespa GTS Euro 3	'07→'12	YTX12-BS-N	NTX12-BS
125	Cosa 2	'91→'97	YB9-B WA-N	NB9-B WA	125	Vespa GTS IE ABS Euro 4	'16→'18	YTX7L-BS-N	NTX7L-BS
125	Cosa CL-CLX	'88→'91	YB9-B WA-N	NB9-B WA	125	Vespa GTS IE ABS Euro 4	'19	YTX7L-BS-N	NTX7L-BS
125	Fly	'05→'07	YB9-B WA-N	NB9-B WA	125	Vespa GTS IE ABS Euro 4 4T Super	'18→'19	YTX7L-BS-N	NTX7L-BS
125	Fly 4T 3V IE Euro 3	'12→'13	YT12B-BS-N	NT12B-BS	125	Vespa GTV	'06→'08	YTX12-BS-N	NTX12-BS
125	Fly 4T 3V IE Euro 3 DT	'13→'15	YTX7L-BS-N	NTX7L-BS	125	Vespa GTV 4T Navy Euro 3	'08	YTX12-BS-N	NTX12-BS
125	Fly Euro 3	'07	YB9-B WA-N	NB9-B WA	125	Vespa LX	'05→'06	YB9-B WA-N	NB9-B WA
125	Fly Euro 3	'08→'11	YB9-B WA-N	NB9-B WA	125	Vespa LX 4T 3V IE Touring	'12→'13	YTX12-BS-N	NTX12-BS
125	Hexagon	'94→'97	YB9-B WA-N	NB9-B WA	125	Vespa LX 4T Euro 3 Touring	'10→'11	YTX12-BS-N	NTX12-BS
125	Hexagon LX-LXT	'98→'99	YB9-B WA-N	NB9-B WA	125	Vespa LX 4T FL	'09	YTX12-BS-N	NTX12-BS
125	Liberty	'98→'00	YB9-B WA-N	NB9-B WA	125	Vespa LX EURO 3	'06→'08	YTX12-BS-N	NTX12-BS
125	Liberty	'01→'02	YB9-B WA-N	NB9-B WA	125	Vespa LX Euro 3 IE	'09→'11	YTX12-BS-N	NTX12-BS
125	Liberty 4T	'06→'07	YB9-B WA-N	NB9-B WA	125	Vespa LX Prim. 4T 3V IE	'13→'17	YTX7L-BS-N	NTX7L-BS
125	Liberty 4T 2V Euro 3	'09→'12	YTX12-BS-N	NTX12-BS	125	Vespa LXV 4T Euro 3	'06→'09	YTX12-BS-N	NTX12-BS
125	Liberty 4T 2V IE PTT - ITA	'12→'13	YTX12-BS-N	NTX12-BS	125	Vespa LXV 4T Navy Euro 3	'07→'08	YTX12-BS-N	NTX12-BS
125	Liberty 4T 3V IE Euro 3	'15	YTX7L-BS-N	NTX7L-BS	125	Vespa LXV IE 4T	'10→'13	YTX12-BS-N	NTX12-BS
125	Liberty 4T 3V IE Euro 3	'13→'14	YTX7L-BS-N	NTX7L-BS	125	Vespa Prim. 4T 3V Euro 4 Iget ABS	'16→'19	YTX7L-BS-N	NTX7L-BS
125	Liberty 4T Euro 3 Delivery - Single	'06→'08	YTX12-BS-N	NTX12-BS	125	Vespa PX	'98→'01	YB9-B WA-N	NB9-B WA
125	Liberty 4T Euro 3 Delivery - Single	'07→'15	YTX12-BS-N	NTX12-BS	125	Vespa PX	'11→'17	YB9-B WA-N	NB9-B WA
125	Liberty 4T Euro 3 Delivery-TNT-Nexive	'08→'15	YB9-B WA-N	NB9-B WA	125	Vespa PX 30 Anni	'07→'08	YB9-B WA-N	NB9-B WA
125	Liberty 4T Euro 3 Delivery-Tnt-Nexive	'08→'15	YTX12-BS-N	NTX12-BS	125	Vespa PX Euro 2	'01→'07	YB9-B WA-N	NB9-B WA
125	Liberty 4T Iget Corporate Euro 4	'17→'19	YTX12-BS-N	NTX12-BS	125	Vespa PX Euro 2	'01→'07	YB9-B WA-N	NB9-B WA
125	Liberty 4T Sport Euro 3	'06→'08	YTX12-BS-N	NTX12-BS	125	Vespa PX T5	'85→'89	YB5L-B WA-N	NB5L-B WA
125	Liberty Iget 4T 3V IE	'15→'19	YTX7L-BS-N	NTX7L-BS	125	Vespa PX T5	'85→'89	YB9-B WA-N	NB9-B WA
125	Liberty RST	'04→'05	YB9-B WA-N	NB9-B WA	125	Vespa PXE	'81→'97	YB9-B WA-N	NB9-B WA
125	Liberty RST PTT	'05→'11	YB9-B WA-N	NB9-B WA					
125	Liberty Sport	'06→'06	YB9-B WA-N	NB9-B WA					
125	Medley 4T IE ABS	'16→'19	YTX7L-BS-N	NTX7L-BS					

BATTERIE / BATTERY

CC	Modello Model	Anno Years	Vecchio Codice Old Code	Nuovo Codice New Code	CC	Modello Model	Anno Years	Vecchio Codice Old Code	Nuovo Codice New Code
125	Vespa S 4T 3V IE	'12	YTX12-BS-N	NTX12-BS	200	Carnaby	'07→'08	YTX14-BS-N	NTX14-BS
125	Vespa S 4T Euro 3	'07→'08	YTX12-BS-N	NTX12-BS	200	Liberty 4T Euro 3	'06→'08	YTX12-BS-N	NTX12-BS
125	Vespa S 4T IE & College	'09→'11	YTX12-BS-N	NTX12-BS	200	Liberty 4T Sport Euro 3	'06→'07	YTX12-BS-N	NTX12-BS
125	Vespa Sprint 4T 3V IE	'14→'15	YTX7L-BS-N	NTX7L-BS	200	Liberty Sport	'06	YTX12-BS-N	NTX12-BS
125	Vespa Sprint Iget 4T 3V ABS	'16→'19	YTX7L-BS-N	NTX7L-BS	250	BEVERLY	'05→'07	YTX14-BS-N	NTX14-BS
125	X EVO	'07→'16	YTX12-BS-N	NTX12-BS	250	Beverly Cruiser	'07→'09	YTX14-BS-N	NTX14-BS
125	X EVO	'07→'16	YTX14-BS-N	NTX14-BS	250	Bev. Euro 3 MIC	'07	YTX14-BS-N	NTX14-BS
125	X10 4T 4V IE Euro 3	'12→'15	YTX12-BS-N	NTX12-BS	250	Beverly Tourer Euro 3	'07→'09	YTX14-BS-N	NTX14-BS
125	X7 Euro 3	'08	YTX12-BS-N	NTX12-BS	250	Carnaby	'08→'09	YTX14-BS-N	NTX14-BS
125	X7 EVO IE Euro 3	'09→'10	YTX12-BS-N	NTX12-BS	250	MP3	'06→'08	YTX14-BS-N	NTX14-BS
125	X8 Premium Euro 3	'06→'07	YTX14-BS-N	NTX14-BS	250	MP3 LT	'08→'09	YTX14-BS-N	NTX14-BS
125	X9 Evolution	'03	YB9-B WA-N	NB9-B WA	250	MP3 MIC	'08→'09	YTX14-BS-N	NTX14-BS
125	X9 Evolution	'05→'06	YB9-B WA-N	NB9-B WA	250	Vespa GTS	'05→'14	YTX14-BS-N	NTX14-BS
125	ZIP	'00→'02	YTX9-BS-N	NTX9-BS	250	Vespa GTV 4T Navy Euro 3	'07	YTX14-BS-N	NTX14-BS
150	Fly	'05→'07	YB9-B WA-N	NB9-B WA	250	X EVO	'07→'13	YTX14-BS-N	NTX14-BS
150	Fly Euro 3	'08→'11	YB9-B WA-N	NB9-B WA	250	X7 Euro 3	'08	YTX14-BS-N	NTX14-BS
150	Liberty 4T 3V LEM	'13→'14	YTX7L-BS-N	NTX7L-BS	250	X8 Euro 3	'05→'08	YTX14-BS-N	NTX14-BS
150	Libert. 4T EURO 3	'08	YTX12-BS-N	NTX12-BS	300	Beverly IE ABS Euro 4	'16→'19	YTX12-BS-N	NTX12-BS
150	Liberty 4T Sport Euro 3	'08	YTX12-BS-N	NTX12-BS	300	Beverly RST 4T 4V IE Euro 3	'10→'16	YTX12-BS-N	NTX12-BS
150	Liberty Iget 4T 3V IE	'15→'19	YTX7L-BS-N	NTX7L-BS	300	Beverly Tourer Euro 3	'09→'10	YTX14-BS-N	NTX14-BS
150	Liberty MOC 4T Euro 3	'09→'13	YTX12-BS-N	NTX12-BS	300	Carnaby Cruiser	'09→'12	YTX12-BS-N	NTX12-BS
150	Medley 4T IE ABS	'16→'20	YTX7L-BS-N	NTX7L-BS	300	MP3 4T 4V IE ERL Ibrido	'10→'13	YTX14-BS-N	NTX14-BS
150	Medley S 4T IE ABS	'16→'20	YTX7L-BS-N	NTX7L-BS	300	MP3 4T 4V IE LT Ibrido	'10→'11	YTX14-BS-N	NTX14-BS
150	Vespa ET4	'99→'02	YB9-B WA-N	NB9-B WA	300	MP3 HPE Euro 4 ABS - Sport	'19	YTX12-BS-N	NTX12-BS
150	Vespa ET4	'99→'02	YTX9-BS-N	NTX9-BS	300	MP3 IE Euro 4 LT Business-Sp. ABS	'16→'18	YTX14-BS-N	NTX14-BS
150	Vespa GTS 4T Euro 4 ABS	'16→'17	YTX7L-BS-N	NTX7L-BS	300	MP3 IE LT	'10→'11	YTX14-BS-N	NTX14-BS
150	Vespa GTS Super IE 4T 3V	'14→'15	YTX7L-BS-N	NTX7L-BS	300	MP3 IE LT- IE LT Sport	'11→'14	YTX14-BS-N	NTX14-BS
150	Vespa LT 4T 3V IE	'14	YTX7L-BS-N	NTX7L-BS	300	MP3 IE LT Tour.	'11→'13	YTX14-BS-N	NTX14-BS
150	Vespa LX	'05→'06	YB9-B WA-N	NB9-B WA	300	MP3 IE MIC	'10→'10	YTX14-BS-N	NTX14-BS
150	Vespa LX 4T 3V IE Touring	'12→'13	YTX12-BS-N	NTX12-BS	300	MP3 IE MIC	'11	YTX14-BS-N	NTX14-BS
150	Vespa LX 4T 3V IE Touring	'12→'13	YTX7L-BS-N	NTX7L-BS	300	MP3 IE Touring	'11→'12	YTX14-BS-N	NTX14-BS
150	Vespa LX 4T FL	'09	YTX12-BS-N	NTX12-BS	300	MP3 LT Business Sport ABS - Enjoy	'14→'16	YTX14-BS-N	NTX14-BS
150	Vespa LX Euro 3	'06→'08	YTX12-BS-N	NTX12-BS	300	MP3 Yourban ERL	'11→'15	YTX14-BS-N	NTX14-BS
150	Vespa LX Euro 3 IE	'09→'11	YTX12-BS-N	NTX12-BS	300	MP3 Yourban LT ERL	'11→'16	YTX14-BS-N	NTX14-BS
150	Vespa LX Touring	'10→'12	YTX12-BS-N	NTX12-BS	300	MP3 Yourban LT RL Euro 4	'17→'18	YTX12-BS-N	NTX12-BS
150	Vespa Primavera 4T 3V Iget ABS	'16→'19	YTX7L-BS-N	NTX7L-BS	300	MP3 Yourban LT RL Euro 4	'17→'18	YTX14-BS-N	NTX14-BS
150	Vespa Primavera 4T-3V	'13→'16	YTX7L-BS-N	NTX7L-BS	300	Vespa GTS - GTS Super IE ABS Euro 4	'16→'18	YTX12-BS-N	NTX12-BS
150	Vespa PX	'11→'17	YB9-B WA-N	NB9-B WA	300	Vespa GTS HPE 4T/4V IE ABS Euro 4	'19	YTX12-BS-N	NTX12-BS
150	Vespa S 4T	'08→'09	YTX12-BS-N	NTX12-BS	300	Vespa GTS IE & Touring	'12→'16	YTX12-BS-N	NTX12-BS
150	Vespa S 4T IE & College	'0912	YTX12-BS-N	NTX12-BS	300	Vespa GTS IE Touring	'11→'12	YTX12-BS-N	NTX12-BS
150	Vespa Sprint 4T 3V IE	'15	YTX7L-BS-N	NTX7L-BS	300	Vespa GTS Super	'08→'16	YTX12-BS-N	NTX12-BS
150	Vespa Sprint Spr. 4T 3V Iget ABS	'16→'19	YTX7L-BS-N	NTX7L-BS	300	Vespa GTS Sup.	'08→'16	YTX14-BS-N	NTX14-BS
180	Hexagon LX-LXT	'98→'99	YB9-B WA-N	NB9-B WA					

BATTERIE / BATTERY

CC	Modello Model	Anno Years	Vecchio Codice Old Code	Nuovo Codice New Code
300	Vespa GTS Super HPE 4T/4V IE ABS	'18→'19	YTX12-BS-N	NTX12-BS
300	Vespa GTS Super Sport	'10→'13	YTX12-BS-N	NTX12-BS
300	Vespa GTV 4T 4V IE	'10→'13	YTX12-BS-N	NTX12-BS
300	Vespa GTV Sei Giorni IE Euro 4 ABS	'19→'20	YTX12-BS-N	NTX12-BS
300	Vespa GTV Sei Giorni IE Euro 4 ABS	'17	YTX12-BS-N	NTX12-BS
300	Vespa GTV Via Montenapoleone	'10	YTX12-BS-N	NTX12-BS
300	X7 EVO IE Euro 3	'09→'12	YTX12-BS-N	NTX12-BS
350	Beverly 4T 4V IE Euro 3 Sport Touring	'11→'14	YTX12-BS-N	NTX12-BS
350	Beverly 4T 4V IE Euro3 Sport Touring ABS	'11→'14	YTX12-BS-N	NTX12-BS
350	Bev. 4T ST IE ABS	'16→'19	YTX12-BS-N	NTX12-BS
350	MP3 Maxi Sport Euro 4 ABS	'18→'19	YTX14-BS-N	NTX14-BS
350	X10 4T 4V IE Euro 3	'12→'15	YTX12-BS-N	NTX12-BS
400	Beverly Euro 3	'06→'07	YTX14-BS-N	NTX14-BS
400	Beverly Tourer Euro 3	'08→'10	YTX14-BS-N	NTX14-BS
400	MP3	'07→'08	YTX14-BS-N	NTX14-BS
400	MP3 IE LT - MP3 IE LT Sport	'08→'10	YTX14-BS-N	NTX14-BS
400	MP3 IE LT Tour.	'11	YTX14-BS-N	NTX14-BS
400	MP3 MIC	'08→'10	YTX14-BS-N	NTX14-BS
400	MP3 RL Touring	'11	YTX14-BS-N	NTX14-BS
400	X EVO	'07→'11	YTX14-BS-N	NTX14-BS
500	Beverly	'05→'06	YTX14-BS-N	NTX14-BS
500	Beverly Cruiser	'07→'12	YTX14-BS-N	NTX14-BS
500	Beverly Euro 3	'06→'08	YTX14-BS-N	NTX14-BS
500	MP3 LT Business ABS	'14→'18	YTX14-BS-N	NTX14-BS
500	MP3 LT Euro 4 Sport-Business	'16→'18	YTX14-BS-N	NTX14-BS
500	MP3 LT Sport - Business	'11→'13	YTX14-BS-N	NTX14-BS
500	MP3 Maxi Sport - Bus. Euro 4 ABS	'18	YTX14-BS-N	NTX14-BS
500	MP3 RL Sport Business	'11→'12	YTX14-BS-N	NTX14-BS
500	MP3 Sport ABS	'14→'16	YTX14-BS-N	NTX14-BS
500	X10 4T 4V IE Euro 3	'12→'14	YTX14-BS-N	NTX14-BS
500	X9	'01→'02	YB14L-A2 WA-N	NB14L-A2 WA
500	X9 Evolution	'03→'05	YB14L-A2 WA-N	NB14L-A2 WA
500	X9 Evolution	'06→'07	YB14L-A2 WA-N	NB14L-A2 WA
500	X9 Evolution ABS	'06→'07	YB14L-A2 WA-N	NB14L-A2 WA

POLARIS

0	90 Outlaw	'16	YTX5L-BS-N	NTX5L-BS
50	Outlaw	'08→'18	YTX5L-BS-N	NTX5L-BS
50	Predator	'04→'07	YTX5L-BS-N	NTX5L-BS
50	Scrambler	'01→'03	YTX5L-BS-N	NTX5L-BS

CC	Modello Model	Anno Years	Vecchio Codice Old Code	Nuovo Codice New Code
90	Outlaw	'07→'15	YTX5L-BS-N	NTX5L-BS
90	Predator	'03→'06	YTX5L-BS-N	NTX5L-BS
90	Scrambler X	'01→'03	YTX5L-BS-N	NTX5L-BS
90	Sportsman	'01→'16	YTX5L-BS-N	NTX5L-BS
170	RZR Ranger	'09→'14	YTX12-BS-N	NTX12-BS
200	EA/EB Phoenix Quadricycle	'05	YTX12-BS-N	NTX12-BS
200	EC/ED Phoenix Quadricycle	'05→'10	YTX12-BS-N	NTX12-BS
200	Phoenix	'05→'08	YTX12-BS-N	NTX12-BS
200	Phoenix	'05→'08	YTX12-BS-N	NTX12-BS
200	Phoenix	'09→'11	YTX12-BS-N	NTX12-BS
200	Phoenix	'12→'14	YTX12-BS-N	NTX12-BS
200	Sawtooth	'06→'08	YTX12-BS-N	NTX12-BS
200	Sawtooth Quadricycle	'06→'08	YTX12-BS-N	NTX12-BS
450	MXR Outlaw	'09→'10	YTX9-BS-N	NTX9-BS
450	S Outlaw	'08→'10	YTX9-BS-N	NTX9-BS
500	Outlaw	'06→'07	YTX9-BS-N	NTX9-BS
500	TLD Predator	'03→'07	YTX9-BS-N	NTX9-BS
525	IRS Outlaw	'08→'11	YTX9-BS-N	NTX9-BS
525	S Outlaw	'08→'10	YTX9-BS-N	NTX9-BS

RIEJU

50	RS2 FR	'09→'10	YT4L-BS-N	NT4L-BS
50	RS2 Matrix	'02→'10	YT4L-BS-N	NT4L-BS
50	RS2 NKD	'05→'05	YT4L-BS-N	NT4L-BS
50	RS2 NKD	'05→'05	YT4L-BS-N	NT4L-BS
50	RS2 PRO	'06→'10	YT4L-BS-N	NT4L-BS
50	RS3	'11→'16	YT4L-BS-N	NT4L-BS
50	RS3 NKD	'12→'16	YT4L-BS-N	NT4L-BS
50	RS3 PRO	'11→'17	YT4L-BS-N	NT4L-BS
125	Marathon	'09→'20	YTX5L-BS-N	NTX5L-BS
125	Marathon PRO	'09→'20	YTX5L-BS-N	NTX5L-BS
125	Marathon Pro Competizione	'11→'14	YTX5L-BS-N	NTX5L-BS
125	Marathon PRO Supermotard	'09→'20	YTX5L-BS-N	NTX5L-BS
125	Marathon Supermotard	'10→'20	YTX5L-BS-N	NTX5L-BS
125	RS3 NKD	'11→'15	YTX5L-BS-N	NTX5L-BS
125	RS3 Sport	'11→'16	YTX5L-BS-N	NTX5L-BS
125	Tango	'11→'15	YTX5L-BS-N	NTX5L-BS

ROYAL ENFIELD

400	Himalayan 411	'16→'20	YTX9-BS-N	NTX9-BS
535	Continental GT	'13→'16	YB14L-A2 WA-N	NB14L-A2 WA
535	Contin. GT ABS	'17→'18	YB14L-A2 WA-N	NB14L-A2 WA

SHERCO

125	SC-R Cross Country 2T	'19→'20	YTX5L-BS-N	NTX5L-BS
125	SE-R Cross Country 2T	'19→'20	YTX5L-BS-N	NTX5L-BS
125	SE-R Enduro	'18	YTX5L-BS-N	NTX5L-BS
125	SE-R Enduro Factory 2T	'18→'20	YTX5L-BS-N	NTX5L-BS
125	SE-R Enduro Racing 2T	'18→'20	YTX5L-BS-N	NTX5L-BS
250	2.5 HF Enduro	'08	YT7B-BS-N	NT7B-BS
250	SCF-R Cross	'19→'20	YTX5L-BS-N	NTX5L-BS

BATTERIE / BATTERY

CC	Modello Model	Anno Years	Vecchio Codice Old Code	Nuovo Codice New Code	CC	Modello Model	Anno Years	Vecchio Codice Old Code	Nuovo Codice New Code
	Country 4T				50	AJ ZZ Sepia	'92-'92	YT4L-BS-N	NT4L-BS
250	SC-R Cross	'19-'20	YTX5L-BS-N	NTX5L-BS	50	AP	'75-'78	YT4L-BS-N	NT4L-BS
	Country 2T				50	AP	'94-'96	YB4L-B WA-N	NB4L-B WA
250	SE 2.5 I-F Enduro	'09-'11	YT7B-BS-N	NT7B-BS	50	AP	'97-'02	YT4L-BS-N	NT4L-BS
250	SE Enduro	'14-'18	YTX5L-BS-N	NTX5L-BS	50	AY Katana	'97-'00	YB4L-B WA-N	NB4L-B WA
250	SE I-F Enduro	'12-'13	YTX5L-BS-N	NTX5L-BS	50	AY Katana	'01-'04	YT4L-BS-N	NT4L-BS
250	SEF Enduro	'14-'18	YTX5L-BS-N	NTX5L-BS	50	AY WR	'01-'05	YT4L-BS-N	NT4L-BS
250	SEF R Enduro	'14-'18	YTX5L-BS-N	NTX5L-BS	50	AY WR Katana	'99-'00	YB4L-B WA-N	NB4L-B WA
250	SEF-R Enduro	'17-'20	YTX5L-BS-N	NTX5L-BS	50	AY WR Katana	'01-'04	YT4L-BS-N	NT4L-BS
	Factory 4T				50	CL Suzi	'83-'83	YB4L-B WA-N	NB4L-B WA
250	SEF-R Enduro	'14-'20	YTX5L-BS-N	NTX5L-BS	50	CP CH	'85-'85	YB4L-B WA-N	NB4L-B WA
	Racing 4T				50	CS Roadie	'83-'84	YB4L-B WA-N	NB4L-B WA
250	SE-R Enduro	'14-'18	YTX5L-BS-N	NTX5L-BS	50	GS	'05-'05	YT4L-BS-N	NT4L-BS
250	SE-R Enduro	'17-'20	YTX5L-BS-N	NTX5L-BS	50	LT-A Quadmaster	'06-'18	YTX5L-BS-N	NTX5L-BS
	Factory 2T				50	RG W	'83	YB4L-B WA-N	NB4L-B WA
250	SE-R Enduro	'14-'20	YTX5L-BS-N	NTX5L-BS	50	TS W	'86-'86	YB4L-B WA-N	NB4L-B WA
	Racing 2T				50	TS X	'90-'96	YB4L-B WA-N	NB4L-B WA
300	SCF-R Cross	'19-'20	YTX5L-BS-N	NTX5L-BS	50	TS XK	'84-'02	YB4L-B WA-N	NB4L-B WA
	Country 4T				50	TV	'91	YB4L-B WA-N	NB4L-B WA
300	SC-R Cross	'19-'20	YTX5L-BS-N	NTX5L-BS	50	TV	'94-'94	YB4L-B WA-N	NB4L-B WA
	Country 2T				50	UX W Zillion	'99-'02	YT4L-BS-N	NT4L-BS
300	SE 3 I Enduro	'10-'11	YT7B-BS-N	NT7B-BS	50	X5 Choinori	'03-'03	YT4L-BS-N	NT4L-BS
300	SE I	'14-'18	YTX5L-BS-N	NTX5L-BS	80	CP CHF	'85-'93	YB5L-B WA-N	NB5L-B WA
300	SE I-F Enduro	'12-'13	YTX5L-BS-N	NTX5L-BS	80	LT	'87-'95	YTX5L-BS-N	NTX5L-BS
300	SEF Enduro	'14-'18	YTX5L-BS-N	NTX5L-BS	80	LT Quad Sport	'96-'06	YTX5L-BS-N	NTX5L-BS
300	SEF R Enduro	'14-'18	YTX5L-BS-N	NTX5L-BS	80	RG	'80-'81	YB4L-B WA-N	NB4L-B WA
300	SEF-R Enduro	'17-'20	YTX5L-BS-N	NTX5L-BS	80	RG Gamma	'84-'93	YB4L-B WA-N	NB4L-B WA
	Factory 4T				80	TS X / RH	'84-'88	YB4L-B WA-N	NB4L-B WA
300	SEF-R Enduro	'14-'20	YTX5L-BS-N	NTX5L-BS	90	FB Quadsport	'01-'01	YT4L-BS-N	NT4L-BS
	Racing 4T				90	LT-Z Quadsport	'07-'16	YTX7A-BS-N	NTX7A-BS
300	SE-R Enduro	'14-'18	YTX5L-BS-N	NTX5L-BS	100	AH Address	'92-'94	YTX5L-BS-N	NTX5L-BS
300	SE-R Enduro	'17-'20	YTX5L-BS-N	NTX5L-BS	100	AH P Address	'95-'96	YTX5L-BS-N	NTX5L-BS
	Factory 2T				110	UG Address	'98-'02	YTX5L-BS-N	NTX5L-BS
300	SE-R Enduro	'14-'20	YTX5L-BS-N	NTX5L-BS	125	AN	'95-'00	YTX7A-BS-N	NTX7A-BS
	Racing 2T				125	DR S	'82-'88	YB4L-B WA-N	NB4L-B WA
450	4.5 I Enduro	'04-'08	YT7B-BS-N	NT7B-BS	125	DR S	'89-'94	YT4L-BS-N	NT4L-BS
450	SCF-R Cross	'19-'20	YTX5L-BS-N	NTX5L-BS	125	DR SE	'94-'01	YTX7L-BS-N	NTX7L-BS
	Country				125	DR SM	'08-'13	YTX7L-BS-N	NTX7L-BS
450	SE 4.5 I-F Enduro	'09-'11	YT7B-BS-N	NT7B-BS	125	GT	'74-'81	YB5L-B WA-N	NB5L-B WA
450	SE I-R End. 4.5I	'12-'13	YT7B-BS-N	NT7B-BS	125	GT X4	'80	YB5L-B WA-N	NB5L-B WA
450	SEF	'15-'18	YTX5L-BS-N	NTX5L-BS	125	GZ Marauder	'98-'11	YTX7L-BS-N	NTX7L-BS
450	SEF-R	'15-'18	YTX5L-BS-N	NTX5L-BS	125	RG BU Gamma	'88	YB4L-B WA-N	NB4L-B WA
450	SEF-R Enduro	'17-'20	YTX5L-BS-N	NTX5L-BS	125	RG C Gamma	'86-'90	YB4L-B WA-N	NB4L-B WA
	Factory				125	RG F Gamma	'92-'94	YTX7L-BS-N	NTX7L-BS
450	SEF-R Enduro	'15-'20	YTX5L-BS-N	NTX5L-BS	125	RG FU Gamma	'92-'95	YTX7L-BS-N	NTX7L-BS
	Racing				125	RG Gamma	'88	YB4L-B WA-N	NB4L-B WA
500	SCF-R Cross	'19-'20	YTX5L-BS-N	NTX5L-BS	125	RG U Wolf	'92-'95	YTX7L-BS-N	NTX7L-BS
	Country				125	RG UC	'86-'88	YB4L-B WA-N	NB4L-B WA
500	SEF-R Enduro	'19-'20	YTX5L-BS-N	NTX5L-BS	125	RV Van-Van	'02-'17	YTX7L-BS-N	NTX7L-BS
	Factory				125	TS ER	'82-'82	YB4L-B WA-N	NB4L-B WA
500	SEF-R Enduro	'19-'20	YTX5L-BS-N	NTX5L-BS	125	TS R	'90-'96	YT4L-BS-N	NT4L-BS
	Racing				125	TS X	'84	YB4L-B WA-N	NB4L-B WA
510	5.1 I Enduro	'06-'08	YT7B-BS-N	NT7B-BS	125	TS XU	'86-'90	YB4L-B WA-N	NB4L-B WA
510	SE 5.1 I-F Enduro	'09-'11	YT7B-BS-N	NT7B-BS	125	UC	'99-'00	YTX7A-BS-N	NTX7A-BS
510	SE 5.1 I-R Enduro	'12-'13	YT7B-BS-N	NT7B-BS	125	UH Burgman	'02-'16	YTX9-BS-N	NTX9-BS
510	SM 5.1 I-F	'12-'13	YT7B-BS-N	NT7B-BS	125	UH Burg. ABS	'14-'20	YTX9-BS-N	NTX9-BS
					125	UX Sixteen	'08-'14	YTX7L-BS-N	NTX7L-BS
					125	UZ V125G	'05-'05	YTX7L-BS-N	NTX7L-BS
					125	VL Intruder	'99-'08	YTX7L-BS-N	NTX7L-BS
					150	UE CT	'01-'01	YTX7A-BS-N	NTX7A-BS
					150	UH Burgman	'02-'06	YTX9-BS-N	NTX9-BS
					150	UX Sixteen	'08-'14	YTX7L-BS-N	NTX7L-BS

SUZUKI

50	AD T Tune	'88-'88	YT4L-BS-N	NT4L-BS
50	AE R	'90	YT4L-BS-N	NT4L-BS
50	AE Style	'90-'96	YT4L-BS-N	NT4L-BS
50	AH N Adress	'92-'95	YT4L-BS-N	NT4L-BS

BATTERIE / BATTERY

CC	Modello Model	Anno Years	Vecchio Codice Old Code	Nuovo Codice New Code	CC	Modello Model	Anno Years	Vecchio Codice Old Code	Nuovo Codice New Code
200	DR	'86→'89	YB4L-B WA-N	NB4L-B WA	400	LT-F F Eiger	'02→'07	YTX14-BS-N	NTX14-BS
200	DR SE	'93→'13	YTX7L-BS-N	NTX7L-BS	400	LT-F F King Quad	'08→'12	YTX14-BS-N	NTX14-BS
200	RV	'02→'03	YTX7L-BS-N	NTX7L-BS	400	LT-Z	'02→'18	YTX9-BS-N	NTX9-BS
200	RV Van-Van	'16→'19	YTX7L-BS-N	NTX7L-BS	450	LT-A X Kingquad	'07→'10	YTX14-BS-N	NTX14-BS
200	TS R	'89→'94	YT4L-BS-N	NT4L-BS	450	LT-R Quadracer	'06→'12	YTX7A-BS-N	NTX7A-BS
200	UH Burgman	'07→'16	YTX9-BS-N	NTX9-BS	450	LT-R Quadracer	'11→'11	YTX7A-BS-N	NTX7A-BS
200	UH Burg. ABS	'14→'20	YTX9-BS-N	NTX9-BS	450	RM-X Z	'10→'17	YTZ7S-BS-N	NTZ7S-BS
230	LT E Quad Run.	'88→'93	YTX12-BS-N	NTX12-BS	500	RG Gamma	'86→'89	YTX5L-BS-N	NTX5L-BS
250	AN Burgman	'98→'99	YTX7A-BS-N	NTX7A-BS	600	DR R Dakar	'86→'89	YB5L-B WA-N	NB5L-B WA
250	AN Burgman	'00→'02	YTX9-BS-N	NTX9-BS	600	DR S	'85→'89	YB5L-B WA-N	NB5L-B WA
250	AN Burgman	'03→'06	YT12A-BS-N	NT12A-BS	600	GSF Bandit	'95→'04	YTX9-BS-N	NTX9-BS
250	AN M Skywave	'07→'08	YTX12-BS-N	NTX12-BS	600	GSF Bandit S	'96→'04	YTX9-BS-N	NTX9-BS
250	AN SS Skywave	'08	YTX12-BS-N	NTX12-BS	600	GSR	'06→'10	YTX9-BS-N	NTX9-BS
250	DL V-Strom	'17→'20	YTX9-BS-N	NTX9-BS	600	GSX F	'98→'06	YTX9-BS-N	NTX9-BS
250	DR	'90→'93	YT4L-BS-N	NT4L-BS	600	GSX-R	'97→'17	YTX9-BS-N	NTX9-BS
250	DR R	'98→'00	YTX5L-BS-N	NTX5L-BS	600	RF R	'93→'97	YTX9-BS-N	NTX9-BS
250	DR S	'82→'87	YB4L-B WA-N	NB4L-B WA	650	AN Burgman	'02→'17	YTX14-BS-N	NTX14-BS
250	DR S	'90→'92	YT4L-BS-N	NT4L-BS	650	AN Burgman ABS	'17→'18	YTX14-BS-N	NTX14-BS
250	DR SE	'93→'95	YTX7L-BS-N	NTX7L-BS	650	AN Burgman	'04→'12	YTX14-BS-N	NTX14-BS
250	DR-Z	'01→'07	YTX5L-BS-N	NTX5L-BS		Executive ABS			
250	GSF Bandit	'92→'93	YTX7A-BS-N	NTX7A-BS	650	AN Burgman	'13→'20	YTX14-BS-N	NTX14-BS
250	GSF V Bandit	'95→'00	YTX7A-BS-N	NTX7A-BS		Executive ABS			
250	GSX F Across	'90→'98	YTX7A-BS-N	NTX7A-BS	650	DL V-Strom	'04→'06	YTX12-BS-N	NTX12-BS
250	GSX-R	'17→'20	YTX9-BS-N	NTX9-BS	650	DL V-Strom ABS	'07→'20	YTX12-BS-N	NTX12-BS
250	GT	'73→'78	YB5L-B WA-N	NB5L-B WA	650	DL V-Strom	'07→'11	YTX12-BS-N	NTX12-BS
250	GT X7	'78→'81	YB5L-B WA-N	NB5L-B WA		Traveller ABS			
250	GW Inazuma	'13→'15	YTX9-BS-N	NTX9-BS	650	DL V-Strom	'11	YTX12-BS-N	NTX12-BS
250	GZ	'99→'01	YTX7L-BS-N	NTX7L-BS		Xpedition ABS			
250	GZ Marauder	'02→'08	YTX7L-BS-N	NTX7L-BS	650	DL X V-Strom	'07→'11	YTX12-BS-N	NTX12-BS
250	LT-F F	'99→'02	YTX12-BS-N	NTX12-BS	650	DL X V-Strom	'15→'20	YTX12-BS-N	NTX12-BS
250	LT-F Ozark	'02→'14	YTX12-BS-N	NTX12-BS		XT ABS			
250	LT-R Quadracer	'91→'92	YTX12-BS-N	NTX12-BS	650	DR R	'90→'91	YB5L-B WA-N	NB5L-B WA
250	LT-Z Quadsport	'04→'12	YTX9-BS-N	NTX9-BS	650	DR R	'92→'93	YT4L-BS-N	NT4L-BS
250	RG F	'85→'88	YB5L-B WA-N	NB5L-B WA	650	DR RE	'94→'95	YTX12-BS-N	NTX12-BS
250	RG W	'83→'84	YB5L-B WA-N	NB5L-B WA	650	DR RS	'90→'91	YB5L-B WA-N	NB5L-B WA
250	RGV	'88→'96	YT4L-BS-N	NT4L-BS	650	DR RSE	'91→'96	YTX14-BS-N	NTX14-BS
250	T	'70→'72	YB5L-B WA-N	NB5L-B WA	650	DR SE	'96→'06	YTX9-BS-N	NTX9-BS
250	TS X	'84→'89	YB4L-B WA-N	NB4L-B WA	650	GR	'83→'85	YB14L-A2 WA-N	NB14L-A2 WA
250	VL Intruder	'00→'07	YTX7L-BS-N	NTX7L-BS	650	GS G Katana	'81→'83	YB14L-A2 WA-N	NB14L-A2 WA
350	DR S	'90→'93	YT4L-BS-N	NT4L-BS	650	GSF N Bandit	'05→'15	YTX9-BS-N	NTX9-BS
350	DR SE	'94→'99	YTX7L-BS-N	NTX7L-BS	650	GSF N Band. ABS	'05→'15	YTX9-BS-N	NTX9-BS
350	T	'69→'72	YB5L-B WA-N	NB5L-B WA	650	GSF S Bandit	'05→'13	YTX9-BS-N	NTX9-BS
400	AN Burgman	'99→'00	YTX9-BS-N	NTX9-BS	650	GSF S Band. ABS	'05→'15	YTX9-BS-N	NTX9-BS
400	AN Burgman	'01→'02	YTX9-BS-N	NTX9-BS	650	GSX- F	'08→'16	YTX9-BS-N	NTX9-BS
400	AN Burgman	'03→'06	YT12A-BS-N	NT12A-BS	650	GSX- F ABS	'08→'15	YTX9-BS-N	NTX9-BS
400	AN Burgman	'07→'15	YTX9-BS-N	NTX9-BS	650	SFV Gladius	'09→'16	YT12A-BS-N	NT12A-BS
400	AN Burgman	'09→'16	YTX9-BS-N	NTX9-BS	650	SFV Gladius ABS	'09→'16	YT12A-BS-N	NT12A-BS
	Executive				650	SV ABS	'16→'20	YT12A-BS-N	NT12A-BS
400	AN Burgman	'09→'19	YTX9-BS-N	NTX9-BS	650	SV N	'99→'02	YT12A-BS-N	NT12A-BS
	Executive ABS				650	SV N	'03→'10	YTX12-BS-N	NTX12-BS
400	DR-Z	'00→'07	YT7B-BS-N	NT7B-BS	650	SV N ABS	'07→'10	YT12A-BS-N	NT12A-BS
400	DR-Z E	'00→'07	YT7B-BS-N	NT7B-BS	650	SV S	'99→'02	YT12A-BS-N	NT12A-BS
400	DR-Z S	'00→'14	YT7B-BS-N	NT7B-BS	650	SV S	'03→'11	YTX12-BS-N	NTX12-BS
400	DR-Z SE	'01→'01	YT7B-BS-N	NT7B-BS	650	SV S ABS	'07→'10	YT12A-BS-N	NT12A-BS
400	DR-Z SM	'05→'09	YT7B-BS-N	NT7B-BS	650	SV X ABS	'18→'20	YT12A-BS-N	NT12A-BS
400	GSF Bandit	'89→'97	YTX9-BS-N	NTX9-BS	650	XF Freewind	'97→'02	YTX9-BS-N	NTX9-BS
400	GSR	'06→'06	YTX9-BS-N	NTX9-BS	650	XN 85 Turbo	'83→'83	YB14L-A2 WA-N	NB14L-A2 WA
400	GSX-R R	'90→'95	YTX9-BS-N	NTX9-BS	700	GS E	'85	YB14L-A2 WA-N	NB14L-A2 WA
400	LT-A F Eiger	'02→'07	YTX14-BS-N	NTX14-BS	750	GS	'77	YB14L-A2 WA-N	NB14L-A2 WA
400	LT-A F King	'08→'12	YTX14-BS-N	NTX14-BS	750	GS D	'77→'78	YB14L-A2 WA-N	NB14L-A2 WA
	Quad Auto				750	GS E	'78→'79	YB14L-A2 WA-N	NB14L-A2 WA
400	LT-F Eiger	'02→'07	YTX14-BS-N	NTX14-BS	750	GSR	'11→'16	YT12A-BS-N	NT12A-BS

BATTERIE / BATTERY

CC	Modello Model	Anno Years	Vecchio Codice Old Code	Nuovo Codice New Code
125	Citycom	'08→'13	YTX9-BS-N	NTX9-BS
125	Combiz	'11→'14	YTX7A-BS-N	NTX7A-BS
125	Fiddle II (4T)	'08→'15	YTX7A-BS-N	NTX7A-BS
125	Fiddle III (4T)	'08→'15	YTX7A-BS-N	NTX7A-BS
125	GTS	'06→'07	YTX9-BS-N	NTX9-BS
125	GTS Euro 3	'08	YTX9-BS-N	NTX9-BS
125	GTS EVO	'09→'10	YTX9-BS-N	NTX9-BS
125	GTS I Joymax	'10→'15	YTX9-BS-N	NTX9-BS
125	GTS I Sport	'14→'15	YTX9-BS-N	NTX9-BS
125	HD	'04→'09	YTX9-BS-N	NTX9-BS
125	HD I EVO	'07→'13	YTX9-BS-N	NTX9-BS
125	HD S EVO	'07→'07	YTX9-BS-N	NTX9-BS
125	HD2	'10→'15	YTX9-BS-N	NTX9-BS
125	Jet 14 I	'17	YTX7A-BS-N	NTX7A-BS
125	Jet 4	'10→'17	YTX7A-BS-N	NTX7A-BS
125	Jet V	'12→'13	YTX10S-BS-N	NTZ10S-BS
125	Joyride	'01→'06	YTX9-BS-N	NTX9-BS
125	Joyride EVO I	'09→'15	YTX9-BS-N	NTX9-BS
125	Joyride I	'07→'09	YTX9-BS-N	NTX9-BS
125	Megalo	'00→'07	YTX7A-BS-N	NTX7A-BS
125	MX Euro 1	'02→'07	YTX9-BS-N	NTX9-BS
125	MX Euro 2	'06→'09	YTX9-BS-N	NTX9-BS
125	Orbit II Symply 4T	'09→'15	YTX7A-BS-N	NTX7A-BS
125	RS	'04→'06	YTX9-BS-N	NTX9-BS
125	SB NI Wolf	'11→'15	YTX9-BS-N	NTX9-BS
125	Shark	'99→'02	YTX9-BS-N	NTX9-BS
125	Shark 4VR R	'00→'02	YTX9-BS-N	NTX9-BS
125	Symphony S	'10→'16	YTX7A-BS-N	NTX7A-BS
125	Symphony SR	'10→'15	YTX7A-BS-N	NTX7A-BS
125	Symphony ST	'15→'20	YTX7A-BS-N	NTX7A-BS
125	VS	'06→'15	YTX10S-BS-N	NTZ10S-BS
125	XPro	'13→'15	YTX7A-BS-N	NTX7A-BS
200	HD2 I	'10→'17	YTX9-BS-N	NTX9-BS
200	Joyride	'03→'07	YTX9-BS-N	NTX9-BS
200	Joyride EVO I	'09→'15	YTX9-BS-N	NTX9-BS
200	Joyride I	'07→'09	YTX9-BS-N	NTX9-BS
200	Symphony ST	'18→'20	YTX7A-BS-N	NTX7A-BS
200	Trackrunner	'06→'09	YTX9-BS-N	NTX9-BS
250	Joymax GTS I	'09→'14	YTX12-BS-N	NTX12-BS
250	Joymax I	'07→'08	YTX12-BS-N	NTX12-BS
250	Quadlander	'05→'09	YTX12-BS-N	NTX12-BS
300	Citycom I	'08→'14	YTX12-BS-N	NTX12-BS
300	Joymax GTS	'08→'14	YTX12-BS-N	NTX12-BS
300	Joymax SPORT	'14→'15	YTX12-BS-N	NTX12-BS
300	Quadlander	'08→'10	YTX12-BS-N	NTX12-BS
300	Quadlander S	'07→'15	YTX12-BS-N	NTX12-BS
400	Maxsym I	'11→'16	YTX14S-BS-N	NTZ14S-BS
400	Maxsym I ABS	'17→'20	YTX14S-BS-N	NTZ14S-BS
500	Maxsym TL	'20	YTX10S-BS-N	NTZ10S-BS
600	Maxsym I	'14→'15	YTX14S-BS-N	NTZ14S-BS

TM

125	EN	'11→'16	YTX7L-BS-N	NTX7L-BS
250	EN-F	'09→'10	YTX7L-BS-N	NTX7L-BS
250	EN	'10→'16	YTX7L-BS-N	NTX7L-BS
250	EN-F	'11→'16	YTX7L-BS-N	NTX7L-BS
250	EN FI Enduro	'11→'16	YTX7L-BS-N	NTX7L-BS
300	EN	'10→'16	YTX7L-BS-N	NTX7L-BS
450	EN-F	'03→'10	YTX7L-BS-N	NTX7L-BS
450	EN-F	'11→'16	YTX7L-BS-N	NTX7L-BS
530	EN-F	'04→'16	YTX7L-BS-N	NTX7L-BS

CC	Modello Model	Anno Years	Vecchio Codice Old Code	Nuovo Codice New Code
530	MX-F	'05→'15	YTX7L-BS-N	NTX7L-BS

TRIUMPH

600	Daytona	'03→'04	YTX9-BS-N	NTX9-BS
600	Speed Four	'02→'05	YTX12-BS-N	NTX12-BS
600	TT	'00→'03	YTX12-BS-N	NTX12-BS
650	Daytona	'05→'05	YTX9-BS-N	NTX9-BS
675	Daytona	'06→'10	YT7B-BS-N	NT7B-BS
675	Daytona	'11→'13	YTX9-BS-N	NTX9-BS
675	Daytona ABS	'13→'17	YTX9-BS-N	NTX9-BS
675	Daytona R	'11→'12	YTX9-BS-N	NTX9-BS
675	Daytona R ABS	'13→'17	YTX9-BS-N	NTX9-BS
675	Street Triple	'07→'13	YTX9-BS-N	NTX9-BS
675	Street Triple ABS	'13→'17	YTX9-BS-N	NTX9-BS
675	Street Triple R	'09→'13	YTX9-BS-N	NTX9-BS
675	Street Tr. R ABS	'13→'16	YTX9-BS-N	NTX9-BS
675	Street Tr. RX ABS	'15→'16	YTX9-BS-N	NTX9-BS
750	Daytona	'91→'92	YB14L-A2 WA-N	NB14L-A2 WA
750	Speed Triple	'97	YB14L-A2 WA-N	NB14L-A2 WA
750	T140 Bonneville Harris	'85→'88	YB9-B WA-N	NB9-B WA
750	T140 D Bonnevil.	'79→'81	YB9-B WA-N	NB9-B WA
750	T140 E Bonnevil.	'79→'83	YB9-B WA-N	NB9-B WA
750	T140 E Bonnevil.	'78→'83	YB9-B WA-N	NB9-B WA
750	T140 E/ES Executive	'81→'83	YB9-B WA-N	NB9-B WA
750	T140 ES	'80→'81	YB9-B WA-N	NB9-B WA
750	T140 ES Bonnevil. Roadster E-Starter	'80→'83	YB9-B WA-N	NB9-B WA
750	T140 EX Bonneville Ex.	'81→'83	YB9-B WA-N	NB9-B WA
750	T140 Silver Jubilee Bonneville	'77	YB9-B WA-N	NB9-B WA
750	T140 V Bonnevil.	'73→'78	YB9-B WA-N	NB9-B WA
750	T140 VJ Bonneville Jubilee	'77	YB9-B WA-N	NB9-B WA
750	Trident	'91→'98	YB14L-A2 WA-N	NB14L-A2 WA
765	Street Triple R	'17→'19	YTX9-BS-N	NTX9-BS
765	Street Triple RS	'17→'19	YTX9-BS-N	NTX9-BS
765	Street Triple S	'17→'19	YTX9-BS-N	NTX9-BS
800	Bonneville	'01→'06	YTX12-BS-N	NTX12-BS
800	Bonnevil. America	'02→'07	YTX12-BS-N	NTX12-BS
800	Bonneville T100	'02→'06	YTX12-BS-N	NTX12-BS
800	Speedmaster	'03→'05	YTX12-BS-N	NTX12-BS
855	T309 Speed Trip.	'94→'97	YB14L-A2 WA-N	NB14L-A2 WA
865	America	'07	YT12B-BS-N	NT12B-BS
865	America EFI	'08→'10	YT12B-BS-N	NT12B-BS
865	America EFI	'11→'17	YTX12-BS-N	NTX12-BS
865	America LT EFI	'14→'17	YTX12-BS-N	NTX12-BS
865	Bonneville	'07	YT12B-BS-N	NT12B-BS
865	Bonneville Black	'07→'08	YT12B-BS-N	NT12B-BS
865	Bonneville EFI	'08→'10	YT12B-BS-N	NT12B-BS
865	Bonneville EFI	'11→'16	YTX12-BS-N	NTX12-BS
865	Bonneville EFI Newchurch	'15→'16	YTX12-BS-N	NTX12-BS
865	Bonneville EFI T100	'08→'10	YT12B-BS-N	NT12B-BS
865	Bonneville EFI T100	'11→'15	YTX12-BS-N	NTX12-BS
865	Bonneville EFI T100 Black	'14	YT12B-BS-N	NT12B-BS

BATTERIE / BATTERY

CC	Modello Model	Anno Years	Vecchio Codice Old Code	Nuovo Codice New Code	CC	Modello Model	Anno Years	Vecchio Codice Old Code	Nuovo Codice New Code
865	Bonneville EFI T100 Black	'15	YTX12-BS-N	NTX12-BS	1050	Speed Triple ABS	'07-'13	YTX12-BS-N	NTX12-BS
865	Bonneville EFI T100 Spirit Ed.	'15	YTX12-BS-N	NTX12-BS	1050	Speed Triple ABS	'14-'16	YTX14-BS-N	NTX14-BS
865	Bonneville EFI T100 Steve Mc Queen	'13	YTX12-BS-N	NTX12-BS	1050	Speed Triple R	'12-'16	YTX14-BS-N	NTX14-BS
865	Bonneville EFI T214 Limited Ed.	'15	YTX12-BS-N	NTX12-BS	1050	Speed Triple R 94 ABS	'15-'16	YTX14-BS-N	NTX14-BS
865	Bonneville SE EFI	'09-'13	YTX12-BS-N	NTX12-BS	1050	Speed Tr. R ABS	'12-'17	YTX14-BS-N	NTX14-BS
865	Bonneville SE EFI Steve McQueen	'12	YTX12-BS-N	NTX12-BS	1050	Speed Tr. RS ABS	'18-'20	YTX14-BS-N	NTX14-BS
865	Bonneville T100	'04-'13	YTX12-BS-N	NTX12-BS	1050	Speed Tr. S ABS	'16-'20	YTX14-BS-N	NTX14-BS
865	Scrambler	'06-'07	YT12B-BS-N	NT12B-BS	1050	Speed Tr. T ABS12		YTX12-BS-N	NTX12-BS
865	Scrambler EFI	'08-'10	YT12B-BS-N	NT12B-BS	1050	Speed Tr. T ABS	'13-'14	YTX14-BS-N	NTX14-BS
865	Scrambler EFI	'11-'17	YTX12-BS-N	NTX12-BS	1050	Sprint GT ABS	'10-'16	YTX14-BS-N	NTX14-BS
865	Speedmaster	'05-'07	YT12B-BS-N	NT12B-BS	1050	Sprint I ST	'11-'12	YTX12-BS-N	NTX12-BS
865	Speedmaster EFI	'08-'10	YT12B-BS-N	NT12B-BS	1050	Sprint I ST ABS	'11-'12	YTX12-BS-N	NTX12-BS
865	Speedmaster EFI	'11-'17	YTX12-BS-N	NTX12-BS	1050	Sprint ST	'05-'10	YTX12-BS-N	NTX12-BS
865	Thruyton	'04-'07	YT12B-BS-N	NT12B-BS	1050	Sprint ST ABS	'05-'10	YTX12-BS-N	NTX12-BS
865	Thruyton ACE	'14-'15	YTX12-BS-N	NTX12-BS	1050	Tiger ABS	'07-'12	YTX12-BS-N	NTX12-BS
865	Thruyton EFI	'11-'16	YTX12-BS-N	NTX12-BS	1050	Tiger SE ABS	'10-'13	YTX12-BS-N	NTX12-BS
865	Thruyton EFI	'08-'10	YT12B-BS-N	NT12B-BS	1050	Tiger Sport ABS	'13-'18	YTX14-BS-N	NTX14-BS
885	T509 Speed Triple	'97-'98	YB14L-A2 WA-N	NB14L-A2 WA	1200	Bonneville Bobber	'17-'19	YTX9-BS-N	NTX9-BS
885	T509 Speed Triple	'97-'01	YB14L-A2 WA-N	NB14L-A2 WA	1200	Bonneville Bobber Black	'18-'19	YTX9-BS-N	NTX9-BS
885	T509 Speed Triple	'99-'01	YTX14-BS-N	NTX14-BS	1200	Bonneville Speedmaster ABS	'18	YTX9-BS-N	NTX9-BS
900	Adventurer	'96-'01	YB14L-A2 WA-N	NB14L-A2 WA	1200	Bonneville T120	'16-'19	YTX12-BS-N	NTX12-BS
900	Bonneville T100 ABS	'17-'19	YTX12-BS-N	NTX12-BS	1200	Bonneville T120 Black	'16-'19	YTX12-BS-N	NTX12-BS
900	Bonneville T100 Black ABS	'17-'19	YTX12-BS-N	NTX12-BS	1200	Daytona	'93-'98	YB14L-A2 WA-N	NB14L-A2 WA
900	Daytona	'93-'97	YB14L-A2 WA-N	NB14L-A2 WA	1200	Trophy	'91-'99	YB14L-A2 WA-N	NB14L-A2 WA
900	Daytona Super III	'94-'97	YB14L-A2 WA-N	NB14L-A2 WA	1200	Trophy	'00-'01	YTX14-BS-N	NTX14-BS
900	Legend TT	'99-'01	YB14L-A2 WA-N	NB14L-A2 WA	1200	Truxton	'16-'18	YTX12-BS-N	NTX12-BS
900	Speed Triple	'94-'96	YB14L-A2 WA-N	NB14L-A2 WA	1200	Truxton R	'16-'20	YTX12-BS-N	NTX12-BS
900	Sprint	'93-'98	YB14L-A2 WA-N	NB14L-A2 WA	1200	Truxton RS	'20-'21	YTX12-BS-N	NTX12-BS
900	Sprint Executive	'97-'98	YB14L-A2 WA-N	NB14L-A2 WA					
900	Street Cup	'17-'19	YTX12-BS-N	NTX12-BS					
900	Street Scrambler	'17-'19	YTX12-BS-N	NTX12-BS					
900	Street Twin	'16-'19	YTX12-BS-N	NTX12-BS					
900	Thunderbird	'95-'03	YB14L-A2 WA-N	NB14L-A2 WA					
900	Thunderbird Sport	'98-'04	YB14L-A2 WA-N	NB14L-A2 WA					
900	Tiger	'92-'93	YB14L-A2 WA-N	NB14L-A2 WA					
900	Tiger	'95-'98	YB14L-A2 WA-N	NB14L-A2 WA					
900	Tiger	'99	YTX14-BS-N	NTX14-BS					
900	Tiger EFI	'98	YB14L-A2 WA-N	NB14L-A2 WA					
900	Tiger EFI	'99	YTX14-BS-N	NTX14-BS					
900	Trident	'92-'98	YB14L-A2 WA-N	NB14L-A2 WA					
900	Trident TT	'91	YB14L-A2 WA-N	NB14L-A2 WA					
900	TROPHY	'91-'01	YB14L-A2 WA-N	NB14L-A2 WA					
955	Daytona I	'98-'06	YTX14-BS-N	NTX14-BS					
955	Speed Triple	'02-'04	YTX14-BS-N	NTX14-BS					
955	Sprint RS	'99-'04	YTX14-BS-N	NTX14-BS					
955	Sprint ST	'99-'04	YTX14-BS-N	NTX14-BS					
955	T595 Daytona	'97-'98	YTX14-BS-N	NTX14-BS					
955	Tiger	'99-'04	YTX14-BS-N	NTX14-BS					
955	Tiger I	'04-'06	YTX14-BS-N	NTX14-BS					
1000	Daytona	'91-'92	YB14L-A2 WA-N	NB14L-A2 WA					
1000	Trophy	'92-'92	YB14L-A2 WA-N	NB14L-A2 WA					
1050	Speed Triple	'05-'13	YTX12-BS-N	NTX12-BS					
1050	Speed Triple	'14-'16	YTX14-BS-N	NTX14-BS					
1050	Speed Triple 94 ABS	'15-'16	YTX14-BS-N	NTX14-BS					

YAMAHA									
50	Aerox (NS50F)	'14-'20	YB5L-B WA-N	NB5L-B WA					
50	Aerox (YQ50)	'97-'15	YB4L-B WA-N	NB4L-B WA					
50	Aerox R (NS50)	'13-'17	YB4L-B WA-N	NB4L-B WA					
50	Aerox R (YQ50)	'97-'15	YB4L-B WA-N	NB4L-B WA					
50	Aerox R Naked (NS50N)	'13-'17	YB4L-B WA-N	NB4L-B WA					
50	Axis	'95-'96	YT4L-BS-N	NT4L-BS					
50	Breeze	'94-'95	YB4L-B WA-N	NB4L-B WA					
50	BW'S	'96-'17	YB4L-B WA-N	NB4L-B WA					
50	BW'S Naked	'15-'17	YB4L-B WA-N	NB4L-B WA					
50	BW'S Next Generation	'99-'07	YB4L-B WA-N	NB4L-B WA					
50	BW'S Original	'00-'02	YB4L-B WA-N	NB4L-B WA					
50	BW'S SPY	'97-'98	YB4L-B WA-N	NB4L-B WA					
50	CR-Z	'91-'95	YB4L-B WA-N	NB4L-B WA					
50	DT R	'03-'12	YB4L-B WA-N	NB4L-B WA					
50	DT R SuperM.	'02-'07	YB4L-B WA-N	NB4L-B WA					
50	DT X SuperM.	'08-'12	YB4L-B WA-N	NB4L-B WA					
50	JOG	'88-'92	YB4L-B WA-N	NB4L-B WA					
50	JOG	'00-'08	YT4L-BS-N	NT4L-BS					
50	JOG R	'02-'15	YT4L-BS-N	NT4L-BS					
50	JOG R	'03-'08	YT4L-BS-N	NT4L-BS					
50	JOG R RS	'96-'96	YT4L-BS-N	NT4L-BS					
50	JOG RR	'03-'15	YT4L-BS-N	NT4L-BS					
50	Jog-In	'91-'95	YT4L-BS-N	NT4L-BS					
50	Neo's	'02-'08	YB4L-B WA-N	NB4L-B WA					
50	Neo's 2T	'09-'16	YB4L-B WA-N	NB4L-B WA					
50	Neo's 4T	'09-'20	YB5L-B WA-N	NB5L-B WA					

BATTERIE / BATTERY

CC	Modello Model	Anno Years	Vecchio Codice Old Code	Nuovo Codice New Code	CC	Modello Model	Anno Years	Vecchio Codice Old Code	Nuovo Codice New Code
50	Neo's R	'97→02	YB4L-B WA-N	NB4L-B WA	125	YBR	'00→06	YB5L-B WA-N	NB5L-B WA
50	Slider	'00→05	YB4L-B WA-N	NB4L-B WA	125	YBR	'07→08	YTX7L-BS-N	NTX7L-BS
50	Slider N	'16→16	YB4L-B WA-N	NB4L-B WA	125	YBR E	'06	YB5L-B WA-N	NB5L-B WA
50	TZR	'00→16	YT4L-BS-N	NT4L-BS	125	YBR E	'08	YB5L-B WA-N	NB5L-B WA
50	TZR Thunderkid	'97→00	YT4L-BS-N	NT4L-BS	125	YBR E	'11→13	YB5L-B WA-N	NB5L-B WA
50	WHY	'99→09	YB4L-B WA-N	NB4L-B WA	125	YBR ED	'05→06	YB5L-B WA-N	NB5L-B WA
50	XC X Vino Classic	'08	YTX5L-BS-N	NTX5L-BS	125	YBR ED	'07→14	YTX7L-BS-N	NTX7L-BS
50	XF Giggie / VOX	'07→09	YTX5L-BS-N	NTX5L-BS	125	YBR EGS	'08	YB5L-B WA-N	NB5L-B WA
50	YA	'95	YT4L-BS-N	NT4L-BS	125	YBR EGS	'10→16	YB5L-B WA-N	NB5L-B WA
50	YFZ	'17→18	YTX5L-BS-N	NTX5L-BS	125	YBR SPD Custom	'08→16	YTX7L-BS-N	NTX7L-BS
50	YFZ BW4	'17→20	YTX5L-BS-N	NTX5L-BS	125	YFM R Raptor	'11→13	YTZ7S-BS-N	NTZ7S-BS
50	ZEST	'93→95	YB4L-B WA-N	NB4L-B WA	125	YS	'17→20	YTX5L-BS-N	NTX5L-BS
50	ZR Evolution	'01→02	YT4L-BS-N	NT4L-BS	150	Maxster	'01→03	YB7L-B2 WA-N	NB7L-B2 WA
90	YFM R	'16→20	YTX5L-BS-N	NTX5L-BS	150	N-Max	'15→17	YTZ7S-BS-N	NTZ7S-BS
90	YFM R Raptor	'09→13	YTX5L-BS-N	NTX5L-BS	150	Xenter	'12→16	YT7B-BS-N	NT7B-BS
100	BW'S	'96	YT4L-BS-N	NT4L-BS	155	Tricity (MWS)	'16→19	YTZ7S-BS-N	NTZ7S-BS
100	Neo's	'99→03	YT4L-BS-N	NT4L-BS	200	RD DX	'75→77	YB9-B WA-N	NB9-B WA
125	BW'S	'10→14	YT7B-BS-N	NT7B-BS	200	RD DX	'78	YB9-B WA-N	NB9-B WA
125	DT RE	'04→07	YTZ7S-BS-N	NTZ7S-BS	200	RD DX	'79→80	YB9-B WA-N	NB9-B WA
125	DT X	'05→06	YTZ7S-BS-N	NTZ7S-BS	200	YFM D	'89→90	YTX14-BS-N	NTX14-BS
125	Majesty S	'14	YT7B-BS-N	NT7B-BS	200	YFM N	'85	YTX14-BS-N	NTX14-BS
125	Maxster	'01→03	YB7L-B2 WA-N	NB7L-B2 WA	200	YFS Blaster	'89→06	YTX14-BS-N	NTX14-BS
125	N-Max	'15→20	YTZ7S-BS-N	NTZ7S-BS	200	YTM ELD	'89	YTX14-BS-N	NTX14-BS
125	RD LC	'86→89	YB5L-B WA-N	NB5L-B WA	225	XT	'97→00	YTX7L-BS-N	NTX7L-BS
125	TDR	'89→93	YTX5L-BS-N	NTX5L-BS	225	XT	'01→06	YTZ7S-BS-N	NTZ7S-BS
125	TDR R	'94→03	YTX5L-BS-N	NTX5L-BS	225	XT Serrow	'86→93	YTX7L-BS-N	NTX7L-BS
125	TDR R Lightburner	'93→94	YTX5L-BS-N	NTX5L-BS	225	XT W Serrow	'93→98	YTX7L-BS-N	NTX7L-BS
125	Teo's	'00→03	YB7L-B2 WA-N	NB7L-B2 WA	225	YFM	'86→89	YTX14-BS-N	NTX14-BS
125	Tricity (MW A)	'15→16	YTZ7S-BS-N	NTZ7S-BS	225	YTM DR	'85	YTX14-BS-N	NTX14-BS
125	Tricity (MW)	'14→16	YTZ7S-BS-N	NTZ7S-BS	230	TTR	'05→06	YTX5L-BS-N	NTX5L-BS
125	Tricity (MWS A)	'17→20	YTZ7S-BS-N	NTZ7S-BS	250	CP Maxam	'05→08	YTZ10S-BS-N	NTZ10S-BS
125	Tricity (MWS C)	'17→20	YTZ7S-BS-N	NTZ7S-BS	250	Majesty	'96→03	YT7B-BS-N	NT7B-BS
125	TT-R	'00→05	YT4L-BS-N	NT4L-BS	250	Majesty DX	'98→99	YT7B-BS-N	NT7B-BS
125	TT-R E	'04→09	YT4L-BS-N	NT4L-BS	250	SRV Soulfultwin/ Renaissa	'92→97	YTX7A-BS-N	NTX7A-BS
125	TT-R LW	'00→16	YT4L-BS-N	NT4L-BS	250	TDR	'88→92	YB5L-B WA-N	NB5L-B WA
125	TT-R LWE	'03→20	YT4L-BS-N	NT4L-BS	250	Tricker	'04→07	YTZ7S-BS-N	NTZ7S-BS
125	TW	'02→06	YTZ7S-BS-N	NTZ7S-BS	250	TRX X	'12→13	YTX9-BS-N	NTX9-BS
125	TZR	'87→95	YB5L-B WA-N	NB5L-B WA	250	TT R	'93→04	YT7B-BS-N	NT7B-BS
125	TZR R	'91→93	YB5L-B WA-N	NB5L-B WA	250	TT R USA	'99→06	YT7B-BS-N	NT7B-BS
125	TZR RR	'94→97	YB5L-B WA-N	NB5L-B WA	250	TZR	'87→92	YB5L-B WA-N	NB5L-B WA
125	VITY	'08→13	YTX7A-BS-N	NTX7A-BS	250	TZR R	'91→93	YB5L-B WA-N	NB5L-B WA
125	XC Cygnus X	'04→06	YTX7A-BS-N	NTX7A-BS	250	TZR RS	'92→94	YB5L-B WA-N	NB5L-B WA
125	XC Cygnus XI	'07→13	YT7B-BS-N	NT7B-BS	250	TZR SP	'90	YB5L-B WA-N	NB5L-B WA
125	XC E Vity	'08→13	YTX7A-BS-N	NTX7A-BS	250	TZR SPR	'95	YB5L-B WA-N	NB5L-B WA
125	XC Flame X	'05→06	YTX7A-BS-N	NTX7A-BS	250	WR F	'03→07	YTX5L-BS-N	NTX5L-BS
125	XC Flame X	'07→10	YT7B-BS-N	NT7B-BS	250	WR F	'08→20	YTZ7S-BS-N	NTZ7S-BS
125	X-City	'08→15	YTX9-BS-N	NTX9-BS	250	WR R	'08→15	YTZ7S-BS-N	NTZ7S-BS
125	Xenter	'12→20	YT7B-BS-N	NT7B-BS	250	WR X Supermoto	'08→15	YTZ7S-BS-N	NTZ7S-BS
125	X-Max	'06→13	YTX9-BS-N	NTX9-BS	250	X-City	'07→16	YTX9-BS-N	NTX9-BS
125	X-Max	'14→17	YT9B-BS-N	NT9B-BS	250	X-City ABS	'14→16	YTX9-BS-N	NTX9-BS
125	X-Max - Iron Max ABS	'16→16	YT9B-BS-N	NT9B-BS	250	X-Max	'05→13	YTX9-BS-N	NTX9-BS
125	X-Max ABS	'11→13	YTX9-BS-N	NTX9-BS	250	X-Max	'14→16	YT9B-BS-N	NT9B-BS
125	X-Max ABS	'14→17	YT9B-BS-N	NT9B-BS	250	X-Max	'16	YT9B-BS-N	NT9B-BS
125	X-Max Busin. ABS	'11	YTX9-BS-N	NTX9-BS	250	X-Max Iron Max ABS			
125	X-Max Sport	'11→13	YTX9-BS-N	NTX9-BS	250	X-Max ABS	'11→13	YTX9-BS-N	NTX9-BS
125	X-Max Sport	'14→16	YT9B-BS-N	NT9B-BS	250	X-Max ABS	'14→15	YT9B-BS-N	NT9B-BS
125	XT R	'05→11	YTX7L-BS-N	NTX7L-BS	250	X-Max Sport	'11→12	YTX9-BS-N	NTX9-BS
125	XT X	'05→11	YTX7L-BS-N	NTX7L-BS	250	XT Serow	'05	YTX7L-BS-N	NTX7L-BS
125	XTZ	'03→10	YB5L-B WA-N	NB5L-B WA	250	XT X	'06→08	YTZ7S-BS-N	NTZ7S-BS
125	XVS Dragstar	'00→05	YTZ7S-BS-N	NTZ7S-BS	250	XVS Dragster	'01→03	YTZ7S-BS-N	NTZ7S-BS
125	YB SPD	'08	YTX7L-BS-N	NTX7L-BS	250	YBR	'07→12	YTX7L-BS-N	NTX7L-BS

BATTERIE / BATTERY

CC	Modello Model	Anno Years	Vecchio Codice Old Code	Nuovo Codice New Code	CC	Modello Model	Anno Years	Vecchio Codice Old Code	Nuovo Codice New Code
250	YFM	'90→'91	YTX14-BS-N	NTX14-BS	600	FZ 6 S2 Fazer	'07→'09	YT12B-BS-N	NT12B-BS
250	YFM R Raptor	'08→'13	YTZ7S-BS-N	NTZ7S-BS	600	FZ 6 S2 Faz. ABS	'08→'09	YT12B-BS-N	NT12B-BS
250	YS Fazer	'06→'08	YTX7L-BS-N	NTX7L-BS	600	FZR	'89→'93	YB12AL-A2 WA-N	NB12AL-A2 WA
300	XC Versity	'03→'06	YTX9-BS-N	NTX9-BS	600	FZR R	'94→'95	YTX12-BS-N	NTX12-BS
300	YFM Grizzly	'12→'13	YTX12-BS-N	NTX12-BS	600	FZS fazer	'98→'03	YT12B-BS-N	NT12B-BS
350	RD LCF	'85→'92	YB5L-B WA-N	NB5L-B WA	600	SRX	'85→'93	YB5L-B WA-N	NB5L-B WA
350	RD N	'85	YB5L-B WA-N	NB5L-B WA	600	TT E	'94→'01	YTX9-BS-N	NTX9-BS
350	RD R	'92→'95	YB5L-B WA-N	NB5L-B WA	600	TT K	'93→'96	YTX9-BS-N	NTX9-BS
350	YFM R Raptor	'05→'13	YTZ10S-BS-N	NTZ10S-BS	600	TT RE	'02→'04	YT9B-BS-N	NT9B-BS
400	FZR	'88	YB12AL-A2 WA-N	NB12AL-A2 WA	600	XJ 6 F Diversion	'10→'16	YT12B-BS-N	NT12B-BS
400	FZR Genesis	'86	YB12AL-A2 WA-N	NB12AL-A2 WA	600	XJ 6 F Diversion ABS	'10→'16	YT12B-BS-N	NT12B-BS
400	FZR R	'89	YB12AL-A2 WA-N	NB12AL-A2 WA	600	XJ 6 N Diversion	'09→'16	YT12B-BS-N	NT12B-BS
400	FZR RR	'86	YB12AL-A2 WA-N	NB12AL-A2 WA	600	XJ 6 N Diversion ABS	'09→'16	YT12B-BS-N	NT12B-BS
400	FZR RR	'90→'95	YTX9-BS-N	NTX9-BS	600	XJ 6 S Diversion	'09→'16	YT12B-BS-N	NT12B-BS
400	FZR RRS	'86	YB12AL-A2 WA-N	NB12AL-A2 WA	600	XJ 6 S Diversion ABS	'09→'16	YT12B-BS-N	NT12B-BS
400	FZR RS	'86	YB12AL-A2 WA-N	NB12AL-A2 WA	600	XJ 6 SP Diversion ABS	'13→'13	YT12B-BS-N	NT12B-BS
400	Majesty	'04→'12	YT9B-BS-N	NT9B-BS	600	XJ N Diversion	'91→'03	YTX9-BS-N	NTX9-BS
400	Majesty ABS	'05→'13	YT9B-BS-N	NT9B-BS	600	XJ S Diversion	'92→'03	YTX9-BS-N	NTX9-BS
400	XJR	'93→'99	YTX9-BS-N	NTX9-BS	600	XT	'84→'95	YB5L-B WA-N	NB5L-B WA
400	X-Max	'13→'16	YT9B-BS-N	NT9B-BS	600	XT E	'90→'03	YTX9-BS-N	NTX9-BS
400	X-Max ABS	'14→'20	YT9B-BS-N	NT9B-BS	600	XT Z Tenere	'85	YB5L-B WA-N	NB5L-B WA
400	X-Max Iron Max	'16	YT9B-BS-N	NT9B-BS	600	XT Z Tenere	'86→'95	YB12AL-A2 WA-N	NB12AL-A2 WA
400	YFM FG Grizzly	'07→'08	YTX14-BS-N	NTX14-BS	600	YZF R Thundercat	'96→'03	YTX12-BS-N	NTX12-BS
450	WR F	'03→'20	YTZ7S-BS-N	NTZ7S-BS	600	YZF-R6	'99→'00	YT12B-BS-N	NT12B-BS
450	YFZ	'03→'13	YT7B-BS-N	NT7B-BS	600	YZF-R6	'01→'05	YT9B-BS-N	NT9B-BS
450	YFZ R	'09→'18	YTZ7S-BS-N	NTZ7S-BS	600	YZF-R6	'06	YTZ10S-BS-N	NTZ10S-BS
450	YFZ R	'19→'20	YTZ7S-BS-N	NTZ7S-BS	600	YZF-R6	'17→'20	YTZ7S-BS-N	NTZ7S-BS
450	YZ FX	'16→'20	YTZ7S-BS-N	NTZ7S-BS	650	XS	'75→'81	YB14L-A2 WA-N	NB14L-A2 WA
500	FZR	'89→'93	YB12AL-A2 WA-N	NB12AL-A2 WA	650	XS SE	'79→'81	YB14L-A2 WA-N	NB14L-A2 WA
500	T-Max	'01→'07	YT9B-BS-N	NT9B-BS	650	XVS A Drag Star Classic	'98→'07	YT12B-BS-N	NT12B-BS
500	T-Max	'08→'12	YTZ10S-BS-N	NTZ10S-BS	650	XVS Drag Star	'97→'04	YT12B-BS-N	NT12B-BS
500	T-Max ABS	'08→'12	YTZ10S-BS-N	NTZ10S-BS	660	MT-03	'06→'14	YT9B-BS-N	NT9B-BS
500	XS	'75→'79	YB14L-A2 WA-N	NB14L-A2 WA	660	SZR	'96→'98	YT9B-BS-N	NT9B-BS
500	XT E	'90→'96	YB5L-B WA-N	NB5L-B WA	660	XT R	'04→'16	YT9B-BS-N	NT9B-BS
500	XT T	'88→'89	YB5L-B WA-N	NB5L-B WA	660	XT X Supermoto	'04→'16	YT9B-BS-N	NT9B-BS
500	XT Z	'88→'89	YB5L-B WA-N	NB5L-B WA	660	XT Z Tenere	'08→'16	YT9B-BS-N	NT9B-BS
530	T-Max	'12→'16	YTZ12S-BS-N	NTZ12S-BS	660	XT Z Tenere ABS	'11→'16	YT9B-BS-N	NT9B-BS
530	T-Max ABS	'12→'19	YTZ12S-BS-N	NTZ12S-BS	660	XTZ Tenere	'90→'00	YTX9-BS-N	NTX9-BS
530	T-Max ABS DX	'17→'19	YTZ12S-BS-N	NTZ12S-BS	660	YFM R Raptor	'01→'06	YTX14-BS-N	NTX14-BS
530	T-Max ABS SX	'17→'19	YTZ12S-BS-N	NTZ12S-BS	700	FZX Fazer	'86→'87	YB14L-A2 WA-N	NB14L-A2 WA
530	T-Max ABS SX Sport Edition	'18→'19	YTZ12S-BS-N	NTZ12S-BS	700	MT-07	'14→'16	YTZ10S-BS-N	NTZ10S-BS
530	T-Max Black Max	'12→'14	YTZ12S-BS-N	NTZ12S-BS	700	MT-07 ABS	'14→'20	YTZ10S-BS-N	NTZ10S-BS
530	T-Max Black Max ABS	'12→'14	YTZ12S-BS-N	NTZ12S-BS	700	MT-07 Moto Cage	'15→'17	YTZ10S-BS-N	NTZ10S-BS
530	T-Max Bronze Max	'12→'14	YTZ12S-BS-N	NTZ12S-BS	700	MT-07 Trac. ABS	'16→'19	YTZ10S-BS-N	NTZ10S-BS
530	T-Max Iron Max	'14→'16	YTZ12S-BS-N	NTZ12S-BS	700	MT-07 Trac. ABS	'20	YTZ7S-BS-N	NTZ7S-BS
530	T-Max Iron Max ABS	'14→'16	YTZ12S-BS-N	NTZ12S-BS	700	MT-07 Tracer GT	'19→'20	YTZ10S-BS-N	NTZ10S-BS
530	T-Max Lux Max ABS	'16	YTZ12S-BS-N	NTZ12S-BS	700	XSR	'16→'20	YTZ10S-BS-N	NTZ10S-BS
535	XV S Virago	'95→'03	YB12AL-A2 WA-N	NB12AL-A2 WA	700	XSR X Tribute	'19→'20	YTZ10S-BS-N	NTZ10S-BS
535	XV Virago	'88→'03	YB12AL-A2 WA-N	NB12AL-A2 WA	700	XT Z Tenere	'19→'20	YTZ10S-BS-N	NTZ10S-BS
550	XT	'82→'83	YB5L-B WA-N	NB5L-B WA	700	YFM R Raptor	'05→'20	YT9B-BS-N	NT9B-BS
550	XZ	'82→'84	YB14L-A2 WA-N	NB14L-A2 WA	750	FZ	'85→'91	YB14L-A2 WA-N	NB14L-A2 WA
560	T-Max ABS	'20	YTZ12S-BS-N	NTZ12S-BS	750	FZR Genesis	'87→'89	YB14L-A2 WA-N	NB14L-A2 WA
560	T-Max Tech Max ABS	'20	YTZ12S-BS-N	NTZ12S-BS	750	FZR R OW01	'88→'90	YB14L-A2 WA-N	NB14L-A2 WA
600	FZ 6 N	'04→'07	YT12B-BS-N	NT12B-BS	750	FZX Fazer	'86→'97	YB14L-A2 WA-N	NB14L-A2 WA
600	FZ 6 S Fazer	'04→'07	YT12B-BS-N	NT12B-BS	750	XJ	'82→'84	YB14L-A2 WA-N	NB14L-A2 WA
600	FZ 6 S Fazer ABS	'06→'07	YT12B-BS-N	NT12B-BS	750	XJ R Seca	'81→'83	YB14L-A2 WA-N	NB14L-A2 WA
600	FZ 6 S2	'07→'10	YT12B-BS-N	NT12B-BS					

BATTERIE / BATTERY

CC	Modello Model	Anno Years	Vecchio Codice Old Code	Nuovo Codice New Code	CC	Modello Model	Anno Years	Vecchio Codice Old Code	Nuovo Codice New Code
750	XS	'77→'79	YB14L-A2 WA-N	NB14L-A2 WA	1000	YZF-R1	'15→'20	YTZ7S-BS-N	NTZ7S-BS
750	XS SE	'79→'80	YB14L-A2 WA-N	NB14L-A2 WA	1000	YZF-R1 60th Ann.	'15→'16	YTZ7S-BS-N	NTZ7S-BS
750	XTZ Super Tenere	'89→'00	YB14L-A2 WA-N	NB14L-A2 WA	1000	YZF-R1 SP	'06	YTZ10S-BS-N	NTZ10S-BS
750	XV SE	'81	YB16AL-A2 WA-N	NB16AL-A2 WA	1000	YZF-R1M	'15→'20	YTZ7S-BS-N	NTZ7S-BS
750	XV Virago	'92→'97	YB16AL-A2 WA-N	NB16AL-A2 WA	1000	YZF-R1M 60th Anniversary	'15→'16	YTZ7S-BS-N	NTZ7S-BS
750	YZF R	'93→'98	YTX12-BS-N	NTX12-BS	1100	FJ	'83→'85	YB14L-A2 WA-N	NB14L-A2 WA
750	YZF SP	'93→'99	YTX12-BS-N	NTX12-BS	1200	FJ	'86→'89	YB14L-A2 WA-N	NB14L-A2 WA
750	YZF-R7 OW02	'99→'03	YT9B-BS-N	NT9B-BS	1200	FJ	'90→'95	YTX14-BS-N	NTX14-BS
800	FZ 8 N	'10→'16	YTZ10S-BS-N	NTZ10S-BS	1200	FJ ABS	'91→'95	YTX14-BS-N	NTX14-BS
800	FZ 8 N ABS	'10→'16	YTZ10S-BS-N	NTZ10S-BS	1200	V-Max	'91→'03	YB16AL-A2 WA-N	NB16AL-A2 WA
800	FZ 8 S Fazer	'10→'16	YTZ10S-BS-N	NTZ10S-BS	1200	XJR	'95→'98	YTX14-BS-N	NTX14-BS
800	FZ 8 S Fazer ABS	'10→'16	YTZ10S-BS-N	NTZ10S-BS	1200	XT Z Super Tenere ABS	'10→'20	YTZ12S-BS-N	NTZ12S-BS
850	Niken ABS (MXT)	'18→'20	YTZ10S-BS-N	NTZ10S-BS	1200	XT ZE Sup. Tenere ABS Raid Edition	'18→'20	YTZ12S-BS-N	NTZ12S-BS
850	Niken GT ABS (MXT)	'19→'20	YTZ10S-BS-N	NTZ10S-BS	1300	XJR	'07→'14	YTZ14S-BS-N	NTZ14S-BS
850	TDM	'91→'95	YTX12-BS-N	NTX12-BS	1300	XJR C	'15→'17	YTZ14S-BS-N	NTZ14S-BS
850	TDM	'96→'01	YT12B-BS-N	NT12B-BS	1300	XJR C Racer	'16→'17	YTZ14S-BS-N	NTZ14S-BS
850	TRX	'96→'99	YTX12-BS-N	NTX12-BS	1700	V-Max	'09→'16	YTZ14S-BS-N	NTZ14S-BS
850	XS	'80	YB14L-A2 WA-N	NB14L-A2 WA					
900	MT-09	'13→'16	YTZ10S-BS-N	NTZ10S-BS					
900	MT-09 ABS	'14→'20	YTZ10S-BS-N	NTZ10S-BS					
900	MT-09 SP ABS	'18→'20	YTZ10S-BS-N	NTZ10S-BS					
900	MT-09 Sport Tracker ABS	'14→'17	YTZ10S-BS-N	NTZ10S-BS					
900	MT-09 Street Rally ABS	'14→'17	YTZ10S-BS-N	NTZ10S-BS					
900	MT-09 Trac. ABS	'15→'20	YTZ10S-BS-N	NTZ10S-BS					
900	MT-09 Tracer GT ABS	'18→'20	YTZ10S-BS-N	NTZ10S-BS					
900	TDM	'02→'14	YT12B-BS-N	NT12B-BS					
900	TDM ABS	'05→'13	YT12B-BS-N	NT12B-BS					
900	XJ	'83→'94	YB14L-A2 WA-N	NB14L-A2 WA					
900	XJ F	'83→'94	YB14L-A2 WA-N	NB14L-A2 WA					
900	XJ S Diversion	'95→'03	YTX14-BS-N	NTX14-BS					
900	XSR	'16→'20	YTZ10S-BS-N	NTZ10S-BS					
900	XSR 60th Ann.	'16	YTZ10S-BS-N	NTZ10S-BS					
900	XSR Abarth ABS	'16→'19	YTZ10S-BS-N	NTZ10S-BS					
900	XSR Speedblock	'16→'17	YTZ10S-BS-N	NTZ10S-BS					
950	SCR	'17→'20	YTZ14S-BS-N	NTZ14S-BS					
950	XV	'17→'17	YTZ14S-BS-N	NTZ14S-BS					
950	XV R	'14→'20	YTZ14S-BS-N	NTZ14S-BS					
950	XV Racer	'17→'18	YTZ14S-BS-N	NTZ14S-BS					
950	XVS A Midnight Star	'09→'13	YTZ14S-BS-N	NTZ14S-BS					
950	XVS CR Bolt C-Spec	'15→'16	YTZ14S-BS-N	NTZ14S-BS					
950	XVS CU	'14→'16	YTZ14S-BS-N	NTZ14S-BS					
1000	FZ 1 N	'06→'15	YTZ14S-BS-N	NTZ14S-BS					
1000	FZ 1 N Fazer ABS	'08→'15	YTZ14S-BS-N	NTZ14S-BS					
1000	FZ 1 S Fazer	'06→'15	YTZ14S-BS-N	NTZ14S-BS					
1000	FZ 1 S Fazer ABS	'08→'15	YTZ14S-BS-N	NTZ14S-BS					
1000	FZR EXUP	'89→'90	YB14L-A2 WA-N	NB14L-A2 WA					
1000	FZR EXUP	'91→'97	YTX14-BS-N	NTX14-BS					
1000	FZR Genesis	'87→'88	YB14L-A2 WA-N	NB14L-A2 WA					
1000	GTS	'93→'99	YTX14-BS-N	NTX14-BS					
1000	MT-10	'16→'20	YTZ7S-BS-N	NTZ7S-BS					
1000	MT-10 SP	'17→'20	YTZ7S-BS-N	NTZ7S-BS					
1000	MT-10 Tourer Edition	'17→'20	YTZ7S-BS-N	NTZ7S-BS					
1000	YZF R Thunderace	'96→'01	YTX14-BS-N	NTX14-BS					
1000	YZF-R1	'98→'03	YT12B-BS-N	NT12B-BS					
1000	YZF-R1	'04→'14	YTZ10S-BS-N	NTZ10S-BS					

KIT TUBAZIONI FRENO



Allegri[®]
FLEXIBLE SOLUTIONS
TUBAZIONI RACING

motorquality
TECHNOLOGY FOR SPORT

KIT TUBAZIONI FRENO BRAKE HOSES KIT

I nostri kit tubi sono composti con il sistema Global System. Global System è un sistema molto versatile che permette di comporre il kit a proprio piacimento. I kit identificati da *sono kit con raccordi pressati w.m./ergal ad esaurimento.

COME ORDINARE UN KIT TUBI...

Per ordinare nella maniera idonea, occorre utilizzare il codice della motocicletta ed integrarlo con lettere relative al colore dei tubi e numeri riferiti al materiale dei raccordi. Seguite la tabella sottostante per procedere correttamente.

Our brake hoses kits are made by Global System components. Global System is a very simple and flexible system that allows to compose kits for any kind of application (and not only for two wheels). All kits marked with * are still made with pressed fittings.

HOW TO PLACE AN ORDER...

Here is an example of how to define a kit code: check the application and find the CODE (ex. 6AP100 for the Aprilia RSV1000 98→00), add the hose identification COLOR LETTER and fitting identification TYPE NR.

Colore tubo / Hose color	Codice colore / Color code	Raccordi / Fittings	Codice raccordo / Fittings code
Trasparente/Clear	A	Ottone W.M./White Metal Silver	1
Rosso/Red	B	Ottone Gold/White Metal Gold	2
Blu/Blue	C	Ottone Nero/White Metal Black	3
Carbon Look	D	Ergal Blu/Blue light alloy	4
Nero/Black	E	Ergal Rosso/Red light alloy	5
Verde/Green	F		
Bianco/White	G		

Esempio:

Quindi un kit per Aprilia RSV 1000 98→00 con tubi BLU e raccordi ottone Gold diventerà:
6AP100 + C + 2 = 6AP100C2 questo è il codice che dovete ordinare

Qualora non troviate il kit per la vostra moto contattateci.

Example:

So, the complete code for an Aprilia RSV1000 98→00 hoses kit with Blue hoses and Gold fittings will be:
6AP100 + C + 2 = 6AP100C2

In case you don't find your application, please contact us.

N.B. La scritta Ant./Post. indica che il kit include sia le tubazioni anteriori sia la posteriore.

N.B. F/R means that kit includes Front & Rear hoses and fittings

Codice Code	Descrizione Description	Anno Years	A/P	Ottone W.m./Gold €	Ottone Nero €	Ergal Rosso/Blu €
APRILIA						
6AP104	125 RS Extrema (tubi diretti)	'99→'03	Ant./Post.	75,00	87,00	95,00
6AP105	750 SHIVER (tubi diretti)	'08→'12	Ant./Post.	129,00	145,00	154,00
6AP100	1000 RSV/R (tubi diretti)	'98→'00	Ant./Post.	108,00	124,00	136,00
6AP101	1000 RSV/R (tubi diretti)	'01→'02	Ant./Post.	108,00	125,00	137,00
6AP102	1000 RSV/R (tubi diretti)	'03→'05	Ant./Post.	111,00	128,00	139,00
6AP103	1000 RSV/R (tubi diretti)	'06→'09	Ant./Post.	111,00	128,00	139,00
6AP103	1000 RSV/R Nera(tubi diretti)	'04→'05	Ant./Post.	111,00	128,00	139,00
6AP100	1000 RSV SP (tubi diretti)	'99→'00	Ant./Post.	108,00	124,00	136,00
6AP101	1000 RSV SP (tubi diretti)	'01	Ant./Post.	108,00	125,00	137,00
6AP103	1000 RSV FACTORY (tubi diretti)	'04→	Ant./Post.	111,00	128,00	139,00
6AP106	1000 RSV4 R (tubi diretti)	'09→'12	Ant./Post.	108,00	125,00	137,00
6AP106	1000 RSV4R FACTORY (tubi diretti)	'09→'12	Ant./Post.	108,00	125,00	137,00
6AP106	1000 RSV4R FACTORY APRC (tubi dir.)	'11>	Ant./Post.	108,00	125,00	137,00
6AP107	1000 Tuono V4R (tubi diretti)	'11>	Ant./Post.	110,00	128,00	139,00
BMW						
6BM100	S 1000 RR	10→'14	Ant./Post.	110,00	126,00	136,00
6BM101	S 1000 RR	15→	Ant./Post.	110,00	125,00	135,00
DUCATI						
6DU106	600 MONSTER (tubi dir. monodisco)	94>01	Ant./Post.	78,00	90,00	98,00
6DU101	748 (tubi diretti)	'95→'03	Ant./Post.	112,00	130,00	141,00
6DU101	748 R (tubi diretti)	'00→'02	Ant./Post.	112,00	130,00	141,00
6DU105	749 R (tubi diretti)	'04→'06	Ant./Post.	106,00	124,00	133,00
6DU106	750 MONSTER (tubi dir. monodisco)	'96>'97	Ant./Post.	78,00	90,00	98,00
6DU112	750 MONSTER (tubi diretti bidisco)	'96→	Ant./Post.	112,00	130,00	141,00
6DU110	848 (tubi diretti)	'07→'10	Ant./Post.	107,00	122,00	135,00
6DU107	900 MONSTER (tubi diretti)	'93→'99	Ant./Post.	111,00	129,00	140,00

KIT TUBAZIONI FRENO BRAKE HOSES KIT

Codice Code	Descrizione Description	Anno Years	A/P	Ottone W.m./Gold €	Ottone Nero €	Ergal Rosso/Blu €
6DU100	900 MONSTER I.E. (tubi diretti)	'00→'03	Ant./Post.	112,00	130,00	140,00
6DU109	900 SL (tubi diretti)	'92→'98	Ant./Post.	107,00	124,00	135,00
6DU109	900 SS (tubi diretti)	'90→'98	Ant./Post.	107,00	124,00	135,00
6DU101	916 (tubi diretti)	'94→'97	Ant./Post.	112,00	130,00	141,00
6DU102	916 (tubi diretti)	'98→'01	Ant./Post.	111,00	129,00	140,00
6DU103	996 R (tubi diretti)	'98→'01	Ant./Post.	113,00	131,00	142,00
6DU101	996 S (tubi diretti)	'00→'02	Ant./Post.	112,00	130,00	141,00
6DU104	998 S/R (tubi diretti)	'01→'03	Ant./Post.	111,00	128,00	139,00
6DU105	999 R (tubi diretti)	'04→'06	Ant./Post.	106,00	124,00	133,00
6DU108	1098 /R/S (tubi diretti)	'07→'11	Ant./Post.	104,00	121,00	133,00
6DU113	1100 PANIGALE V4/V4S/ Speciale (t.di)	'18→	Ant./Post.	116,00	133,00	144,00
6DU108	1198 /S (tubi diretti)	'09→'11	Ant./Post.	104,00	121,00	133,00
6DU111	1199 PANIGALE/S (tubi diretti)	'12→	Ant./Post.	112,00	130,00	141,00

GUZZI

6GU0114 *	850 Le Mans II-III		Integrale	90,00		
6GU0215 *	850 T3		Integrale	103,00		
6GU0715 *	850 T3 California		Integrale	106,00		
6GU0314 *	1000 Le Mans IV		Integrale	98,00		
6GU0415 *	1000 California II		Integrale	118,00		
6GU0514 *	1000 GT		Integrale	90,00		
6GU0614 *	1000 California III		Integrale	98,00		

* kit con raccordi pressati in W.M. e tubi trasparenti.

* these kits are with Clear hoses and pressed WhiteMetal fittings.

HONDA

6HO111	CBR 600 F/FS (tubi diretti)	'99→'02	Ant./Post.	103,00	124,00	135,00
6HO111	CBR 600 F4 (tubi diretti)	'01→'06	Ant./Post.	103,00	124,00	135,00
6HO110	CBR 600 RR (tubi diretti)	'03→'04	Ant./Post.	103,00	124,00	135,00
6HO100	CBR 600 RR (tubi diretti)	'05	Ant./Post.	104,00	125,00	136,00
6HO101	CBR 600 RR (tubi diretti)	'06	Ant./Post.	107,00	128,00	139,00
6HO102	CBR 600 RR (tubi diretti)	'07→'12	Ant./Post.	105,00	126,00	136,00
6HO114	CBR 600 RR (tubi diretti)	'13→	Ant./Post.	107,00	127,00	138,00
6HO103	HORNET 600 /S (tubi diretti)	'98→'06	Ant./Post.	109,00	130,00	140,00
6HO104	HORNET 600 (tubi diretti)	'07→'13	Ant./Post.	108,00	127,00	140,00
6HO105	CBR 900 RR (tubi diretti)	'00→'01	Ant./Post.	106,00	127,00	138,00
6HO106	CBR 900 RR (tubi diretti)	'02→'03	Ant./Post.	107,00	128,00	139,00
6HO109	HORNET 900 (tubi diretti)	'02→'07	Ant./Post.	108,00	128,00	139,00
6HO113	CB 1000 R (tubi diretti)	'08→	Ant.	76,00	90,00	97,00
6HO107	CBR 1000 RR (tubi diretti)	'04→'07	Ant./Post.	106,00	127,00	138,00
6HO108	CBR 1000 RR (tubi diretti)	'08→'16	Ant./Post.	105,00	126,00	136,00
6HO115	CBR 1000 RR (tubi diretti)	'17→	Ant./Post.	121,00	144,00	155,00
6HO108	CBR 1000 RR SP (tubi diretti)	'14→	Ant./Post.	105,00	126,00	136,00
6HO112	VTR 1000 SP1/SP2 (tubi diretti)	'01→'05	Ant./Post.	105,00	126,00	136,00

KAWASAKI

6KA114	ER 6F/N (tubi diretti)	'06→'12	Ant./Post.	108,00	129,00	140,00
6KA100	ZX 6R (tubi diretti)	'00→'02	Ant./Post.	106,00	127,00	138,00
6KA101	ZX 6RR (tubi diretti)	'03→'04	Ant./Post.	106,00	127,00	138,00
6KA102	ZX 6R/RR (tubi diretti)	'05→'06	Ant./Post.	106,00	128,00	138,00
6KA103	ZX 6R (tubi diretti)	'07→'08	Ant./Post.	103,00	124,00	135,00
6KA110	ZX 6R (tubi diretti)	'09→'12	Ant./Post.	106,00	127,00	138,00
6KA115	ZX 6R (tubi diretti)	'13→	Ant./Post.	106,00	127,00	137,00
6KA118	Z 650 VERSYS (tubi diretti)	'07→'11	Ant./Post.	111,00	132,00	143,00
6KA109	Z 750 (tubi diretti)	'04→'06	Ant./Post.	106,00	127,00	138,00
6KA109	Z 750 S (tubi diretti)	'05→'06	Ant./Post.	106,00	127,00	138,00
6KA104	Z 750 (tubi diretti)	'07→'12	Ant./Post.	107,00	128,00	139,00
6KA116	Z 800 E (pinze flott. T.D.) (t.diret)	'13→	Ant./Post.	108,00	129,00	140,00
6KA117	Z 800 (pinze fisse. T.D.) (t.diret)	'13→	Ant./Post.	107,00	128,00	139,00

KIT TUBAZIONI FRENO
BRAKE HOSES KIT

Codice Code	Descrizione Description	Anno Years	A/P	Ottone W.m./Gold €	Ottone Nero €	Ergal Rosso/Blu €
6KA111	Z 1000 (tubi diretti)	'03→'06	Ant./Post.	108,00	129,00	140,00
6KA105	Z 1000 (tubi diretti)	'07→'09	Ant./Post.	107,00	127,00	139,00
6KA112	Z 1000 (tubi diretti)	'10→'13	Ant./Post.	111,00	132,00	143,00
6KA106	ZX 10 R (tubi diretti)	'04→'05	Ant./Post.	106,00	127,00	138,00
6KA107	ZX 10 R (tubi diretti)	'06→'07	Ant./Post.	103,00	124,00	135,00
6KA108	ZX 10 R (tubi diretti)	'08→'10	Ant./Post.	106,00	127,00	139,00
6KA113	ZX 10 R (tubi diretti)	'11→'15	Ant./Post.	105,00	126,00	137,00
6KA119	ZX 10 R (tubi diretti)	'16→	Ant./Post.	111,00	130,00	141,00

SUZUKI

6SU106	GSR 400 (tubi diretti)	'06→'11	Ant./Post.	109,00	130,00	141,00
6SU111	GSF 600 Bandit/S (tubi diretti)	'95→'99	Ant./Post.	111,00	131,00	140,00
6SU106	GSR 600 (tubi diretti)	'06→'13	Ant./Post.	109,00	130,00	141,00
6SU118	GSXR 600 (tubi diretti)	'97→'99	Ant./Post.	107,00	126,00	137,00
6SU117	GSXR 600 (tubi diretti)	'00→'03	Ant./Post.	107,00	126,00	137,00
6SU100	GSXR 600 (tubi diretti)	'04→'05	Ant./Post.	107,00	128,00	139,00
6SU101	GSXR 600 (tubi diretti)	'06→'07	Ant./Post.	107,00	128,00	139,00
6SU102	GSXR 600 (tubi diretti)	'08→'10	Ant./Post.	106,00	127,00	138,00
6SU119	GSXR 600 (tubi diretti)	'11→	Ant./Post.	105,00	126,00	136,00
6SU116	650 GLAUDIUS (tubi diretti)	'08→	Ant./Post.	108,00	128,00	139,00
6SU103	DL 650 V-STROM (tubi diretti)	'04→'10	Ant./Post.	111,00	132,00	143,00
6SU108	GSF 650 Bandit/S (tubi diretti)	'05→'14	Ant./Post.	112,00	133,00	144,00
6SU107	SV 650 S (tubi diretti)	'03→'10	Ant./Post.	104,00	125,00	136,00
6SU113	SV 650 (tubi diretti)	'99→'02	Ant./Post.	108,00	127,00	138,00
6SU112	SV 650 (tubi diretti)	'03→'10	Ant./Post.	107,00	128,00	138,00
6SU120	GSR 750 (tubi diretti)	'11→	Ant./Post.	109,00	130,00	140,00
6SU118	GSXR 750 (tubi diretti)	'96→'99	Ant./Post.	107,00	126,00	137,00
6SU117	GSXR 750 (tubi diretti)	'00→'03	Ant./Post.	107,00	126,00	137,00
6SU100	GSXR 750 (tubi diretti)	'04→'05	Ant./Post.	107,00	128,00	139,00
6SU101	GSXR 750 (tubi diretti)	'06→'07	Ant./Post.	107,00	128,00	139,00
6SU102	GSXR 750 (tubi diretti)	'08→'10	Ant./Post.	106,00	127,00	138,00
6SU119	GSXR 750 (tubi diretti)	'11→	Ant./Post.	105,00	126,00	136,00
6SU115	GSXR 1000 (tubi diretti)	'03→'04	Ant./Post.	109,00	129,00	140,00
6SU104	GSXR 1000 (tubi diretti)	'05→'06	Ant./Post.	109,00	129,00	140,00
6SU105	GSXR 1000 (tubi diretti)	'07→'08	Ant./Post.	106,00	127,00	138,00
6SU114	GSXR 1000 (tubi diretti)	'09→'11	Ant./Post.	106,00	127,00	138,00
6SU121	GSXR 1000 (tubi diretti)	'12→'16	Ant./Post.	106,00	126,00	137,00
6SU110	GSXR 1300 Hayabusa (tubi diretti)	'99→'07	Ant./Post.	106,00	127,00	138,00
6SU122	GSXR 1000 (tubi diretti)	'17→	Ant./Post.	116,00	137,00	148,00
6SU122	GSXR 1000 R (tubi diretti)	'17→	Ant./Post.	116,00	137,00	148,00

TRIUMPH

6TR100	SPEED III (tubi diretti)	94>96	Ant./Post.	108,00	129,00	139,00
6TR101	SPEED III (tubi diretti)	97>03	Ant./Post.	113,00	134,00	144,00
6TR102	SPEED Triple 1050 (tubi diretti)	05>07	Ant./Post.	113,00	134,00	145,00
6TR103	DAYTONA 675 (tubi diretti)	09>12	Ant./Post.	103,00	124,00	135,00

YAMAHA

6YA127	R3	'15→	Ant./Post.	70,00	84,00	91,00
6YA119	T-MAX 500	'08→'11	Ant./Post.	149,00	169,00	180,00
6YA121	T-MAX 500	'04→'07	Ant./Post.	163,00	183,00	194,00
6YA123	T-MAX 530	'12→'14	Ant.	111,00	121,00	127,00
6YA110	FAZER 600 (tubi diretti)	'98→'03	Ant./Post.	108,00	127,00	140,00
6YA100	FZ6 - FZ 6N (tubi diretti)	'04→'06	Ant./Post.	108,00	135,00	139,00
6YA111	FZ 6 S2 Naked (tubi diretti)	'07→'12	Ant./Post.	108,00	127,00	140,00
6YA112	FZ 6 S2 Carenata (tubi diretti)	'07→'12	Ant./Post.	108,00	127,00	140,00
6YA117	XJ 6 (tubi diretti)	'09→	Ant./Post.	105,00	125,00	137,00
6YA117	XJ 600 Diversion/ F (tubi diretti)	'09→	Ant./Post.	105,00	125,00	137,00
6YA101	YZF 600 R6 (tubi diretti)	'99→'02	Ant./Post.	104,00	125,00	136,00
6YA102	YZF 600 R6 (tubi diretti)	'03→'04	Ant./Post.	103,00	126,00	137,00
6YA103	YZF 600 R6 (tubi diretti)	'05	Ant./Post.	109,00	130,00	141,00

KIT TUBAZIONI FRENO
BRAKE HOSES KIT

Codice Code	Descrizione Description	Anno Years	A/P	Ottone W.m./Gold €	Ottone Nero €	Ergal Rosso/Blu €
6YA104	YZF 600 R6 (tubi diretti)	'06→'16	Ant./Post.	107,00	128,00	138,00
6YA126	YZF 600 R6 (tubi dir.) (elimare ABS)	'17→	Ant./Post.	111,00	132,00	143,00
6YA115	MT-03 660 (tubi diretti)	'06→'12	Ant./Post.	115,00	134,00	146,00
6YA120	FZ8 N - FZ 8S (tubi diretti)	'10→	Ant./Post.	110,00	129,00	141,00
6YA124	MT-09 850 (tubi diretti)	'13→	Ant./Post.	113,00	134,00	145,00
6YA116	TDM 900 (tubi diretti)	'02→'13	Ant./Post.	112,00	132,00	144,00
6YA118	FAZER 1000 GT (tubi diretti)	'09→	Ant./Post.	111,00	130,00	142,00
6YA105	FZ1 FAZER/NAKED (tubi diretti)	'06→	Ant./Post.	109,00	130,00	140,00
6YA113	FZ1 FAZER (tubi diretti)	'01→'05	Ant./Post.	108,00	129,00	140,00
6YA106	YZF 1000 R1 (tubi diretti)	'98→'01	Ant./Post.	106,00	127,00	138,00
6YA107	YZF 1000 R1 (tubi diretti)	'02→'03	Ant./Post.	105,00	126,00	136,00
6YA108	YZF 1000 R1 (tubi diretti)	'04→'06	Ant./Post.	106,00	127,00	138,00
6YA109	YZF 1000 R1 (tubi diretti)	'07→'08	Ant./Post.	103,00	124,00	135,00
6YA114	YZF 1000 R1 (tubi diretti)	'09→'11	Ant./Post.	103,00	124,00	134,00
6YA122	YZF 1000 R1 (tubi diretti)	'12→'14	Ant./Post.	102,00	123,00	134,00
6YA125	YZF 1000 R1 (tubi diretti)	'15→	Ant./Post.	111,00	132,00	143,00

TUBAZIONI GLOBAL SYSTEM

GLOBAL SYSTEM



 FLEXIBLE SOLUTIONS
Allegri[®]
TUBAZIONI RACING

 motorquality
TECHNOLOGY FOR SPORT

GLOBAL SYSTEMS®

Occhio con Canalina di tenuta/
Seal Channel with Eyelet

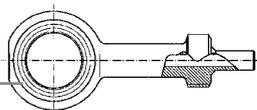

Il più nuovo, affidabile e semplice sistema per montare tubi in treccia metallica. I tubi sono disponibili in varie lunghezze ed è già pressata la ghiera. Voi dovete solo scegliere la lunghezza del tubo, il tipo di raccordo e avviare il tutto. In un attimo il vostro tubo è pronto per essere montato. L'esclusivo sistema di tenuta, omologato DOT, garantirà la massima affidabilità. Veramente un gioco da ragazzi. I raccordi sono identici a quelli usati dal sistema B.H.® e quindi evitano un doppio magazzino. Sono disponibili tubi Global System® anche per moto da fuoristrada con guaina rigida già inserita.

Questo nuovo sistema consente di usufruire delle medesime garanzie di qualità delle grandi produzioni di serie, anche per ordini di piccola entità in quanto il processo produttivo sfrutta gli stessi macchinari ed è sottoposto agli identici standard di controllo delle produzioni destinate ai più prestigiosi costruttori di auto e moto.

Assorbimento min. garantito a 70 bar: 0,230 cc per mt lineare.
Assorbimento min. garantito a 105 bar: 0,290 cc per mt lineare.
Scoppio minimo: 900 bar.
Raggio min. di curvatura: 20 mm.
Strappo dei raccordi alla prova di trazione: 230 Kg.
Temp. max interna: +240°C.
Temp. min. interna: -50°C.
Peso mt. lineare: gr 66.
Dimensioni: 3x7 mm.

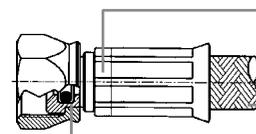

Sistema di pressatura brevettato/
Patented locking System

Tubo B.H. (PTFE + Treccia Inox)
omologato DOT SAE J 1401/
B.H.® Hose (PTFE + Braided Stainless)
Conforming to DOT SAE J 1401

Connessione a doppia tenuta brevettata/
Connection with patented double seal



This is the newest, easiest and safest system to fit stainless-steel embroidered brake-lines. The lines are available with different lengths and have a connection pressed on them. You have only to choose the length of the brake-line, take the needed fittings and screw them on. In a wink your brake-line is ready to fit. The exclusive seal system, DOT approved, grants the highest safety. It is child's play. The fittings are the same used by B.H.® system and in this way the stock is reduced. Global System® brake-lines for cross are also available: they are provided with a rigid sheathing.

Con un minimo investimento ed un ridotto stock si può creare un magazzino che soddisfi tutte le esigenze della clientela, anche le più particolari. Le soluzioni tecniche più ardite troveranno la giusta risposta ad un giusto prezzo. La possibilità di fornire un tubo già assemblato e pertanto con tutte le caratteristiche di sicurezza soddisfatte (collaudo, responsabilità e omologazione), rendono il Global System la soluzione vincente.

È noto che i tradizionali tubi in gomma sono soggetti a degrado con l'invecchiamento. Il nostro tubo in PTFE trecciato inox non subisce alcuna caduta prestazionale con il passare degli anni, in quanto le caratteristiche chimico-fisiche dei materiali che lo compongono ne garantiscono una durata illimitata.

Affidabilità/Reliability



This new system guarantees the same quality standard of mass production also for small orders. The production process runs on the same machinery and conforms to the standards in use by the most prestigious car and motorbike manufacturers.

Le Prestazioni/Performance



Min. guaranteed absorption 70 bar: 0,230 cc per linear metre.
Min. guaranteed absorption 105 bar: 0,290 cc per linear metre.
Min. burst pressure: 900 bar.
Min. bending radius: 20 mm.
Traction resistance of fittings: 230 Kg.
Max. internal Temp.: +240°C.
Min. internal Temp.: -50°C.
Weight per metre: gr. 66.
Dimensions: 3x7 mm.

La Versatilità/Versatility



You need a min. investment to create a stock that meets even the most demanding customer requirements. The most daring technical request will find the right answer at the right price. You will be able to supply a ready assembled brake hose with all safety requirements (testing, responsibilities and certification). This makes the Global System the winning solution.

La Durata/Durability



It is well known that traditional rubber hoses are subject to wear over time. Our hose in braided stainless steel PTFE doesn't deteriorate over the years, the physical and chemical material specifications guarantee unlimited use.

Istruzioni di Montaggio

1- Bloccare il raccordo in morsa facendo attenzione a non danneggiare i piani degli occhielli (utilizzare delle ganasce morbide).
2- Applicare sulla filettatura del raccordo del frenaflessi (tipo LOCTITE 243), avendo cura che lo stesso non vada a contatto con l'anello di tenuta presente all'interno della ghiera posta all'estremità del tubo.
3- Avvitare la ghiera sul raccordo, applicando una coppia di serraggio di 10 Nm (1 Kgm).

N.B.: Per i raccordi in lega leggera questa deve essere ridotta a 8 Nm (0,8 Kgm).

4- In caso di smontaggio del raccordo, pulire perfettamente la filettatura ed assicurarsi che l'anello di tenuta della ghiera sia integro. In caso contrario sostituirlo solo con uno di ricambio (Cod. GS3694). Non utilizzare anelli in NBR in quanto non compatibili con il fluido freni.

Assembly Instructions

1- Clamp the fitting in the vice being careful not to damage the banjo surface (use soft jaws).
2- On the fitting thread, apply some LOCTITE 243 in a way that it does not get in touch with the seal ring inside the ring nut at the end of the hose.
3- Screw the ring nut on the fitting applying a 10 Nm (1Kgm) tightening torque.
N.B.: For light alloy fittings, the tightening torque has to be reduced to 8 Nm (0,8Kgm).

4- In case of fitting disassembly, clean the thread thoroughly and check the integrity of the seal ring. If necessary, replace with an original spare part only (Code GS3694). Do not use NBR seal ring as they are not compatible with the brake fluid.

TUBI FRENO PER RACCORDI GLOBAL SYSTEM® HOSES FOR GLOBAL SYSTEM® FITTING.



Tubo B.H.® con rivestimento
Trasparente, Blu, Rosso, Nero,
Carbon-Look, Verde, Bianco
e ghiera White-Metal.

B.H.® hose with cover:
Transparent, Blue, Red, Black,
Carbon-Look, Green, White and
White-Metal nuts.

Code	Lenght	€
------	--------	---

TUBI BLU / BLUE HOSES

4GS0100B	mm 100	18,00
4GS0125B	mm 125	18,30
4GS0150B	mm 150	18,65
4GS0175B	mm 175	18,90
4GS0200B	mm 200	19,20
4GS0225B	mm 225	19,50
4GS0250B	mm 250	19,85
4GS0275B	mm 275	20,15
4GS0300B	mm 300	20,50
4GS0325B	mm 325	20,80
4GS0350B	mm 350	21,05
4GS0375B	mm 375	21,35
4GS0400B	mm 400	21,70
4GS0425B	mm 425	21,95
4GS0450B	mm 450	22,30
4GS0475B	mm 475	22,60
4GS0500B	mm 500	22,90
4GS0525B	mm 525	23,20
4GS0550B	mm 550	23,50
4GS0575B	mm 575	23,80
4GS0600B	mm 600	24,10
4GS0625B	mm 625	24,40
4GS0650B	mm 650	24,70
4GS0675B	mm 675	25,00
4GS0700B	mm 700	25,30
4GS0725B	mm 725	25,60
4GS0750B	mm 750	25,95
4GS0800B	mm 800	26,50
4GS0850B	mm 850	27,15
4GS0900B	mm 900	27,80
4GS0950B	mm 950	28,40
4GS1000B	mm 1000	29,00
4GS1200B	mm 1200	31,40

TUBI TRASPARENTI / TRANSPARENT HOSES

4GS0075T	mm 75	25,95
4GS0100T	mm 100	18,00
4GS0125T	mm 125	18,30
4GS0150T	mm 150	18,65
4GS0175T	mm 175	18,90
4GS0200T	mm 200	19,20
4GS0225T	mm 225	19,50
4GS0250T	mm 250	19,85
4GS0275T	mm 275	20,15
4GS0300T	mm 300	20,50
4GS0325T	mm 325	20,80
4GS0350T	mm 350	21,05
4GS0375T	mm 375	21,35
4GS0400T	mm 400	21,70
4GS0425T	mm 425	21,95
4GS0450T	mm 450	22,30
4GS0475T	mm 475	22,60
4GS0500T	mm 500	22,90
4GS0525T	mm 525	23,20

Code	Lenght	€
------	--------	---

4GS0550T	mm 550	23,50
4GS0575T	mm 575	23,80
4GS0600T	mm 600	24,10
4GS0625T	mm 625	24,40
4GS0650T	mm 650	24,70
4GS0675T	mm 675	25,00
4GS0700T	mm 700	25,30
4GS0725T	mm 725	25,60
4GS0750T	mm 750	25,95
4GS0775T	mm 775	26,20
4GS0800T	mm 800	26,50
4GS0850T	mm 850	27,15
4GS0900T	mm 900	27,80
4GS0950T	mm 950	28,40
4GS1000T	mm 1000	29,00
4GS1050T	mm 1050	29,60
4GS1150T	mm 1150	30,80
4GS1200T	mm 1200	31,40
4GS1200TX	mm 1200 guaina rigida	46,00
4GS1250TX	mm 1250 guaina rigida	46,50
4GS1275TX	mm 1275 guaina rigida	47,00
4GS1300T	mm 1300	32,70
4GS1300TX	mm 1300 guaina rigida	47,50
4GS1350TX	mm 1350 guaina rigida	48,00
4GS1375T	mm 1375	33,55
4GS1400T	mm 1400	33,80
4GS1450TX	mm 1450 guaina rigida	49,50
4GS1975T	mm 1975	40,85

TUBI CARBON-LOOK / CARBON-LOOK HOSES

4GS0200C	mm 200	19,20
4GS0250C	mm 250	19,85
4GS0300C	mm 300	20,50
4GS0350C	mm 350	21,05
4GS0400C	mm 400	21,70
4GS0425C	mm 425	21,95
4GS0450C	mm 450	22,30
4GS0475C	mm 475	22,60
4GS0500C	mm 500	22,90
4GS0525C	mm 525	23,20
4GS0550C	mm 550	23,50
4GS0575C	mm 575	23,80
4GS0600C	mm 600	24,10
4GS0625C	mm 625	24,40
4GS0650C	mm 650	24,70
4GS0675C	mm 675	25,00
4GS0700C	mm 700	25,30
4GS0725C	mm 725	25,60
4GS0750C	mm 750	25,95
4GS0800C	mm 800	26,50
4GS0850C	mm 850	27,15
4GS0900C	mm 900	27,80
4GS1000C	mm 1000	29,00



TUBI FRENO PER RACCORDI GLOBAL SYSTEM® HOSES FOR GLOBAL SYSTEM® FITTING.

Code	Lenght	€	Code	Lenght	€
TUBI ROSSI / RED HOSES			TUBI VERDI / GREEN HOSES		
4GS0200R	mm 200	19,20	4GS0350V	mm 350	21,05
4GS0250R	mm 250	19,85	4GS0400V	mm 400	21,70
4GS0300R	mm 300	20,50	4GS0450V	mm 450	22,30
4GS0350R	mm 350	21,05	4GS0500V	mm 500	22,90
4GS0400R	mm 400	21,70	4GS0550V	mm 550	23,50
4GS0425R	mm 425	21,95	4GS0600V	mm 600	24,10
4GS0450R	mm 450	22,30	4GS0650V	mm 650	24,70
4GS0475R	mm 475	22,60	4GS0700V	mm 700	25,30
4GS0500R	mm 500	22,90	4GS0750V	mm 750	25,95
4GS0525R	mm 525	23,20	4GS0800V	mm 800	26,50
4GS0550R	mm 550	23,50	4GS0850V	mm 850	27,15
4GS0575R	mm 575	23,80	4GS0900V	mm 900	27,80
4GS0600R	mm 600	24,10	TUBI BIANCHI / WHITE HOSES		
4GS0625R	mm 625	24,40	4GS0300W	mm 300	20,50
4GS0650R	mm 650	24,70	4GS0350W	mm 350	21,05
4GS0675R	mm 675	25,00	4GS0400W	mm 400	21,70
4GS0700R	mm 700	25,30	4GS0450W	mm 450	22,30
4GS0725R	mm 725	25,60	4GS0500W	mm 500	22,90
4GS0750R	mm 750	25,95	4GS0550W	mm 550	23,50
4GS0800R	mm 800	26,50	4GS0600W	mm 600	24,10
4GS0850R	mm 850	27,15	4GS0625W	mm 625	24,40
4GS0900R	mm 900	27,80	4GS0650W	mm 650	24,70
4GS0950R	mm 950	28,40	4GS0700W	mm 700	25,30
4GS1000R	mm 1000	29,00	4GS0725W	mm 725	25,60
TUBI NERI / BLACK HOSES			4GS0750W	mm 750	25,95
4GS0200N	mm 200	19,20	4GS0800W	mm 800	26,50
4GS0250N	mm 250	19,85	4GS0850W	mm 850	27,15
4GS0275N	mm 275	20,15	4GS0900W	mm 900	27,80
4GS0300N	mm 300	20,50	4GS0950W	mm 950	28,40
4GS0350N	mm 350	21,05	4GS1000W	mm 1000	29,00
4GS0375N	mm 375	21,35			
4GS0400N	mm 400	21,70			
4GS0425N	mm 425	21,95			
4GS0450N	mm 450	22,30			
4GS0475N	mm 475	22,60			
4GS0500N	mm 500	22,90			
4GS0550N	mm 550	23,50			
4GS0600N	mm 600	24,10			
4GS0625N	mm 625	24,40			
4GS0650N	mm 650	24,70			
4GS0675N	mm 675	25,00			
4GS0700N	mm 700	25,30			
4GS0725N	mm 725	25,60			
4GS0750N	mm 750	25,95			
4GS0775N	mm 775	26,20			
4GS0800N	mm 800	26,50			
4GS0850N	mm 850	27,15			
4GS0900N	mm 900	27,80			
4GS0950N	mm 950	28,40			
4GS1000N	mm 1000	29,00			
4GS1050N	mm 1050	29,60			
4GS1100N	mm 1100	30,20			
4GS1150N	mm 1150	30,80			
4GS1200N	mm 1200	31,40			
4GS1250N	mm 1250	32,00			
4GS1975N	mm 1975	40,85			

RACCORDI GLOBAL SYSTEM / GLOBAL SYSTEM FITTINGS

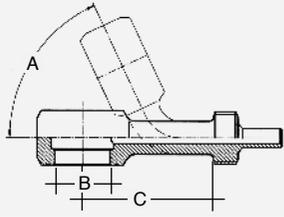

Description	A	B	C	White Metal		White Metal		White Metal		Light Alloy		Light Alloy	
				Silver	€	Gold	€	Nero	€	Blu	€	Rosso	€
Occhiello Dritto/ Straight Banjo	0°	10,1	24	06GS0326	4,30	06GS4740	4,30	06GS5393	6,90	06GS0290	8,65	06GS5022	8,65
Occhiello Dritto Straight Banjo	0°	11,1	24	06GS0264	4,70	06GS4766	4,90	06GS5394	7,85				
Occhiello 25°/ 25° Banjo	25°	10,1	23	06GS0350	5,00	06GS4768	5,00	06GS5396	7,60	06GS0246	9,50	06GS5024	9,50
Occhiello 45°/ 45° Banjo	45°	10,1	20	06GS0314	5,00	06GS4770	5,00	06GS5397	7,60	06GS0247	9,30	06GS5031	9,30
Occhiello 45°/ 45° Banjo	45°	11,1	20	06GS3723	5,40	06GS4776	5,40	06GS5398	8,10				
Occhiello 60°/ 60° Banjo	60°	10,1	18	06GS0339	5,10	06GS4772	5,10	06GS5399	7,70	06GS0245	9,60	06GS5033	9,60
Occhiello 90°/ 90° Banjo	90°	10,1	11	06GS0325	5,10	06GS4774	5,10	06GS5400	7,70	06GS0248	9,30	06GS5035	9,30
Occhiello 90°/ 90° Banjo	90°	11,1	11	06GS3724	5,40	06GS4778	5,40	06GS5401	7,85				

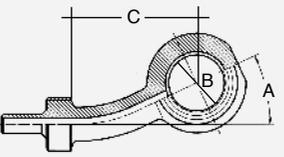

Description	A	B	C	White Metal		White Metal		White Metal		Light Alloy		Light Alloy	
				Silver	€	Gold	€	Nero	€	Blu	€	Rosso	€
Occhiello Laterale 25°/ 25° Side Banjo	25°	10,1	23	06GS0773	5,10	06GS4780	5,10	06GS5404	7,70	06GS0416	9,60	06GS5114	9,60

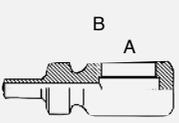

Description	A	B	White Metal		White Metal		White Metal		Light Alloy		Light Alloy	
			Silver	€	Gold	€	Nero	€	Blu	€	Rosso	€
Occhiello Compatto/ Short Banjo	10,1	11	06GS0128	4,90	06GS4760	4,90	06GS5402	7,50	06GS0073	9,10	06GS5112	9,10

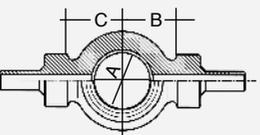

Description	A	B	C	White Metal		White Metal		White Metal		Light Alloy		Light Alloy	
				Silver	€	Gold	€	Nero	€	Blu	€	Rosso	€
Occhiello doppio Comp./ Straight Twin Banjo	10,1	10	10	06GS0078	12,00	06GS4783	16,10	06GS5405	14,60	06GS0071	15,80	06GS5109	15,80

RACCORDI GLOBAL SYSTEM / GLOBAL SYSTEM FITTINGS

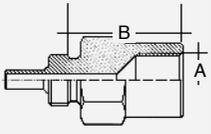
				White Metal	€	White Metal	€	White Metal	€	Light Alloy	€	Light Alloy	€
Description	A	B	C	Silver		Gold		Nero		Blu		Rosso	
Femmina Fissa Sede Svasata/ Fixed Female Concave Seat	M10x1		22	06GS3713	5,40								
	M10x1.25		22	06GS3716	5,40								

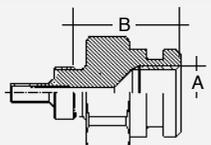
				White Metal	€	White Metal	€	White Metal	€	Light Alloy	€	Light Alloy	€
Description	A	B		Silver		Gold		Nero		Blu		Rosso	
Femmina Fissa con Gola	M10x1		20	06GS0333	5,40								
Sede Svasata/ Fixed Female Concave Seat	M10x1.25		20	06GS3717	5,40								
(clip fixing)	3/8"x 24 UNF		20	06GS3712	5,40								

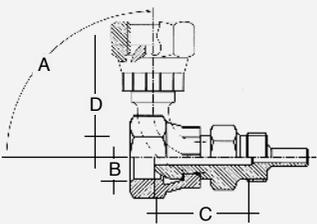
					White Metal	€	White Metal	€	White Metal	€	Light Alloy	€	Light Alloy	€
Description	A	B	C	D	Silver		Gold		Nero		Blu		Rosso	
Femmina Girevole/ Swivel Female	0°	1/8" GAS	18	0	06GS3706	7,40								
Femmina Girevole 45°/ 45° Swivel Female	45°	1/8" GAS	24	11	06GS3708	8,80								
Femmina Girevole 90°/ 90° Swivel Female	90°	1/8" GAS	19	22	06GS3710	8,80								

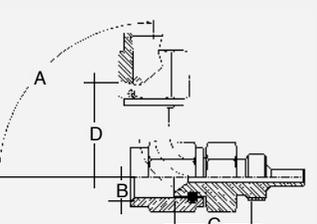
					White Metal	€	White Metal	€	White Metal	€	Light Alloy	€	Light Alloy	€
Description	A	B	C	D	Silver		Gold		Nero		Blu		Rosso	
Femmina Girevole/ Swivel Female	0°	3/8"x24 UNF	13	0	06GS3707	10,35			06GS5426	7,90				
Femmina Girevole 45°/ 45° Swivel Female	45°	3/8"x24 UNF	27	10	06GS3709	13,10								
Femmina Girevole 90°/ 90° Swivel Female	90°	3/8"x24 UNF	20	22	06GS3711	13,10								

Per ottenere la sede da svasata ad ogiva, ordinare anche l'adattatore Cod. 06707070 / For convex seat order adapter Code 06707070

RACCORDI GLOBAL SYSTEM / GLOBAL SYSTEM FITTINGS

				White Metal	€	White Metal	€	White Metal	€	Light Alloy	€	Light Alloy	€
Description	A	B	C D	Silver		Gold		Nero		Blu		Rosso	
Maschio Girevole/ Swivel Male	0°	M10x1	29 0	06GS3700	8,80					06GS3750	10,80		
	0°	M10x1,25	29 0	06GS3701	8,80					06GS3751	10,80		
Maschio Girevole 45°/ 45° Swivel Male	45°	M10x1	39 20	06GS3702	11,20					06GS3752	13,65		
	45°	M10x1,25	39 20	06GS3703	11,20					06GS3753	13,65		
Maschio Girevole 90°/ 90° Swivel Male	90°	M10x1	21 30	06GS3704	11,20					06GS3754	13,65		
	90°	M10x1,25	21 30	06GS3705	11,20					06GS3755	13,65		

				White Metal	€	White Metal	€	White Metal	€	Light Alloy	€	Light Alloy	€
Description	A	B	Es.	Silver		Gold		Nero		Blu		Rosso	
Bullone Forato/ Banjo Bolt	M10x1	19	14	06222847	2,60	06222850	3,15	06GS5522	4,30	06222862	4,70	06222882	4,70
	M10x1,25	19	14	06222848	2,20	06222851	3,15	06GS5523	4,30	06222863	4,85	06222883	4,85
	3/8x24			06222846	1,70								
	7/16x24			06220716	5,50								
	M12x1			06222849	9,40								

				White Metal	€	White Metal	€	White Metal	€	Light Alloy	€	Light Alloy	€
Description	A	B	Es.	Silver		Gold		Nero		Blu		Rosso	
Bullone Forato Doppio/ Double Milled Banjo Bolt	M10x1	30	14	06222827	2,70	06222852	3,60	06GS5526	4,80	06222860	4,70	06222880	4,70
	M10x1,25	30	14	06222828	2,40	06222853	3,60	06GS5527	4,80	06222861	5,60	06222881	5,60
	3/8x24			06222826	2,20								

				White Metal	€	White Metal	€	White Metal	€	Light Alloy	€	Light Alloy	€
Description	A	B	Es.	Silver		Gold		Nero		Blu		Rosso	
Bullone Testa Fresata/ Milled Banjo Bolt	M10x1	21	12/14	06GS5753	6,90								
	M10x1,25	21	12/14	06GS2393	6,90								

RACCORDI GLOBAL SYSTEM / GLOBAL SYSTEM FITTINGS

Description	A	B	Es.	White Metal		White Metal		White Metal		Light Alloy		Light Alloy	
				Silver	Gold	Nero	Blu	Rosso					
Bullone Doppio Testa Fresata/ Double Milled Banjo Bolt	M10x1	32,5	12/14	06GS2362	8,25	06GS2363	9,60						

Description	A	B	C	Es.	White Metal		White Metal		White Metal		Light Alloy		Light Alloy	
					Silver	Gold	Nero	Blu	Rosso					
Bullone Forato per Spurgo/ Milled Banjo Bolt for Bleed	M10x1	M6	21	12	06GS2373	7,60	06GS2371	8,25	06GS2392	7,20	06GS2914	9,20		

Description	A	B	C	Es.	White Metal		White Metal		White Metal		Light Alloy		Light Alloy	
					Silver	Gold	Nero	Blu	Rosso					
Bullone Forato Doppio per Spurgo/ Double Milled Banjo Bolt for Bleed	M10x1	M6	32,5	12	06GS2364	9,60	06GS2368	9,90	06GS2365	9,60	06GS2369	9,90		

Description	A	B	C	White Metal		White Metal		White Metal		Light Alloy		Light Alloy	
				Silver	Gold	Nero	Blu	Rosso					
Tre Vie/ Three Hose Fittings	7	7	7	06GS4300	17,50	06GS4852	17,50	06GS5432	20,10	06GS0692	23,30	06GS5106	23,30

Description	A	B	C	White Metal		White Metal		White Metal		Light Alloy		Light Alloy	
				Silver	Gold	Nero	Blu	Rosso					
Tre Vie/ Three Hose Fittings	7	7	7	06GS6738	31,40								

RACCORDI GLOBAL SYSTEM / GLOBAL SYSTEM FITTINGS

			White Metal	€	White Metal	€	White Metal	€	Light Alloy	€	Light Alloy	€
Description	A	B	Silver		Gold		Nero		Blu		Rosso	
Maschio Fisso	M10x1	20	06GS3714	5,40								
Sede Svasata/ Fixed Male Concave Seat	M10x1,25	20	06GS3715	5,40								
	3/8"x24 UNF	20	06GS3721	7,40								

					White Metal	€	White Metal	€	White Metal	€	Light Alloy	€	Light Alloy	€
Description	A	B	C	Es.	Silver		Gold		Nero		Blu		Rosso	
Vite spurgo/ Bleed screw	M6	5	21,7	7	06GS2360	5,90					06GS2361	6,90		
	M10x1	7	29	11							06212810	6,05		

				White Metal	€	White Metal	€	White Metal	€	Light Alloy	€	Light Alloy	€
Description	Color	A	B	Silver		Gold		Nero		Blu		Rosso	
Cappuccio	Nero/Black	7,50	14	06GS3697	0,70								
Plastica per Vite Spurgo/ Plastic Cup for Bleed Screw	Rosso/Red	7,50	14										
	Blu/Blue	7,50	14										

			White Metal	€	White Metal	€	White Metal	€	Light Alloy	€	Light Alloy	€
Description	A	B	Silver		Gold		Nero		Blu		Rosso	
Maschio Fisso	M10x1	27	06GS3718	3,90								
Passaparete Sede Svasata/ Bulkhead Fixed Male Concave Seat	3/8"x24 UNF	27	06GS3719	4,20								
	M10X1,25	27										

			White Metal	€	White Metal	€	White Metal	€	Light Alloy	€	Light Alloy	€
Description	A	B	Silver		Gold		Nero		Blu		Rosso	
Due Vie/ Two ways	7	7							06GS1169	28,00		

RACCORDI GLOBAL SYSTEM / GLOBAL SYSTEM FITTINGS

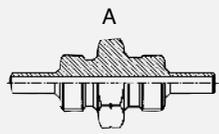
		White Metal	€	White Metal	€	White Metal	€	Light Alloy	€	Light Alloy	€
Description	A	Silver		Gold		Nero		Blu		Rosso	
Niplo Congiunzione/ Junction Nipple	10	06GS3725	3,40								

		White Metal	€	White Metal	€	White Metal	€	Light Alloy	€	Light Alloy	€
Description		Silver		Gold		Nero		Blu		Rosso	
Ghiera + Olivetta/ Socket + Olive (Kit 5 Pz.)		06606060	11,40	06909090	11,40	06303030	22,85	06808080	15,00		

ADATTATORI / ADAPTERS

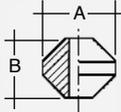
			White Metal	€	White Metal	€	White Metal	€	Light Alloy	€	Light Alloy	€
Description	A	B	Silver		Gold		Nero		Blu		Rosso	
Adattatore Bicono/ Biconical Adapter	8,5	6	06707070	0,80								

ACCESSORI / ACCESSORIES

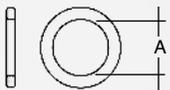
		Alluminium	€	Rame / Copper	€
Description	A				
Rondella/Washer	10	06219614	0,10	06219613	0,10
	11	06219615	0,27		

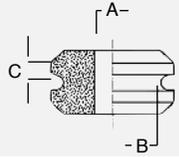
				Alluminium	€
Description	A	B	C		
Gommino Passante/ Raftar End	7	18	4	06GS1121	1,50
	7	15	4	06GS1453	1,45
	10	13	3		

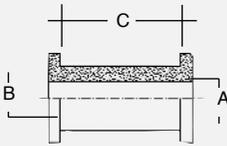
				Alluminium	€
Description	A	B	C		
Gommino Flangiato/ Gom Elastic	7	12	16	06GS0206	0,90
	7	14	20	06GS0182	0,65

ACCESSORI / ACCESSORIES

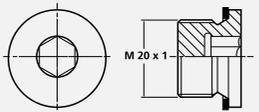
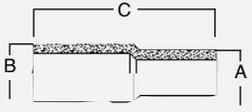
					
Description			Alluminium		€
Tappo Maschio/ Male Plug			Hy-7260		7,20
					
Description	A	B	C	Alluminium	€
Gommino Riduzione/ Reduced Coupling	6,5	10	48	06GS0083	2,05
					
Description				Alluminium	€
Cappucci Gomma Termoretraibili/ Gom Elastic Sleeve Heat-Shrinkable				06GS6054	1,10
					
Description	ØI	ØE			€
Tubo per Fluido/ Brake Fluid Hose	6,5	10,5	6505		1,00 al decimetro
Description			Code		€
O-RING per tubi G.S.			06GS3694		1,10
Gommino anello fermatubo			06GS2515		1,05
Anello fermatubo			06GS2514		1,40
Fascetta fermatubo			0542815		3,50
Molletta per tubo 6505			4285		0,30
					
Description			Code		€
Kit adattatore universale pompa radiale			06102020		17,10
					
Description			Code		€
Kit adattatore universale 25° pompa radiale			06102025		18,40

INNESTI RAPIDI STÄUBLI / STÄUBLI QUICK COUPLING

		
<p>Description</p> <p>Innesto Femmina/ Female coupling</p> <p><u>3/8 x 24" UNF</u></p>	<p>06GS6200</p>	<p>€ 159,00 *</p>
		
<p>Description</p> <p>Innesto Maschio/ Male coupling</p> <p><u>3/8 x 24" UNF</u></p>	<p>06GS6201</p>	<p>€ 182,50 *</p>
		
<p>Description</p> <p>Innesto Maschio Occhio 25°/ 25° Male banjo coupling</p>	<p>06GS6230</p>	<p>€ 251,00 *</p>
		
<p>Description</p> <p>Adattatore Staubli - Tubazioni Global System/ Staubli - Global System Hoses Adaptor</p>	<p>06GS1330</p>	<p>€ 85,30 *</p>

* Attenzione! Prezzo netto per il negozio.

RACCORDI RECUPERABILI



Allegri[®]
TUBAZIONI RACING

FLEXIBLE
SOLUTIONS

motorquality
TECHNOLOGY FOR SPORT

**TUBI FRENO PER RACCORDI RECUPERABILI
HOSES FOR RE-USABLE FITTINGS SYSTEM**

		B. H.® Code	Description	€/dm	
TUBO A METRO (per raccordi recuperabili)		TUBO A METRO (per raccordi recuperabili)			
06403485	Tubo Aeronautico in treccia rivestito con guaina arancio	1,97	06403510	Tubo Aeronautico in treccia rivestito	1,50
06403430	Tubo Aeronautico in treccia	1,30	06403460	Tubo Aeronautico in treccia rivestito con guaina nera	1,97
06403480	Tubo Aeronautico in treccia rivestito blu	1,97	06403530	Tubo Aeronautico in treccia metallica dissip. cariche elettrostatiche	4,36
06403470	Tubo Aeronautico in treccia rivestito rosso	1,97	06403440	Tubo Aeronautico in treccia rivestito CarbonLook	1,97
06403490	Tubo Aeronautico in treccia rivestito verde	1,97			

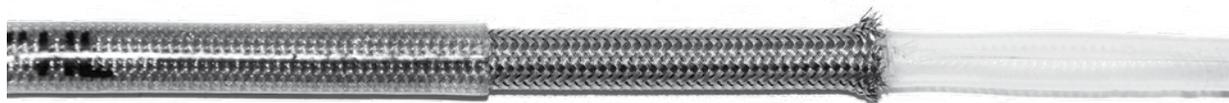

RACCORDI RECUPERABILI / RE-USABLE FITTINGS

Description	A	B	C
Occhiello Dritto/ Straight Banjo	0°	10,1	24
Occhiello Dritto/ Straight Banjo	0°	11,1	24
Occhiello Dritto/ Straight Banjo	0°	12,1	24
Occhiello 25°/ 25° Banjo	25°	10,1	23
Occhiello 45°/ 45° Banjo	45°	10,1	20
Occhiello 60°/ 60° Banjo	60°	10,1	18
Occhiello 90°/ 90° Banjo	90°	10,1	11

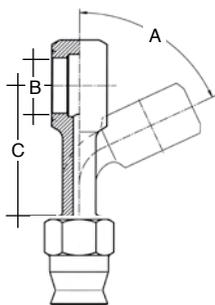

White Metal Silver	White Metal Gold	Light Alloy Blu	Light Alloy Rosso
06421114 7,00	06421116 6,70	06421111 11,90	06421117 11,90
06421113 7,40			
06421115 7,85			
06421193 7,70	06421196 7,40	06421191 12,75	06421197 12,75
06421173 7,70	06421176 7,50	06421171 12,60	06421177 12,60
06421163 7,80	06421166 7,50	06421161 12,90	06421167 12,90
06421183 7,80	06421186 7,50	06421181 12,60	06421187 12,60

Description	A	B	C
Occhiello Laterale 25°/ 25° Side Banjo	25°	10,1	23

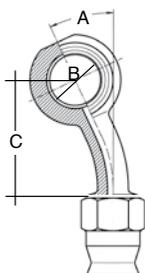

White Metal Silver	White Metal Gold	Light Alloy Blu	Light Alloy Rosso
06421413 7,80	06421416 7,50	06421411 12,90	06421417 12,90

Description	A	B
Occhiello Compatto/ Short Banjo	10,1	11

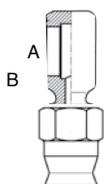

White Metal Silver	White Metal Gold	Light Alloy Blu	Light Alloy Rosso
06421013 7,55	06421016 7,30	06421011 10,30	06421017 10,30

Description	A	B	C
Occhiello doppio Comp. Straight Twin Banjo	10,1	10	10

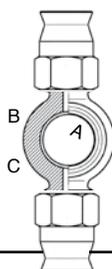

White Metal Silver	White Metal Gold	Light Alloy Blu	Light Alloy Rosso
06421313 14,70	06421316 18,50	06421311 19,10	06421317 19,10

RACCORDI RECUPERABILI / RE-USABLE FITTINGS

Description	A	C
Femmina Fissa Sede Svasata/ Fixed Female Concave Seat	M10x1 M10x1.25	22 22

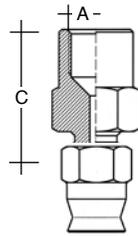

White Metal Silver	€
06404510	8,10
06404512	8,10

Description	A	C
Femmina Fissa con Gola Sede Svasata/ Fixed Female Concave Seat (clip fixing)	M10x1 M10x1.25 3/8" x 24 UNF	20 20 20

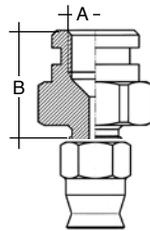

White Metal Silver	€
06404610	8,10
06404613	8,10
06404612	8,10

Per ottenere la sede da svasata ad ogiva, ordinare anche l'adattatore Cod. 06707070
For convex seat order adapter Code 06707070

Description	A	B	C	D
Femmina Girevole/ Swivel Female	0°	1/8" GAS	18	0
Femmina Girevole 45°/	45°	1/8" GAS	24	11
Femmina Girevole 90°/ 90° Swivel Female	90°	1/8" GAS	19	22

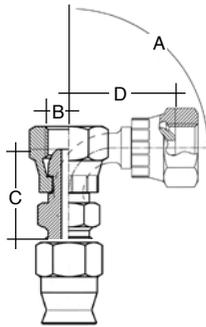

White Metal Silver	€
06404710	10,10
06404810	11,50
06404910	11,50

Description	A	B	C	D
Femm. Girevole/ Swivel Female	0°	3/8" x 24 UNF	13	0
Femm. Girevole 45°/ 45° Swivel Female	45°	3/8" x 24 UNF	27	10
Femm. Girevole 90°/ 90° Swivel Female	90°	3/8" x 24 UNF	20	22

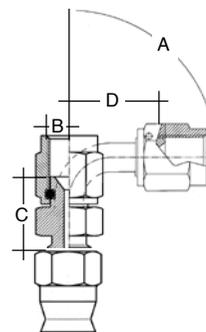

White Metal Silver	€
06404712	13,05
06404812	15,80
06404912	15,80

Description	A	B	C	D
Maschio Girevole/ Swivel Female	0°	M10x1 M10x1,25	29	0
Maschio Girevole 45°/ 45° Swivel Female	45°	M10x1 M10x1,25	39	20
Maschio Girevole 90°/ 90° Swivel Male	90°	M10x1 M10x1,25	21	30

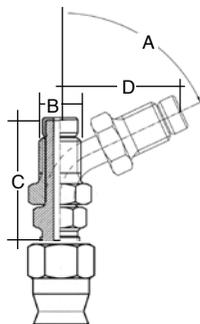

White Metal Silver	€	Light Alloy Blu	€
06504710	11,50	06504720	14,10
06504711	11,50	06504721	14,10
06504810	13,90	06504820	16,90
06504811	13,90	06504821	16,90
06504910	13,90	06504920	16,50
06504911	13,90	06504921	16,50

Description	A	B	Es.
Bullone Forato Testa Fresata/ Milled Banjo Bolt for Bleed	M10x1 M10x1,25 3/8" x 24 UNF 7/16 x 24 M12 x 1	19	12/14 12/14

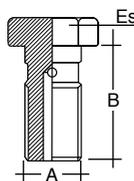

White Metal Silver	€	White Metal Gold	€	Light Alloy Blu	€	Light Alloy Rosso	€
06222847	2,60	06222850	3,15	06222862	4,70	06222882	4,70
06222848	2,20	06222851	3,15	06222863	4,85	06222883	4,85
06222846	1,70						
06220716	5,50						
06222849	9,40						

RACCORDI RECUPERABILI / RE-USABLE FITTINGS

Description	A	B	Es.
Bullone Forato Doppio/ Double Milled Banjo Bolt	M10x1	30	12/14
	M10x1,25	30	12/14
	3/8" x 24 UNF		

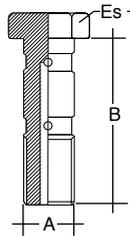

White Metal Silver	€	White Metal Gold	€	Light Alloy Blu	€	Light Alloy Rosso	€
06222827	2,70	06222852	3,60	06222860	4,70	06222880	4,70
06222828	2,40	06222853	3,60	06222861	5,60	06222881	5,60
06222826	2,20						

Description	A	B	C	Es.
Bullone Forato Fresata per Spurgo/ Milled Banjo Bolt for Bleed	M10x1	M6	21	12
	M10x1,25	M6	21	12

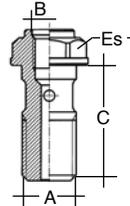

White Metal Silver	€	Light Alloy Giallo	€
06GS2373	7,60	06GS2371	8,25
06GS2392	7,20	06GS2914	9,20

Description	A	B	C	Es.
Bullone Forato Doppio Testa Fresata per Spurgo/ Double Milled Banjo Bolt for Bleed	M10x1	M6	32,5	12
	M10x1,25	M6	32,5	12

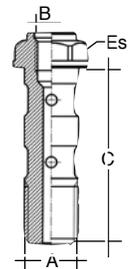

White Metal Silver	€	Light Alloy Giallo	€
06GS2364	9,60	06GS2368	9,90
06GS2365	9,60	06GS2369	9,90

Description	A	B	C
Bullone Testa Fresata/ Milled Banjo Bolt	M10x1	21	12/14
	M10x1,25	21	12/14

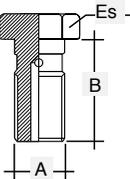

White Metal Silver	€	White Metal Gold	€	Light Alloy Blu	€	Light Alloy Rosso	€
06GS7533	6,90						
06GS2393	6,90						

Description	A	B	C
Bullone Doppio Testa Forata/ Double Milled Banjo Bolt	M10x1	32,5	12/14
	M10x1,25	32,5	12/14

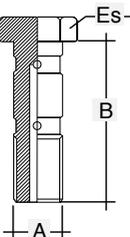

White Metal Silver	€	White Metal Gold	€	Light Alloy Blu	€	Light Alloy Rosso	€
06GS2362	8,25						
06GS2363	9,60						

Description	A	B	C
Tre Vie/ Three Hose Fittings	7	7	7

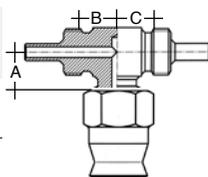

White Metal Silver	€	White Metal Gold	€	Light Alloy Blu	€	Light Alloy Rosso	€
06405114	20,20	06405116	19,90	06405112	26,60	06405117	26,60

Description	A	B	C	Es.
Tre Vie/ Three Hose Fittings	7	7	7	

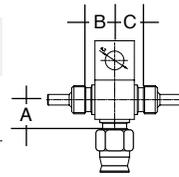

White Metal Silver	€	Light Alloy Blu	€
06405120	34,20		

Description	A	B	C	Es.
Vite spurgo/ Bleed screw	M6	5	21,7	7
	M10 x1	7	29	11

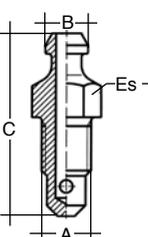

White Metal Silver	€	Light Alloy Blu	€
06GS2360	5,90	06GS2361	6,90
		06212810	6,05

RACCORDI RECUPERABILI / RE-USABLE FITTINGS

Description	Color	A	B
Cappuccio Plastica per Vite Spurgo/ Plastic Cup for Bleed Screw	Nero/Black	7,50	14

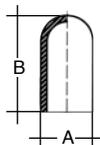

White Metal Silver €

06GS3697 0,70

Description
Ghiera + Olivetta/ Socket + Olive (Kit 5 Pz.)

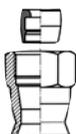

White Metal Silver € **White Metal Gold** € **White Metal Nero** € **Light Alloy Blu** €

06606060 11,40 | 06909090 11,40 | 06303030 22,85 | 06808080 15,00

ADATTATORI / ADAPTERS

Description	A	B	C
Bullone Forato con Femmina/ Banjo Bolt with Female	M10x1	M10x1	32

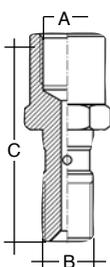

White Metal Silver €

06222830 8,48

Description	A	B	C
Adattatore Femmina-Femmina/ Coupling Fixed Female	M10x1	M10x1	24

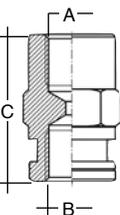

White Metal Silver €

06415310 6,80

Description	A	B	C
Adattatore Femmina-Maschio/ Female Conector	M10x1 M10x1,2 1/8" GAS	1/8" GAS 1/8" GAS 1/8" GAS	25 25 28

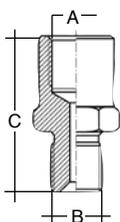

White Metal Silver €

06405210 3,05
06405211 13,35
06405213 16,70

Description	A	B	C
Adattatore Maschio-Maschio/ Male Adaptors	3/8"x24 UNF	1/8" GAS	27

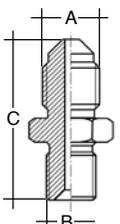

White Metal Silver €

06405012 2,05

Description	A	B	C
Adattatore Maschio-Maschio/ Male Adaptors	M10x1 M10x1,25 1/8" GAS	1/8" GAS 1/8" GAS 1/8" GAS	28 28 28

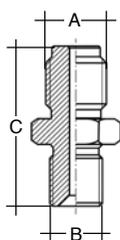

White Metal €

06405010 3,10
06405011 3,35
06405013 8,15

Description	A
Riduzione Occhio Femmina/ Banjo Adaptors with Female	0° 25°
Riduzione Occhio Femmina D.12/ Banjo Adaptors with Female	0°

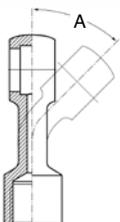

White Metal €

06421210 7,00
06421290 8,30
06GS4049 13,50



Description	A	B
Adattatore Bicono/ Biconical Adapter	8,5	6

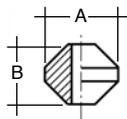

Code	€
06707070	0,80

ACCESSORI / ACCESSORIES

Description	A
Rondella/Washer	10 11

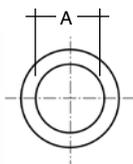

Alluminio / Aluminum	€	Rame / Copper	€
06219614	0,10	06219613	0,10
06219615	0,27	-	-

Description	A	B	C
Gommino Passante/ Rafter End	7	18	4
	7	15	4
	10	13	3

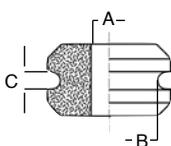

Code	€
06GS1121	1,50
06GS1453	1,45

Description	A	B	C
Gommino Riduzione/ Reduced Coupling	6,5	10	48

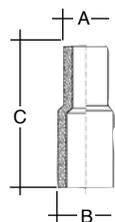

Code	€
06GS0083	2,05

Description	A	B	C
Gommino Flangiato/ Gom Elastic	7	12	16
	7	14	20
	10	16	12

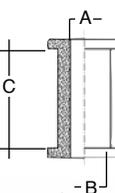

Code	€
06GS0206	0,90
06GS0182	0,65

Description
Cappucci Gomma Termoretraibili/ Gom Elastic Sleeve Heat-Shrinkable



Code	€
06GS6054	1,10

Description	ØI	ØE
Tubo per Fluido/ Brake Fluid Hose	6,5	10,5



Code	€/dm
6505	1,00

Description	Code	€
Tappo Maschio/ Male Plug	Hy-7260	6,20

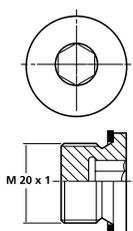

GUAINA / COVERINGS

Description	Code	€/dm
Guaina Termoretraibile Trasparente	1960GTF	0,45
Guaina Termoretraibile Blu	1990GTFB	0,77
Guaina Termoretraibile Rossa	1990GTFR	0,77
Guaina semirigida	1961GTS	0,45
Guaina Spirale	1959SPR	0,90
Guaina Spirale azzurra	1959SPRA	0,90
Guaina Spirale rossa	1959SPRR	0,90
Guaina Spirale nera	1959SPRN	0,90

ATTREZZATURE / TOOLINGS

Description	Code	€/dm
Spanditore	06GS0056	24,70

CATENE

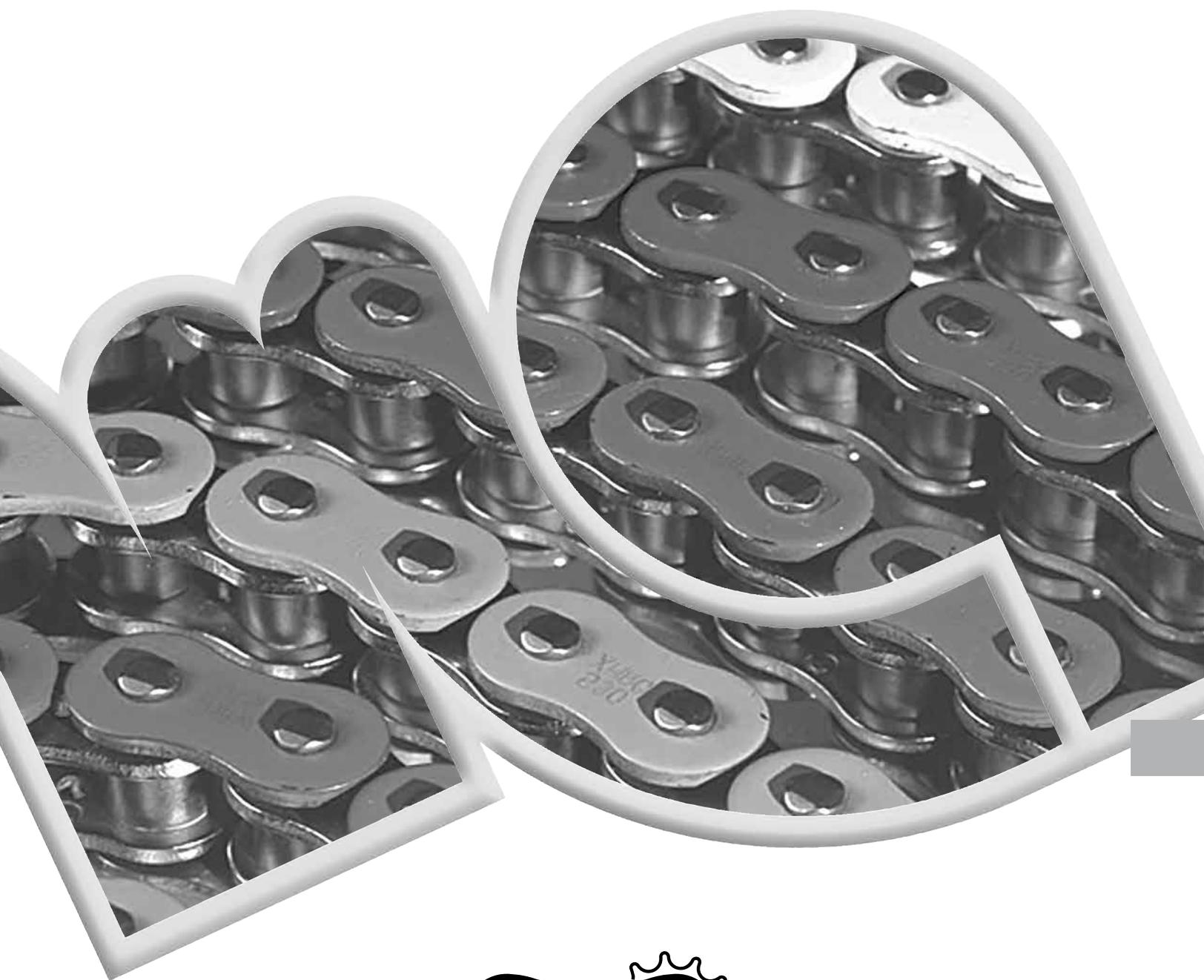



APPLICAZIONI CONSIGLIATE / SUGGESTED APPLICATIONS

Catena Afam / Afam Chain						Strada					Cross Enduro Rac.			Enduro Stradale								
Mod.	XS-ring	Bussole Trafilate	Spessore Piastrine	Resistenza (KN)	Oro	80	125	350	600	750	1000	Over	80	125	250	450	80	125	350	600	Over	
415 S	NO	SI	1,6/1,8	17,0	NO	●																
420 M	NO	SI	1,5	20,0	NO	●																
420 R1G	NO	SI	1,8	21,0	SI	●							●				●					
420 MXG	NO	SI	2,0	24,0	SI								●				●					
428 M	NO	SI	1,5	20,0	NO	●											●	●				
428 MXG	NO	SI	1,8	20,0	SI	●							●				●					
428 R1G	NO	SI	1,8	22,0	SI	●							●				●					
520 M	NO	SI	2,0	31,0	NO	●											●					
520 MR1G	NO	SI	2,0	34,0	SI	●								●	●	●		●				
520 MX3G	NO	SI	2,0	37,4	SI									●	●	●						
520 XLR	SI	SI	2,0	33,0	NO	●	●						●	●	●		●	●				
520 XMR2	SI	SI	2,4	37,0	NO	●	●	●					●	●	●	●		●	●			
520 XRR	SI	SI	2,0	36,0	SI	●	●	●					●	●	●	●		●	●			
520 XSMG	SI	SI	2,0	38,4	SI								●	●	●	●		●	●			
520 XSRG	SI	SI	2,0	36,2	SI			●	●				●	●	●							
520 XHRG	SI	SI	2,2	41,2	SI			●	●	●	●	●										●
525 XMR2	SI	SI	2,4	37,0	NO		●	●														●
525 XRR	SI	SI	2,2	39,1	NO		●	●														●
525 XSRG	SI	SI	2,2	41,8	SI			●	●													●
525 XHRG	SI	SI	2,4	43,9	SI			●	●	●	●											
50 HS	NO	SI	2,2	35,6	NO		●															
530 XMR2	SI	SI	2,4	38,5	NO		●	●	●													
50 XRR	SI	SI	2,4	39,1	NO		●	●	●													
50 XSRG	SI	SI	2,4	41,8	SI			●	●	●												●
50 XHRG	SI	SI	2,6/2,4	46,8	SI			●	●	●	●											●
532 ZVO	SI	SI	2,4/2,6	47,1	NO			●	●	●	●											
630 MO	NO	SI	2,4	45,1	NO			●	●	●												

CATENE / CHAINS

Codice	Catena tipo	n° maglie	€	Codice	Catena tipo	n° maglie	€
415S130	415 S	130 M.	22,00	520XSMG120	520 XSMG	120 M.	120,00
420M124	420 M	124 M.	20,00	520XLR120	520 XLR	120 M.	78,00
420M126	420 M	126 M.	20,35	520XMR2118	520 XMR2	118 M.	90,00
420M132	420 M	132 M.	21,10	520XMR2122	520 XMR2	122 M.	96,00
420M140	420 M	140 M.	22,70	520XRR100	520 XRR	100 M.	79,00
420R1G140	420 R1G	140 M.	35,00	520XRR110	520 XRR	110 M.	87,00
420MXG132	420 MXG	132 M.	47,00	520XRR112	520 XRR	112 M.	89,00
428M136	428 M	136 M.	20,40	520XRR118	520 XRR	118 M.	93,00
428M140	428 M	140 M.	21,00	520XRR120	520 XRR	120 M.	95,00
428R1G140	428 M	140 M.	28,00	520XSRG102	520 XSRG	102 M.	113,00
428MXG140	428 MXG	140 M.	78,00	520XSRG106	520 XSRG	106 M.	116,00
520M106	520 M	106 M.	28,30	520XSRG110	520 XSRG	110 M.	123,00
520M110	520 M	110 M.	29,40	520XSRG112	520 XSRG	112 M.	125,00
520M112	520 M	112 M.	29,95	520XSRG120	520 XSRG	120 M.	134,00
520M114	520 M	114 M.	30,50	520XHRG98	520 XHRG	98 M.	139,00
520M116	520 M	116 M.	31,00	520XHRG102	520 XHRG	102 M.	145,00
520M120	520 M	120 M.	32,00	520XHRG108	520 XHRG	108 M.	154,00
520MR1G118	520 MR1G	120 M.	48,00	520XHRG110	520 XHRG	110 M.	156,00
520MR1G120	520 MR1G	120 M.	49,00	520XHRG120	520 XHRG	120 M.	170,00
520MX3G120	520 MX3G	120 M.	86,00	520XHRG122	520 XHRG	122 M.	173,00
				525XMR2120	525 XMR2	120 M.	112,00
				525XMR2124	525 XMR2	124 M.	118,00



CATENE / CHAINS

Codice	Catena tipo	n° maglie	€	Codice	Catena tipo	n° maglie	€
525XRR108	525 XRR	108 M.	113,00	530XMR2120	530 XMR2	120 M.	112,00
525XRR110	525 XRR	110 M.	115,00	50XRR108	530 XRR	108 M.	113,00
525XRR112	525 XRR	112 M.	117,00	50XRR110	530 XRR	110 M.	115,00
525XRR114	525 XRR	114 M.	119,00	50XRR112	530 XRR	112 M.	117,00
525XRR116	525 XRR	116 M.	122,00	50XRR114	530 XRR	114 M.	120,00
525XRR118	525 XRR	118 M.	124,00	50XRR118	530 XRR	118 M.	123,00
525XRR120	525 XRR	120 M.	126,00	50XRR120	530 XRR	120 M.	126,00
525XRR124	525 XRR	124 M.	130,00	50XSRG108	530 XSRG	108 M.	157,00
525XSRG108	525 XSRG	108 M.	126,00	50XSRG110	530 XSRG	110 M.	160,00
525XSRG112	525 XSRG	112 M.	130,00	50XSRG114	530 XSRG	114 M.	166,00
525XSRG114	525 XSRG	114 M.	133,00	50XSRG116	530 XSRG	116 M.	169,00
525XSRG120	525 XSRG	120 M.	139,00	50XSRG120	530 XSRG	120 M.	175,00
525XSRG124	525 XSRG	124 M.	144,00	50XSRG122	530 XSRG	122 M.	178,00
525XHRG96	525 XHRG	96 M.	140,00	50XHRG108	530 XHRG	108 M.	216,00
525XHRG98	525 XHRG	98 M.	143,00	50XHRG110	530 XHRG	110 M.	220,00
525XHRG102	525 XHRG	102 M.	149,00	50XHRG114	530 XHRG	114 M.	228,00
525XHRG106	525 XHRG	106 M.	155,00	50XHRG116	530 XHRG	116 M.	232,00
525XHRG108	525 XHRG	108 M.	158,00	50XHRG118	530 XHRG	118 M.	236,00
525XHRG110	525 XHRG	110 M.	161,00	50XHRG122	530 XHRG	122 M.	244,00
525XHRG112	525 XHRG	112 M.	164,00	532ZVX116	532 ZVX	116 M.	243,00
525XHRG116	525 XHRG	116 M.	170,00	532ZVX122	532 ZVX	122 M.	256,00
525XHRG118	525 XHRG	118 M.	173,00	630MO102	630 MO	102 M.	186,00
525XHRG124	525 XHRG	124 M.	181,00				
50HS110	530 HR	110 M.	79,00				

CATENA RACING 3D #520 / 3D RACING CHAIN #520

Codice	Catena tipo	n° maglie	€	
520GP3D120	520 3D	120 M.	220,00	Prezzo netto per negozio
MLJ3D520GP	Giunto per catena 520 3D		8,00	

GIUNTI CATENE / RIVETTED JOINT CHAIN

Codice	Descrizione	€	Codice	Descrizione	€
AR415S	giunto a clip	1,75	MRS520XHRG	giunto ad espandere	7,50
AR420M	giunto a clip	1,85	MRSA525XMR2	giunto ad espandere	4,90
AR420R1G	giunto a clip	2,05	MRS525XMR	giunto ad espandere	5,15
AR420MXG	giunto a clip	2,80	MRS525XRR	giunto ad espandere	7,50
AR428M	giunto a clip	1,95	MRS525XSRG	giunto ad espandere	8,00
AR428R1G	giunto a clip	1,95	MRS525XHRG	giunto ad espandere	8,60
ARS428MXG	giunto a clip rinforzato	4,10	MRSA530XMR2	giunto ad espandere	5,60
AR520M	giunto a clip	2,55	MRS50HS	giunto ad espandere	5,00
ARS520MR1G	giunto a clip rinforzato	2,80	MRS50XRR	giunto ad espandere	8,00
ARS520MX3G	giunto a clip rinforzato	4,35	MRS50XSRG	giunto ad espandere	8,50
ARS520XLR	giunto a clip rinforzato	5,15	MRS50XHRG	giunto ad espandere	9,20
ARS520XRR2G	giunto a clip rinforzato	5,50	MRS532ZVX	giunto ad espandere	10,50
MRS520XRR2G	giunto ad espandere	5,50	MRS630MO	giunto ad espandere	8,00
ARS520XSRG	giunto a clip rinforzato	7,16	MRSA520XMR2	giunto ad espandere	4,50
MRSA520XMR2	giunto ad espandere	4,50	MRSA525XMR2	giunto ad espandere	4,90
MRS520XSRG	giunto ad espandere	7,66	MRSA530XMR2	giunto ad espandere	5,60

CORONE E PIGNONI OFF-ROAD





OFF-ROAD

Modello	Anno	Passo	Pignone codice (vedi listino singolo per range) -/+ (con scarico)	Corona acc. codice (vedi listino singolo per range) -/SLK + (con scarico)	Corona all. codice (vedi listino singolo per range) -/+ (con scarico)	Corona all. col. codice (vedi listino singolo per range) PB PR PK PO R
APRILIA						
50 MX/SM/RX/RX Racing	'99→'05	420	94119	35103		
50 RX # 420	'95→'98	420	94109	35103		
50 RX SX	'06→'16	420	49102	47103		
50 SX	'12→'16	420	49102	92114		
125 MX	'03→'07	520	61201	35204		
125 RX R	'90→'92	520	61201	35204		
125 RX E/RX/SX	'93→'11	520	61201	35204		
125 RX IE	'18→'20	428	49200	47203		
240/280 Climber		520	61201		36305	
300 TX Rotax/310/311/240TX/ 312TXR	'86→'89	520	61300		60300	
450 MXV/RXV	'06→'11	520	37400		36400	
550 RXV/ SXV	'06→'11	520	37400		36400	
AJP						
125 Black Bird/Enduro PR4/SM	'04→'11	428	20200	92213		
125/200 Enduro/Supermoto PRO PR3	'08→'11	428	20200	10110		
200 Enduro/PR4	'04→'11	428	20200	92213		
125/200 Enduro PR4 Reinforced	'04→'11	520	20202	14206	15206	
BETA						
50 RR	'97	428	94202		60103	
50 RR	'98→'01	428	94202		93111	
50 RR	'02→'05	420	94119	92115		
50 RR Racing "Alu"	'03→'06	428	94118		93117	
50 RR/Factory/Standard/Sport/ Racing	'05→'20	420	94119	38101		
50 RR SM	'98→'00	428	94202			
50 RR SM	'01→	428	94202	92113		
50 RR SM	'02→'05	420	94119	92115		
50 RR SM/Sandard/Track	'05→'16	420	94119	38101		
80 REV	'02→'08	428	94202		39100	
80 EVO	'09→'10	428	94202		93118	
125 EVO	'09→'16	520	40300		93320	
125 REV 3	'06→'08	520	40300		93320	
125 RR	'06→'11	428	21207	38200		
Evo 125 Factory	'19	520	40300			
RR 125 Enduro/Enduro Racing	'18→'21	520	73301	38300	39300	
125 RR/RE/Motard	'06→'16	428	21207	38200		
125 RR LC/LC Motard	'12→'16	428	21208	38200		
125 SM M4	'06→'09	428	21207	38200		
125 ALP 4T	'01→'03	428	22201			
200 Alp 4T	'00→'03	520	22303		93321	
200 Evo	'09→'21	520	40300		93320	
200 RR Enduro	'19→'20	520	73301	38300	39300	
240 Techno	'96→'97	520	94301		60201	
247 REV 3	'01→'02	520	40300		60201	
250 EVO/4 Strokes/REV 3	'09→'16	520	40300		93320	
250/300 X-Trainer	'19→'21	520	73301	38300	39300	
Evo 250 Factory	'19→'20	520	40300		93320	
250 RR	'05→'07	520	73301		15206	
250 RR 2T/EFI	'13→'16	520	73301		39300	
270 REV 3	'03→'08	520	40300		93320	
290/300 EVO/EVO 4 Strokes	'09→'16	520	40300		93320	



OFF-ROAD

Modello	Anno	Passo	Pignone codice (vedi listino singolo per range) -/+ (con scarico)	Corona acc. codice (vedi listino singolo per range) -/SLK + (con scarico)	Corona all. codice (vedi listino singolo per range) -/+ (con scarico)	Corona all. col. codice (vedi listino singolo per range) PB PR PK PO R
300 RR 2T/EFI	'13→'16	520	73301		39300	
RR 300 Enduro/Enduro Racing	'20→'21	520	73301	38300	39300	
350 Jonathan	'03→'04	520	22303	35304		
350 RR	'12	520	73301	14206	15206	
350 RR/RR-S/EFI Enduro Enduro Racing	'13→'21	520	73301	38300	39300	
RR 390 EFI Enduro/Enduro Racing Enduro 4T	'20→'21	520	73301	38300	39300	
400 RR	'05→'11	520	73301	14206	15206	
400/430 RR/EFI	'13→'16	520	73301		39300	
430/480 RR EFI Enduro Enduro Racing	'20→'21	520	73301	38300	39300	
450 RR	'05→'14	520	73301	14206	15206	
450 RR	'13→'14	520	73301		39300	
480 RR/EFI	'15→'16	520	73301		39300	
498 RR	'12→'12	520	73301	14206	15206	
498 RR	'13→'14	520	73301		39300	
520 RR	'10→'11	520	73301	14206	15206	
525 RR	'05→'09	520	73301	14206	15206	
BMW						
G 450 X	'08→'09	520	16640		36400	
G 450 X	'08→'09	520			36400	
F 650 Funduro/Strada	'93→'00	520	61301	35304		
F 650 GS/Dakar	'99→'06	520	61301	35304		
CAGIVA						
125 WMX	'89→'92	520	46202	14206	15206	
250 WMX	'89→'90	520	24302	14206	15206	
FANTIC						
50 Caballero Régolarita	'06→'09	420	94119	92115		
50 Caballero Motard SM	'06→'09	420	94119	92115		
125 Trial TX250		428	55201		54102	
200 Trial TX350		428	55201		60101	
240 Trial TX450 /245/247 KRO	'89→'90	520	55300		60300	
305/307KRO						
249/249 R Section Caosta	'95→'97	520	55300		78303	
GAS-GAS						
50 ROOKIE SM/EC	'02→'05	420	58102	47103		
80 TXT	'02→'06	420	58102		93118	
125 CR Cross	'94→'95	520		14206	15206	
125 Enduro	'99	520		14206	15206	
125 Enduro	'01→'02	520	21203	14206	15206	
125 EC Enduro	'03→'15	520	21203	14206	15206	
MC 125	'21→'21	520	73301	71304	72304	72304
EC 200 E4/ Ranger/XC	'18→'20	520	94313	14206	15206	15206
CONTACT 250 RR	'20	520	97200	93320		
125 JT12/TXT		520	94305		93303	
125 MC Cross	'02→'05	520	21203	14206	15206	
125 Pampera	'92→'01	520	94305		93303	
125 TXT (JT12)	'00	520	94305		93303	
125 TXT	'02→'03	520	97200			
125 TXT Trial GP/Racing	'04→'20	520	97200		93320	
160 JT16	'93→'94	520	94305		93303	



OFF-ROAD

Modello	Anno	Passo	Pignone codice (vedi listino singolo per range) -/+ (con scarico)	Corona acc. codice (vedi listino singolo per range) -/SLK + (con scarico)	Corona all. codice (vedi listino singolo per range) -/+ (con scarico)	Corona all. col. codice (vedi listino singolo per range) PB PR PK PO R
200 EC Enduro	'00→'02	520	94313	14206	15206	
200 EC/R Enduro	'03→'15	520	94313	14206	15206	
200 ECE/ER Enduro	'14→'15	520	94313	14206	15206	
200 TXT Trial	'00	520	94305		93303	
200 TXT Trial	'02→'03	520	97200			
240 Trial	'91	520	94305		93303	
240 JT25 Trial	'95	520	94305		93303	
249 TXT Trial	'99→'01	520	94305		93303	
250 Enduro	'96	520	94312	14206	15206	15206
250 EC Enduro	'97→'00	520	94313	14206	15206	
250 EC/R Enduro	'01→'15	520	94313	14206	15206	
250 ECE/ER Enduro	'14→'15	520	94313	14206	15206	
250 EC-F Enduro 4 stroke	'10→'15	520	21309	14206	15206	
250 XC	'18→'19	520	94313	14206	15206	
250 EC	'21	520	73301	71304	72304	72304
250 MC Cross	'02→'05	520	94313	14206	15206	
250 Pampera	'01	520	94305		93303	
250 Pampera	'02→'03	520	94305		93323	
250 TXT Trial	'02→'14	520	97200		93320	
EC 250 E4/Enduro GP/Six Days	'18→'19	520	94313	14206	15206	
EC-F 250	'21	520	73301	71304	72304	
MC-F 250	'21	520	73301	71304	72304	
250 TXT/TXT Pro Trial	'15→'17	520	97200		93320	
250 TXT GP Trial Limited édition	'17	520	97200		93320	
250 Wild Quad	'04	520	94313	95300		
270 TX Trial	'96→'99	520	94305		93303	
280 TXT Trial	'00→'01	520	94305		93303	
280 TXT Pro Trial	'02→'14	520	97200		93320	
280 TXT/TXT Pro Trial	'15→'17	520	97200		93320	
280 TXT GP Trial Limited édition	'17	520	97200		93320	
280 CONTACT RR	'20	520	97200		93320	
300 EC Enduro	'00	520	94313		15206	
300 EC/R Enduro	'01→'15	520	94313	14206	15206	
300 EC-F Enduro 4 stroke	'13→'15	520	21309	14206	15206	
300 EC	'21	520	73301	71304	72304	72304
300 EC E4/E4 GP/E4 Six Days	'18→'20	520	94313	14206	15206	15206
300 EC Ranger	'19→'20	520	94313	14206	15206	15206
300 XC	'18→'19	520	94313	14206	15206	15206
350 EC-F/450 MC-F	'21→'21	520	73301	71304	72304	72304
300 TXT Trial	'04→'13	520	97200		93320	
300 TXT /TXT Pro Trial	'15→'17	520	97200		93320	
300 TXT GP Trial Limited édition	'17	520	97200		93320	
300 Wild Quad	'04→'05	520	94313	95300		
320 TX Contact Trial	'98	520	94305		93303	
321 TXT Trial	'00→'01	520	94305		93303	
400 FSE SM	'02	520	94313			
400 FSE EC Enduro	'02	520	94313	14206	15206	
400 Wild Quad	'03	520	94313	95300		
450 FSE SM	'03→'04	520	94313			
450 FSE / EC-F Enduro	'03→'15	520	94313	14206	15206	
450 Wild Quad	'04→'05	520	94313	95300		

HM / HONDA

50 CRE Baja	'03→'16	428	94121	47200	48200	
50 CRE Baja RR	'09→'16	428	94121	47200	48200	
50 CRE End	'01	428	94118		93110	
50 CRE End	'02	428	94118		60104	



OFF-ROAD

Modello	Anno	Passo	Pignone codice (vedi listino singolo per range) -/+ (con scarico)	Corona acc. codice (vedi listino singolo per range) -/SLK + (con scarico)	Corona all. codice (vedi listino singolo per range) -/+ (con scarico)	Corona all. col. codice (vedi listino singolo per range) PB PR PK PO R
50 CRE Six	'04→'10	428	94121	47200	48200	
50 CRM Derapage	'02	428	94118		60104	
50 CRM Derapage	'03→'16	428	94121	47200	48200	
50 CRM Derapage RR	'09→'16	428	94121	47200	48200	
50 CRM Derapage Competition	'04→'10	428	94121		48200	
125 CRE RR 2T	'11→'16	520	61201	14206	15206	
125 CRE F X 4T	'09→'10	428			11228	
125 CRE F RR 4T	'10	428			11228	
125 CRE F 4T	'11→'16	428	21208	47200	48200	
125 CRE F RR 4T	'11→'16	428	21208	47200	48200	
125 CRM RR 2T	'11→'16	520	61201	14206	15206	
125 CRM F X 4T	'09→'10	428	21208	10228		
125 CRM F 4T	'11→'16	428	21208	47200	48200	
125 CRM FRR 4T	'11→'16	428	21208	47200	48200	
125 CRE R	'03	520	20206	10212	11212	11212
125 CRE R	'04→'06	520	20210	10212	11212	11212
230 CRF EASY	'04→'09	520		10212	11212	11212
250 CRE R	'03→'06	520	20311	10212	11212	
250 CRE F	'04→'16	520	20210	10212	11212	11212
250 CRE F- X starter	'05→'16	520	20210	10212	11212	
300 CRE F	'12→'16	520	20210	10212	11212	11212
300 CRE X starter	'09→'16	520	20210	10212	11212	
400 DALL'ARA	'06→'07	520	20314	16302		
450 CRM F	'04→'08	520	20311	10212	11212	
450 CRM F-X starter	'07→'08	520	20311	10212	11212	
450 CRE F	'03→'16	520	20311	10212	11212	11212
450 CRE F-X starter	'05→'16	520	20311	10212	11212	11212
500 CRE F	'12→'16	520	20311	10212	11212	11212
500 CRE F-X starter	'09→'16	520	20311	10212	11212	11212

HONDA

50 CR	'83→'85	420	20103			
50 CRF	'04→'09	420	20105		11113	
50 CRF	'10→'18	420	20105		11113	
80 CR R	'81	420	20104	10103		
80 CR R	'82	420	20101			
80 CR R	'83	420	20103			
80 CR R	'84→'85	420	20101			
80 CR R	'86→'02	420	20105		11104	
80 CR R T # 428 chain	'96→'02	428	20108		11111	
80 CR R2 F Big Wheels	'85	420	20101	10103		
80 CR R2 G Big Wheels	'86	420	20105	10103		
80 CR R2 T-2 Big Wheels	'96→'02	420	20105		11104	
80 CR R2 T-2 Big Wheels # 428	'96→'02	428	20108			
80 CR R2 T-2 Big Wheels # 428	'96→'02	428			11111	
80 CRF	'04→'09	420	20101		11101	
80 CRF	'10→'12	420	20101		11101	
80 XR R	'85	420	20101		11101	
85 CR R	'03→'07	420	20105		11104	
85 CR R/R-B # 428 chain	'03→'07	428	20108		11111	
85 CR R-B	'03→'04	420	20105			
85 CR R-B	'05→'07	420	20105		11104	
100 CRF	'04→'13	428	20107		11110	
125 CR R	'79→'82	520	20202			
125 CR R	'83	520	20202	10212	11212	
125 CR R	'84→'86	520	20204	10212	11212	11212
125 CR R	'87→'03	520	20206	10212	11212	11212



OFF-ROAD

Modello	Anno	Passo	Pignone codice (vedi listino singolo per range) -/+ (con scarico)	Corona acc. codice (vedi listino singolo per range) -/SLK + (con scarico)	Corona all. codice (vedi listino singolo per range) -/+ (con scarico)	Corona all. col. codice (vedi listino singolo per range) PB PR PK PO R
125 CR R	'04→'07	520	20210	10212	11212	11212
125 CRF F Small Wheels	'14→'18	428	20114	10110		
125 CRM	'90→'94	520	20305	10215		
150 CRF	'03→'16	520	20305	10212	11212	
150 CRF R	'07→'16	420	20211		11104	
150 CRF R # 428 Chain	'07→'16	428	20212		11111	
150 CRF R-B	'07→'16	420	20211		11104	
150 CRF R-B # 428 Chain	'07→'16	428	20212			
230 CRF F A-G	'04→'16		20305	10212	11212	11212
250 CR R	'79→'83	520	20308			
250 CR R	'84→'85	520	20309	10212	11212	11212
250 CR R	'86→'87	520	20310	10212	11212	
250 CR R	'88→'07	520	20311	10212	11212	11212
250 CRF R	'04→'09	520	20210	10212	11212	11212
250 CRF R	'11→'17	520	20210	10212	11212	11212
250 CRF R	'18	520	20324	10212	11212	11212
250 CRF L/LA/ Rally/ M	'12→'18	520	20320	10320	-	
250 CRE F-X starter	'04→'16	520	20210	10212	11212	
450 CR /CR 480 R	'81→'83	520	20308			
450 CRF R/F/X starter	'02→'18	520	20311	10212	11212	11212
500 CR R	'84→'85	520	20309	10212	11212	11212
500 CR R	'86→'87	520	20310	10212	11212	11212
500 CR R	'88→'00	520	20311	10212	11212	11212

HRD

50 Enduro/GS/SM / Sonic	'91→'09	428	94118		60104	
-------------------------	---------	-----	-------	--	-------	--

HUSABERG

125 TE/250 TE/300 TE - FE	'11→'13	520	73301	71304	72304	72304
350 Enduro	'92→'95	520	64302		93501	
350 FC/400/501/600 4 Speed	'96→'99	520	64302			
350 FC/FE/400/501/600 6 Speed	'96→'99	520	64302		93501	
350 FC/FE/400/501/600 4 Speed	'00→'01	520	64302	71304	72304	72304
350 FE/390 FE e	'11→'13	520	73301	71304	72304	72304
350 TE	'96→'99	520	64302		93501	
400 FE-FC /450 FE - FC	'00→'08	520	64302	71304	72304	72304
450 FE e/570 FE e	'09→'13	520	73301	71304	72304	72304
501 FE /600 FE/600 SM	'00→'08	520	64302	71304	72304	72304
501 FE-FC e/550 FE-FC	'03→'08	520	64302	71304	72304	72304
600 Enduro	'93→'95	520	64302		93501	

HUSQVARNA

50 TC	'17→'18	415	94124		72106	
65 CR	'12→'13	420	94120		72101	
65 TC	'17→'18	420	94120		72101	
85 TC BW/SW	'14→'18	428	94202		72102	
125 CR	'77→'85	520	64300		63300	
125 CR	'90→'94	520	46202	14206	15206	
125 CR	'95→'97	520	64200	14206	15206	
125 CR	'98→'13	520	64201	14206	15206	
125 TC/TE	'14→'18	520	73301	71304	72304	72304
125 TE 4T/SMS4 125 4T	'11→'13	428	21208	14205		
125 TC	'20→'21	520	73301	71304	72304	72304
150 TE	'18→'21	520	73301	71304	72304	72304
125 SMS	'00→'12	520	64200	14206	15206	
125 WR	'77→'82	520	64300		63300	
125 WR/XC	'83→'85	520	64302		63300	



OFF-ROAD

Modello	Anno	Passo	Pignone codice (vedi listino singolo per range) -/+ (con scarico)	Corona acc. codice (vedi listino singolo per range) -/SLK + (con scarico)	Corona all. codice (vedi listino singolo per range) -/+ (con scarico)	Corona all. col. codice (vedi listino singolo per range) PB PR PK PO R
125 WRB monochoc	'85	520	64302			
125 WRK 125	'89	520	46202			
125 WR	'90→'94	520	46202	14206	15206	
125 WR	'95→'97	520	64200	14206	15206	
125 WR	'98→'13	520	64201	14206	15206	
125 WRE	'04→'12	520	64200	14206	15206	15206
240/250 CR	'77→'88	520	64300		63300	
250 CR	'90→'97	520	24302	14206	15206	
250 CR	'99→'04	520	64500	14206	15206	
250 FC/FE	'14→'18	520	73301	71304	72304	72304
250 TC	'02→'13	520	64500	14206	15206	
250 TC	'14→'18	520	73301	71304	72304	72304
250 TXC	'08→'10	520	64500	14206	15206	
250 TXC	'08→'10	520	64500	14206	15206	
250 TXC/TE	'10→'13	520	64305	14206	15206	
250 TE	'02→'09	520	64500	14206	15206	
250 TE /250 i	'14→'17	520	73301	71304	72304	72304
250 TC /250 TE i	'18→'21	520	73301	71304	72304	72304
300 TX i /FX350/701 LR Enduro	'18→'21	520	73301	71304	72304	72304
240 WR	'77→'79	520	64300		63300	
240-250 WR/XC	'83→'85	520	64302		63300	
240-260 WRK / WR	'89→'99	520	24302	14206	15206	
250-300 WR	'00→'13	520	64500	14206	15206	
300 TE	'14→'17	520	73301	71304	72304	72304
310-350 TE	'09→'12	520	64500	14206	15206	15206
350 FC	'14→'18	520	73301	71304	72304	72304
350 WR	'81→'88	520	64302		63300	
360 CR/WR	'92→'99	520	24302	14206	15206	
360 WR	'00	520	64500	14206	15206	
390-430 CR/WR	'77→'84	520	64300		63300	
400 TE	'98→'02	520	64500	14206	15206	
400 WR	'84→'85	520	64302		63300	
410 TE	'98→'01	520	64500	14206	15206	
430 CR/WR	'80→'84	520	64302		63300	
449 TC/TE	'10→'12	520	16640	14206	15206	
450 FC/FE	'14→'18	520	73301	71304	72304	72304
450 TC/TE/SMR	'02→'10	520	64500	14206	15206	
500 CR	'85	520	64302		63300	
500-510 TC/TE-TC/TE	'85→'89	520	64302			
501 FE	'14→'18	520	73301	71304	72304	72304
510 TC	'90→'09	520	64500		15206	
TE/SMR 510	'90→'11	520	64500	14206	15206	
511 TE	'12	520		14206	15206	
570 TC/TE/SMR -610 TC TE/SM E/SMS	'02→'04	520	64500	14206	15206	

KAWASAKI

80 KX	'79→'80	428	28200			
80 KX	'81→'85	420	30100			
80 KX	'86→'88	420	30100		17104	
80 KX # 428	'83→'87	428	24100			
80 KX Small wheels	'89→'00	420	30100		17104	
80 KX Small wheels # 428	'89→'97	428	24100			
80 KX Small wheels # 428	'98→'00	428	24100		17105	
80 KX Big wheels	'86→'00	420	30100		17104	
80 KX Big wheels # 428	'92→'00	428	24100		17105	
85 KX Small wheels	'01→'18	420	30100		17104	



OFF-ROAD

Modello	Anno	Passo	Pignone codice (vedi listino singolo per range) -/+ (con scarico)	Corona acc. codice (vedi listino singolo per range) -/SLK + (con scarico)	Corona all. codice (vedi listino singolo per range) -/+ (con scarico)	Corona all. col. codice (vedi listino singolo per range) PB PR PK PO R
85 KX Small wheels # 428	'01→'18	428	24100		17105	
85 KX Big wheels	'01→'18	420	30100		17104	
85 KX Big wheels # 428	'01→'18	428	24100		17105	
100 KX	'87→'13	420	30100		17104	
100 KX # 428	'87→'90	428	24100			
100 KX # 428	'91→'96	428	24100		17105	
100 KX # 428	'96→'97	428	24100			
100 KX # 428	'98→'13	428	24100		17105	
125 KX	'80→'81	520	30200			
125 KX	'82→'93	520	30200	16204	17206	
125 KX	'94→'08	520	24201	16206	17206	17206
250 KX	'82→'86	520	24302	16204	17206	17206
250 KX	'87→'98	520	30300	16204	17206	
250 KX	'99→'08	520	27500	16204	17206	
250 KXF	'04→'05	520	24304	16204	17206	
250 KXF	'06→'18	520	24305	16204	17206	
250 KXF	'06→'18	520		16206	17206	17206
250 KXF E	'04		520	24304	16204	17206
250 KSF	'87→'02	520	24303	16310		
450 KXF	'06→'10	520	27502	16206	17206	17206
450 KXF	'11→'18	520	27502	16204	17206	
450 KXF	'11→'18	520	27502	16206	17206	17206
500 KX	'83→'86	520	24302	16204	17206	
500 KX	'87→'02	520	30300	16204	17206	
500 KX	'87→'02	520	30300	16206	17206	
KTM						
50 EXC	'96	428	94202		60103	
50 SX	'06→'08	415	94122		72103	
50 SX # 420	'06→'08	420	94123		72104	
50 SX	'09→'13	415	94124		72105	
50 SX MINI	'12→'13	415	94124		72105	
50 SX	'14→'18	415	94124		72106	
50 SX MINI	'14→'18	415	94124		72106	
60 SX	'98→'00	420	94120		72101	
65 SX	'01→'18	420	94120		72101	
80 MX Small wheels	'86→'90	428	73100			
80 MX Big wheels	'86→'90	428	73100			
85 SX Big wheels	'03→'18	428	94202		72102	
85 SX Small wheels	'03→'18	428	94202		72102	
105 SX	'04→'06	428	94202		72102	
125 GS	'79	520	73200			
125 GS	'80→'83	520	73301			
125 GS	'84→'90	520	73301	71303	72303	
125 GS XC	'85→'86	520	73301	71303	72303	
125 GS	'91→'97	520	73301	71304	72304	72304
125 EXC	'95→'16	520	73301	71304	72304	72304
125 EXE	'00	520	73301	71304	72304	
125 EGS	'99	520	73301	71304	72304	72304
125 LC2	'96→'99	520	73202	71304	72304	
125 MC	'80→'83	520	73301		72200	
125 MX # 520	'84→'86	520	73301	71303	72303	
125 MX	'87→'90	520	73301	71303	72303	
125 MX	'91→'93	520	73301	71304	72304	72304
150-300 EXC TPI/XC TPI 2T	'20→'21	520	73301	71304	72304	72304
125 SX	'94→'18	520	73301	71304	72304	72304
144 SX	'08	520	73301	71304	72304	72304



OFF-ROAD

Modello	Anno	Passo	Pignone codice (vedi listino singolo per range) -/+ (con scarico)	Corona acc. codice (vedi listino singolo per range) -/SLK + (con scarico)	Corona all. codice (vedi listino singolo per range) -/+ (con scarico)	Corona all. col. codice (vedi listino singolo per range) PB PR PK PO R
150 SX	'09→'11	520	73301	71304	72304	72304
150 SX	'12→'18	520	73301	71304	72304	72304
200 EXC	'98→'16	520	73301	71304	72304	72304
200 SX	'03→'04	520	73301	71304	72304	72304
240 GS	'78→'80	520	73200			
250 GS	'81→'83	520	73301			
250 GS	'84→'89	520	73301		72303	
250 GS	'90→'94	520	73301	71304	72304	72304
250 EXC	'95→'98	520	73301	71304	72304	72304
250 EXC EGS	'99→'03	520	73301	71304	72304	72304
250 EXC	'04→'17	520	73301	71304	72304	72304
250 EXC TPI	'18	520	73301	71304	72304	72304
250 EXC-F	'02→'18	520	73301	71304	72304	72304
250 Free Ride	'14→'16	520	73301	-	72306	
250 MC	'78→'80	520	73200			
240 MC	'81→'82	520	73301		72301	
240 MX	'84→'87	520	73301	71303	72303	
240 PLMC	'83	520	73301			
250 MX	'88→'89	520	73301	71303	72303	
250 MX	'90→'92	520	73301	71304	72304	72304
250 SX	'93→'18	520	73301	71304	72304	72304
250 SX-F	'05→'18	520	73301	71304	72304	72304
250 XC	'07→'16	520	73301	71304	72304	72304
250 XC-F	'07→'16	520	73301	71304	72304	72304
300 GS	'85→'86	520	73301	71303	72303	
300 GS	'90→'17	520	73301	71304	72304	72304
300 EXC	'00→'17	520	73301	71304	72304	72304
300 EXC TPI	'18	520	73301	71304	72304	72304
300 EXC E	'08	520	73301	71304	72304	72304
300 MX	'90→'92	520	73301	71304	72304	72304
300 SX	'93→'04	520	73301	71304	72304	72304
300 XC	'08→'16	520	73301	71304	72304	72304
350 Free Ride	'12→'16	520	73301	-	72306	
350 GS	'87→'89	520	73301	71303	72303	
350 SX-F	'10→'18	520	73301	71304	72304	72304
350 EXC-F	'11→'18	520	73301	71304	72304	72304
350 XC-F	'12→'16	520	73301	71304	72304	72304
360 EXC	'96→'98	520	73301	71304	72304	72304
360 SX	'96→'98	520	73301	71304	72304	72304
380 EXC	'00	520	73301	71304	72304	72304
380 SX	'00	520	73301	71304	72304	72304
390 GS	'81→'82	520	73301			
390 RC	'15→'17	520	73305	71202		
400 EXC Racing	'00→'06	520	73301	71304	72304	72304
400 EXC	'09→'10	520	73301	71304	72304	72304
400 LC4	'93→'00	520	73303	71304	72304	72304
400 LC4 E	'98→'99	520	73303	71304	72304	
400 SC	'99	520	73303	71304	72304	72304
400 SX Racing	'00→'02	520	73301	71304	72304	72304
420 GS	'83	520	73301			
420 GS	'84	520	73301	71303	72303	
440 SX	'94	520	73301	71304	72304	72304
450 EXC-F	'03→'18	520	73301	71304	72304	72304
450 EXC-R	'08	520	73301	71304	72304	72304
450 Rally Factory	'11→'15	520	73303	71304		
450 SMR	'05→'10	520	73301		72304	
450 SMR	'12→'14	520	73301	71304	72304	72304
450 SX	'03	520	73301	71304	72304	72304



OFF-ROAD

Modello	Anno	Passo	Pignone codice (vedi listino singolo per range) -/+ (con scarico)	Corona acc. codice (vedi listino singolo per range) -/SLK + (con scarico)	Corona all. codice (vedi listino singolo per range) -/+ (con scarico)	Corona all. col. codice (vedi listino singolo per range) PB PR PK PO R
450 SX- F	'04→'18	520	73301	71304	72304	72304
450 SX ATV	'08→'13	520	73301	71305		
450 XC ATV	'08→'10	520	73301	71305		
450 XC- F	'08→'16	520	73301	71304	72304	72304
495 MC	'82→'83	520	73301		72301	
495 MX	'84	520	73301	71303	72303	
500 EXC-F	'11→'18	520	73301	71304	72304	72304
500 MX	'85→'90	520	73301	71303	72303	
500 SX	'95→'98	520	73301	71304	72304	72304
505 SX F	'08	520	73301	71304	72304	72304
505 SX ATV	'08→'12	520	73301	71305		
520 EXC	'00→'02	520	73301	71304	72304	72304
520 SX Racing	'00→'02	520	73301	71304	72304	72304
525 SX	'03→'06	520	73301	71304	72304	72304
525 EXC	'03→'06	520	73301	71304	72304	72304
525 XC ATV	'08→'12	520	73301			
530 EXC	'09	520	73301	71304	72304	72304
530 EXC-R	'08	520	73301	71304	72304	72304
540 GS	'98→'99	520	73303	71304	72304	72304
560 SMR	'06→'08	520	73301	71304	72304	
600 LC4 Enduro	'88→'89	520	73301	71303		
600 LC4 Enduro	'90	520	73303	71500		
600 LC4 Enduro	'91→'93	520	73303	71304	72304	72304
600 Incas		520	73301	71500		
600 LC4 MX	'89	520	73301	71303	72303	
600 LC4 MX	'90→'92	520	73303	71500		
620 DUKE	'94→'99	520	73303	71304	72304	
620 EGS-E Adventurer	'98	520	73303	71304	72304	
620 LC4 Enduro	'90→'99	520	73303	71304	72304	72304
620 LC4-E Enduro	'00→'02	520	73303	71304	72304	
620 MX LC4	'94	520	73303	71304	72304	72304
620 LC4 SX	'95→'98	520	73303	71304	72304	72304
620 LSE	'97→'98	520	73303	71304	72304	
625 SXC	'03→'07	520	73303	71304	72304	72304
690 R Enduro ABS	'18→'20	520	73303	71304		

MAICO

250/500 GS/MC	'83	520	73301			
250/500 GME	'86→'87	520	73301			
500 GME	'86	520	73301			
500 GS/MC	'83	520	73301			

MONTESA

250 4 RT	'05→'06	520	79304		93320	
310/311 Cota		520	79302		78303	
314 R	'94→'96	520	20303		78303	
315R	'97→'03	520	20303		78303	
349 Cota		520	79302			

SCORPA

125 SY F	'03→'04	428	28200		93212	
125 TY-S F	'04→'05	428	21200		93212	
175 SY F	'03→'04	428	28200		93212	
250 Easy	'96→'99	520	61201			
250 SY Racing	'04→'07	520	21203		93319	
295 Works		520	61201			



OFF-ROAD

Modello	Anno	Passo	Pignone codice (vedi listino singolo per range) -/+ (con scarico)	Corona acc. codice (vedi listino singolo per range) -/SLK + (con scarico)	Corona all. codice (vedi listino singolo per range) -/+ (con scarico)	Corona all. col. codice (vedi listino singolo per range) PB PR PK PO R
SHERCO						
50 SE-R	'03→'18	428	94118	59104	60104	
50 SM	'03→'18	428	94118	59104	60104	
80 0,8	'05	520	94306		93303	
125 City Corp	'04→'09	428	21200	59104		
125 City Corp SM	'07→'09	428	21200	59104		
125 1.25	'03→'05	520	94306		93303	
125 1.25	'06→'11	520	94306		93320	
SE-R 125	'18	520	43303		15206	
200 2.0	'03	520	94306		93303	
250 1994	'01	520	94306		93303	
250 2.5	'02→'16	520	94306		93320	
250 SE/SER	'14→'18	520	43304	14206	15206	
250 SEF i	'09→'18	520	43302	14206	15206	
290 2.9	'03→'14	520	94306		93320	
300 3.0	'15→'16	520	94306		93320	
300 SE/SER	'14→'18	520	43304	14206	15206	
300 SE/SEF Enduro Factory	'21→'21	520	43305	14206	15206	15206
300 SEF i	'10→'11	520	43302	14206	15206	
300 SEF i	'12→'18	520	43303	14206	15206	
320 3,2	'05→'11	520	94306		93320	
450 SEF i	'04→'12	520	43400	14206	15206	
450 SEF i	'16→'18	520	43304	14206	15206	
500 SCF Cross Country/ Enduro Factory	'19→'21	520	43304	14206	15206	15206
510 SEF i	'06→'11	520	43400	14206	15206	
SUZUKI						
50 RM	'81→'82	420	27100	14100		
50 RMX	'96→'03	420	22103	14109		
65 RM	'03→'05	420	30100		17107	
80 RM	'79→'81	428	22102			
80 RM Z	'82	428	28200			
80 RM D Small wheels	'83	428	28200		15104	
80 RM Small wheels	'84→'85	428	28200			
80 RM Small wheels	'86→'88	420	22103			
80 RM Small wheels	'86→'88	428	28200			
80 RM Small wheels	'89→'01	428	28200		15104	
80 RM Big wheels	'83→'86	428	28200			
80 RM Big wheels	'96→'01	428	28200		15104	
85 RM Small wheels	'02→'13	428	28200		15104	
85 RM Big wheels	'02→'18	428	28200		15104	
100 RM	'03	420	30100		17104	
100 RM #428	'03	428	24100		17105	
125 RM	'82→'86	520	22202	14203	15203	15203
125 RM	'87→'11	520	22203	14203	15203	15203
250 RM	'79→'80	520	22302	14206	15206	
250 RM X	'81	520	22302	14203	15203	15203
250 RM Z	'82→'83	520	22303	14203	15203	15203
250 RM	'84→'86	520	22303	14501		
250 RM	'87→'08	520	22303	14203	15203	15203
250 RM-Z	'04→'06	520	24304	16206	17206	
250 RM-Z	'07→'12	520	22203	14203	15203	
250 RM-Z	'13→'15	520	22309	14203	15203	15203
250 RM-Z	'16→'18	520	22311	14203	15203	15203
250 RMX R, K1-K2	'89→'02	520	22303	14203	15203	15203
450 RM-Z K8-L4	'05→'16	520	22406	14203	15203	15203



OFF-ROAD

Modello	Anno	Passo	Pignone codice (vedi listino singolo per range) -/+ (con scarico)	Corona acc. codice (vedi listino singolo per range) -/SLK + (con scarico)	Corona all. codice (vedi listino singolo per range) -/+ (con scarico)	Corona all. col. codice (vedi listino singolo per range) PB PR PK PO R
450 RM-Z	'15→'18	520	22408	14203	15203	15203
450 RMX-Z	'10→'17	520	22406	14203	15203	
465 RM X	'81	520	22302			

SWM

300 RS - R	'15→'16	520		14206	15206	15206
500 RS - R	'15→'16	520		14206	15206	15206

TM

80/85 Big wh. (CHASSIS 125 CC)	'01→'05	520	94214		93314	
80/85 Big wheels	'01→'05	428	94117		93106	
125 EN	'97→'99	520	94214		93314	
125 EN	'00→'16	520	94215		93314	
125 MX	'03→'6	520	94215		93314	
144 EN	'07→'13	520	94215		93314	
144 MX	'07→'16	520	94215		93314	
250 EN/MX	'00→'03	520	94312		93314	
250 EN	'05→'16	520	94312		93314	
250 MX	'05→'13	520	94312		93314	
250 EN F/MX F 4T	'02	520	94312		93314	
250 EN F 4T	'03→'10	520	94312		93314	
250 EN FI 4T	'11→'16	520	94317		93314	
250 MX F 4T	'05→'09	520	94312		93314	
250 MX FI 4T	'10→'11	520	94317			
250 MX FI 4T	'12→'16	520	94317		93314	
300 EN/MX	'01→'02	520	94312		93314	
300 EN	'05→'16	520	94312		93314	
300 MX	'03→'16	520	94312		93314	
400 EN F/MX F 4T	'02→'04	520	94312		93314	
450 EN F/FI 4T	'05→'16	520	94312		93314	
450 MX F 4T	'05→'14	520	94312		93314	
530 EN F 4T	'05→'16	520	94312		93314	

VOR

400 Enduro	'01→'02	520	94314		93209	
501 Enduro	'99	520	64302		93209	
501 Enduro	'00→'01	520	94314		93209	
530 SM	'02	520	94314			
530 Enduro	'02	520	94314		93209	
530 MX	'02	520	94314		93209	

YAMAHA

50 YZ	'81→'83	420	27100			
60 YZ	'84	420	30100			
65 YZ	'18→'21	420	21108		13116	
80 YZ	'80	428	22102		13208	
80 YZ	'81→'84	428	28200			
80 YZ	'85→'92	428	28200		13108	
80 YZ	'93→'01	428	28200		15104	
80 YZ Big wheels	'94→'01	428	28200		15104	
85 YZ Small wheels	'02→'12	428	21202		15104	
85 YZ Big wheels	'02→'18	428	21202		15104	
125 WR	'98	520	21203	12508	13508	
125 WR	'99→'03	520	21203	12323	13323	
125 WR R	'09→'16	428	21208	12207		
125 WR X	'09→'16	428	21208	12207		
125 YZ	'77→'79	520	30200			



OFF-ROAD

Modello	Anno	Passo	Pignone codice (vedi listino singolo per range) -/+ (con scarico)	Corona acc. codice (vedi listino singolo per range) -/SLK + (con scarico)	Corona all. codice (vedi listino singolo per range) -/+ (con scarico)	Corona all. col. codice (vedi listino singolo per range) PB PR PK PO R
125 YZ	'80→'86	520	30200	12508	13508	
125 YZ	'87→'98	520	21203	12508	13508	
125 YZ	'99→'04	520	21203	12323	13323	13323
125 YZ	'05→'18	520	21309	12323	13323	13323
125 YZF-R	'08→'18	428	21208	12227		
200 WR R	'92→'94	520	21203	12508	13508	
250 WR	'89→'99	520	30300	12508	13508	
250 WR	'00→'03	520	27500	12323	13323	13323
250 WR F	'01→'18	520	21309	12323	13323	13323
250 WR R	'08→'14	520	21309	12323	11304	
250 YZ	'80→'98	520	30300	12508	13508	
250 YZ	'99→'18	520	27500	12323	13323	13323
250 YZ F	'01→'18	520	21309	12323	13323	13323
250 YZ FX	'15→'17	520	21309	12323	13323	13323
250 YZ X/250 WR	'16→'17	520	27500	12323	13323	13323
400 WR F	'98	520	27500	12508	13508	
400 WR F	'99→'00	520	27500	12323	13323	13323
400 YZ F	'98	520	27500		13508	
400 YZ F	'99	520	27500	12323	13323	13323
426 WR F	'00→'02	520	27500	12323	13323	
426 YZ F	'00→'02	520	27500	12323	13323	13323
450 WR F	'03→'18	520	27500	12323	13323	13323
450 YFZ	'03→'13	520	27500	12407	13407	
450 YFZ	'09→'18	520	21403	12407	13407	
450 YFZ	'03→'18	520	27500	12323	13323	
450 YZ FX	'16→'17	520	27500	12323	13323	
465 YZ	'80	520	30300	12500	13500	
465 YZ	'81	520	30300	12508	13508	
490 YZ	'83→'84	520	30300	12500		
490 YZ	'82→'90	520	30300	12508	13508	

PIGNONI E CORONE





PIGNONI / SPROCKETS

Code	€	Code	€	Code	€
100300-11	15,44	20202-11	12,78	20315-16 PS	18,34
100300-12	16,14	20202-12	13,02	20317-13	14,18
100300-13	16,77	20202-13	13,20	20317-14	14,46
100500-13	14,35	20203-12	12,85	20320+13	18,34
100500-14	14,91	20203-13	13,20	20320+14	18,62
112300-12	14,98	20203-14	13,65	20320-12	13,20
112300-14	16,24	20204-13	13,41	20320-13	13,65
112300-15	16,94	20205-12	14,35	20320-14	13,93
166300-15	21,00	20206+13	15,26	20324+13	19,08
166300-16	21,98	20206-12	11,03	20324-13	14,28
166400-14	15,61	20206-13	11,41	20324-14	14,35
166600-16	25,45	20206-14	11,62	20400-15	14,74
166600-17	26,88	20207-14	12,53	20400-16	15,61
166600NR-16	25,45	20207-15	13,02	20400-17	16,14
166600NR-17	26,88	20207-16	13,51	20401-16	16,84
166601-17	27,58	20207-17	14,04	20402-16	21,46
166800-15	20,41	20207-18	14,53	20403-15	18,80
166800-16	21,91	20209-14	4,94	20404-16	20,02
166800-17	22,96	20209-15	5,43	20405-13	20,13
166800NR-17	22,96	20209-16	5,85	20405-14	21,28
166801-15	20,83	20209-17	6,51	20405-15	22,54
166801-16	22,26	20209-18	7,21	20405-16	24,12
166801-17	23,42	20210+13	15,26	20405NR-15	22,54
166802-15	16,87	20210+14	15,47	20407-13	20,13
166802-16	18,03	20210-13	11,41	20407-14	21,28
166802-17	18,90	20210-14	11,62	20407-15	22,54
181300-13	16,31	20211-14	6,09	20407NR-15	22,54
187500-17	15,86	20211-15	6,20	20408-13 PS	20,13
187501-15	13,41	20212-14	7,11	20408-14 PS	21,28
20100-14	6,09	20212-15	7,39	20500-13	13,93
20100-15	6,20	20300-09	12,78	20500-14	14,28
20100-16	6,48	20300-10	13,02	20500-15	14,74
20101-13	5,15	20302-15	12,95	20500-16	15,44
20101-14	5,53	20303-09	10,99	20502-17	21,28
20101-15	6,16	20303-10	11,27	20502-18	22,26
20101-16	6,58	20304-13	12,25	20503-15	17,40
20103-14	6,09	20305-12	13,20	20504-13	19,95
20104-12	5,74	20305-13	13,65	20504-14	20,93
20104-13	5,95	20305-14	13,93	20504-15	22,16
20104-14	6,09	20305-15	14,28	20504-16	23,77
20104-15	6,20	20306-13	13,93	20505-16	18,10
20104-16	6,48	20306-14	14,28	20506-15	18,80
20105+15	9,94	20306-15	14,74	20506-16	20,02
20105-13	5,95	20308-13	14,74	20507-14	18,10
20105-14	6,09	20308-14	15,33	20507-15	18,80
20105-15	6,20	20309-14	15,51	20507-16	20,02
20107-14	6,16	20310-13	14,91	20507-17	21,11
20107-15	6,48	20310-14	15,51	20507NR-15	17,96
20108-14	7,11	20311+13	16,21	20508-14	15,61
20108-15	7,39	20311+14	16,66	20508-15	16,24
20108-16	7,67	20311+15	17,08	20509-14	15,61
20111-14 PS	12,25	20311-12	11,83	20509-15	16,24
20111-16 PS	13,02	20311-13	12,25	20509-16	17,19
20112-13	6,09	20311-14	12,78	20510-13	14,35
20113-11	5,74	20311-15	13,23	20510-14	14,91
20114-13	6,09	20311-16	13,86	20510-15	15,44
20200-11	5,53	20313-12	11,97	20511-14	21,18
20200-12	5,71	20313-13	12,25	20511-15	22,44
20200-13	5,81	20314-14	14,46	20513-14	21,28
20200-14	5,53	20314-15	14,98	20513-15	22,54
20200-15	6,09	20314-16	15,96	20514-16	20,02
20200-16	6,58	20315-14 PS	16,59	20515-14	20,93
20200-17	6,93	20315-15 PS	17,40	20515-15	22,16



PIGNONI / SPROCKETS

Code	€	Code	€	Code	€
20515NR-15	22,16	21202-15	5,88	21504NR-15	20,76
20516-13	20,13	21202-16	6,06	21505-15	15,89
20516-14	21,18	21202-17	6,51	21506-15	21,63
20516-15	22,44	21202-18	7,21	21506-16	23,14
20516-16	23,94	21202-19	7,49	21510-14	15,61
20517-13	17,47	21202-20	10,15	21510-15	16,24
20517-14	18,27	21203+12	15,09	21511-14	16,84
20517-15	19,32	21203+13	15,33	21511-15	17,57
20600-15	22,96	21203-10	10,33	21511-16	18,62
20601-15	27,13	21203-11	10,78	21512-15	17,57
20602-14	19,25	21203-12	10,96	21512-16	18,62
20602-15	20,23	21203-13	11,10	21512NR-16	18,62
20602-16	21,63	21203-14	11,41	21600-17	16,14
20602-17	22,61	21207-13	5,08	21601-14	13,93
20602-18	23,87	21207-14	5,22	21601-15	14,28
20603-15	22,16	21208-13	5,01	21601-16	14,98
20603-16	23,77	21208-14	5,04	21601-17	15,51
20603-17	24,99	21208-15	5,57	21602-15	17,57
20603NR-16	23,77	21209-14	6,20	21602-16	18,62
20604-16	22,33	21300-12	14,00	21602-17	19,32
20605-16	22,61	21300-13	14,35	21602NR-16	18,62
20606-15	19,95	21300-14	14,91	21602NR-17	19,32
20606-16	21,11	21301-13	12,25	21602OEM-16	29,54
20606-17	22,16	21301-14	12,50	21603-13	16,24
20607-15	20,23	21301-15	12,95	21603-14	16,84
20608-14	20,93	21301-16	13,48	21603-15	17,57
20608-15	22,16	21301-17	13,83	21603-16	18,62
20608-16	23,77	21304-17	8,68	21603-17	19,32
20608-17	24,99	21304-18	9,00	21606-14	16,66
20609-17	22,61	21304-19	9,28	21606-15	17,57
20611-15	20,23	21305-14	5,22	21606-16	18,62
20611NR-15	20,23	21305-15	6,48	21606-17	19,32
20612-14	20,93	21307-13	16,24	21607-15	17,57
20612-15	22,16	21307-14	16,94	21607-16	18,62
20612-16	23,77	21308-13	12,25	21607NR-16	18,62
20612NR-15	22,16	21308-14	12,50	21607OEM-16	28,42
20612NR-16	23,77	21309-12	10,96	21608-13	13,20
20613-13	19,95	21309-13	11,10	21608-14	13,65
20613-14	20,93	21309-14	11,41	21608-15	14,00
20613-15	22,16	21311-14	9,84	21608-16	14,63
20613-16	23,77	21311-15	10,12	21608-17	14,63
20613-17	24,99	21312-14	17,40	21611-15	17,57
20614-17	22,16	21400-17	9,07	21611-16	18,62
20615-15	22,16	21400-18	9,35	21801-14	16,84
20615-16	23,77	21400-19	9,63	21801-15	17,57
20617-15	22,16	21400-20	12,71	21801-16	18,62
20617-16	23,77	21401-14	15,51	21801-17	19,32
20617-17	24,99	21401-15	16,03	21801-18	20,13
20617NR-16	23,77	21401-16	16,84	21801NR-16	18,62
20617NR-17	24,99	21403-13	13,20	21801NR-17	19,32
20618-16	21,63	21403-14	13,65	21801NR-18	20,13
20801-18	23,24	21403-15	14,00	21802-15	20,65
20802-18	23,87	21500-16	16,03	21802-16	21,91
21105-14 PS	4,90	21501-15	17,75	21802-17	22,75
21108-14	6,83	21501-16	18,80	21803-17	22,75
21200-14	5,18	21501-17	19,78	21804-14	16,84
21200-15	5,43	21502-13	13,93	21804-15	17,57
21200-16	5,85	21502-14	14,28	21804-16	18,62
21200-17	6,93	21502-15	14,74	21804-17	19,32
21202+14	9,94	21502-16	15,44	21805-15	17,57
21202+16	10,47	21504-14	19,71	21805-16	18,62
21202-13	5,50	21504-15	20,76	21805-17	19,32
21202-14	5,53	21504-16	22,16	22100-12	5,74



PIGNONI / SPROCKETS

Code	€	Code	€	Code	€
22100-13	5,95	22407-15	18,10	24305-12	12,53
22100-15	6,20	22408+13	19,95	24305-13	13,16
22100-16	6,48	22408+14	20,48	24305-14	13,69
22101-12	5,74	22408-13	15,16	24400-14	16,24
22102-14	6,20	22408-14	15,79	24400-15	16,94
22103-12	6,34	22501-15	14,74	24401-15	14,74
22103-13	6,48	22502-14	14,28	24500-14	14,28
22103-14	6,62	22502-16	15,61	24500-15	14,74
22104-10	12,32	22503-15	14,74	24500-16	15,61
22200-13	6,09	22503-16	15,44	24500-17	16,14
22200-14	5,53	22503-17	16,03	24501-14	14,91
22200-15	6,48	22505-15	15,44	24501-15	15,44
22201-14	8,61	22505-16	16,24	24501-16	16,24
22201-15	8,89	22600-14	15,61	24501-17	16,77
22201-16	9,21	22600-15	16,24	24502-13	14,35
22202-12	13,02	22600-16	17,19	24502-14	14,91
22203+11	15,72	22601-15	26,39	24502-15	15,44
22203+12	15,96	22602-14	15,61	24502-16	16,24
22203+13	16,35	22602-15	16,24	24504-14	14,28
22203-12	11,83	22800-15	17,33	24504-16	15,61
22203-13	12,22	22800-16	18,34	24504-17	16,14
22203-14	12,46	22801-15	18,73	24505-13	17,40
22205-13	7,07	22801-16	19,95	24505-14	18,17
22205-14	7,21	22801-17	20,83	24505-15	19,08
22205-15	7,53	22802-15	18,73	24506-14	19,60
22302-13	14,18	22802-16	19,95	24506-15	20,58
22302-14	14,46	22802-17	20,83	24506-16	21,98
22303+12	15,96	22900-15	14,74	24507-13	18,62
22303+13	16,35	22900-16	15,61	24507-14	19,60
22303+14	16,59	22900-17	16,14	24507-15	20,58
22303+15	16,98	22900-18	16,84	24508-14	19,88
22303-12	12,92	22900NR-17	16,14	24508-15	20,93
22303-13	13,37	22901-15	15,44	24509-13	18,10
22303-14	13,93	22901-16	16,24	24509-14	18,97
22303-15	14,39	22901-17	16,77	24509-15	20,02
22304-14	12,50	22902-15	15,44	24509-16	21,46
22305-13	13,65	22902-16	16,24	24510-15	20,58
22305-14	13,93	22902-17	16,77	24511-14	13,93
22305-15	14,28	24100-13	6,41	24511-15	14,28
22310-14	15,51	24100-14	6,48	24511-16	14,98
22311+13	19,60	24101-14 PS	6,09	24600-15	28,70
22311-13	14,81	24101-15	6,20	24601-15	14,74
22401-13	13,83	24102-14 PS	6,48	24601-16	15,61
22401-14	14,11	24200-13	6,09	24601-17	16,14
22401-15	14,46	24200-14	6,20	24601-18	16,84
22401-16	15,16	24200-15	6,48	24601NR-16	15,61
22403-15	14,74	24200-16	6,69	24601NR-17	16,14
22404-14	13,20	24201+12	15,09	24601NR-18	16,84
22404-15	13,65	24201+13	15,33	24602-15	20,23
22405+13	18,34	24201-11	10,78	24603-14	21,98
22405+14	18,62	24201-12	10,96	24603-15	23,24
22405+15	19,08	24201-13	11,10	24603NR-15	23,24
22405-13	13,65	24203-14	6,48	24800-15	21,81
22405-14	13,93	24300-14	12,50	24801-15	25,45
22405-15	14,28	24302-14	14,91	24803-15	32,66
22406+13	17,22	24302-15	15,44	24805-17	27,69
22406+14	17,68	24303-12	14,74	24806-17	32,45
22406+15	18,17	24304+13	17,40	24900-16	20,02
22406-13	12,99	24304+14	17,75	24900-17	21,11
22406-14	13,55	24304-13	12,60	24902-18	21,28
22406-15	14,00	24304-14	12,95	25202-17 PS	25,80
22407-13	16,49	24305+13	17,36	26200-13	6,09
22407-14	17,40	24305+14	17,85	26200-14	6,20



PIGNONI / SPROCKETS

Code	€	Code	€	Code	€
26200-15	6,48	28401-18	15,33	37600-15	25,73
26200-16	6,69	28401NR-15	13,65	37600-16	27,58
26200-17	6,93	28401NR-16	14,28	37600-17	29,37
27100-09	5,22	28401NR-17	14,81	37600NR-15	25,73
27100-10	5,46	28401OEM-15	25,03	37600NR-16	27,58
27100-11	5,67	28401OEM-16	25,52	37600NR-17	29,37
27100-12	5,74	28402-13	14,35	37601-17	35,39
27100-13	5,95	28402-14	14,91	37601-18	37,87
27100-14	6,09	28402-15	15,44	40300-09	10,99
27100-15	6,20	28402-16	16,24	40300-10	11,27
27100-16	6,48	28402-17	16,77	40300-11	11,80
27100-17	6,69	28402-18	17,57	40300-12	11,97
27500+13	14,95	28403-15	15,44	43302-13	15,16
27500+14	15,26	28403-16	16,24	43303-13	22,58
27500+15	15,65	28403-17	16,77	43304-13	20,97
27500-12	11,97	28404-13	14,46	43304-14	21,70
27500-13	10,78	28404-14	14,74	43304-15	22,65
27500-14	11,03	28404-15	15,12	43305-13	17,43
27500-15	11,41	28404-16	15,86	43305-14	18,06
27500-16	11,90	28404-17	16,45	43400-13	16,77
27500-17	12,22	28405-15	15,61	43400-14	17,47
27500NR-14	11,03	28405-16	16,42	46200-14	6,20
27500NR-15	11,41	30100+13	9,70	46202-12	14,18
27500NR-16	11,90	30100+14	9,84	46202-13	14,46
27501-13	12,25	30100-12	5,74	46203-12	14,46
27501-14	12,50	30100-13	4,66	46203-13	14,98
27501-15	12,95	30100-14	4,97	46203-14	15,61
27502+13	15,33	30100-15	5,46	46203-15	16,24
27502+14	15,65	30100-16	6,48	46205-16	14,67
27502-13	11,10	30200-11	12,25	46205-18	15,65
27502-14	11,41	30200-12	12,43	46600-15	18,80
28200+13	9,84	30200-13	12,60	46601-15	14,74
28200+14	9,94	30200-14	12,95	46602-14	18,45
28200-10	5,67	30300+12	15,09	46602-15	19,50
28200-11	5,88	30300+13	15,33	46603-15	24,47
28200-12	5,95	30300+14	15,65	46604-15	26,64
28200-13	6,09	30300+15	15,96	49100-12	6,90
28200-14	6,20	30300-10	11,73	49100-13	7,21
28200-15	6,48	30300-11	12,25	49100-14	7,42
28200-16	6,69	30300-12	10,96	49100-15	7,63
28200-17	6,93	30300-13	11,10	49102-11	4,69
28201-13	6,09	30300-14	11,41	49102-12	4,83
28201-14	6,20	30300-15	11,83	49102-13	5,15
28201-15	6,48	30300-16	12,29	49102-14	5,81
28201-16	6,69	30300-17	14,28	49102-15	6,06
28201-17	6,93	30300-18	14,63	49200-14	5,53
28400-13	13,76	30301-15	14,74	52400-14	16,59
28400-14	14,28	30301-16	15,61	52500-15	20,02
28400-15	14,74	30301-17	16,14	52600-15	24,40
28400-16	15,61	33200-14	6,20	52600-16	26,15
28400-17	16,14	33200-15	6,48	52602-15	19,32
28400-18	16,84	33201-15	5,78	52604-14	28,07
28400NR-14	14,28	33201-17	6,93	52604-15	28,91
28400NR-15	14,74	33600-13	18,55	52606-15	17,92
28400NR-16	15,61	33600-14	19,29	52607-15	20,58
28400NR-17	16,14	33600-15	19,92	52608-14	28,07
28400NR-18	16,84	33600-16	21,18	52608-15	28,91
28400OEM-15	26,95	37200-13	6,76	52610-14	28,07
28400OEM-16	27,48	37201-13	7,35	52610-15	28,91
28401-14	13,20	37400-13	16,03	52611-14	28,07
28401-15	13,65	37400-14	16,66	52611-15	28,91
28401-16	14,28	37400-15	17,40	52611-16	29,96
28401-17	14,81	37400-16	18,45	52612-14	28,60



PIGNONI / SPROCKETS

Code	€	Code	€	Code	€
52612-15	29,51	61800-15	21,81	76200-14	14,28
52613-14	21,28	61800-16	23,24	76200-15	14,74
52613-15	22,44	61800-17	24,57	76201-13	13,93
52614-14	21,28	61800NR-16	23,24	76201-14	14,28
52614-15	22,44	61800NR-17	24,57	76300-13	18,62
52614-16	23,87	61801-15	23,70	76300-14	19,60
52616-14	28,84	61801-16	25,45	76300-15	20,58
52616-15	29,79	61802-15	23,70	79302-10	14,00
52618-14	24,64	61802-16	25,45	79304-09	15,16
52618-15	26,08	64200-12	12,78	79304-10	16,14
52619-15	26,39	64200-13	13,23	85200-16	6,69
52800-15	21,56	64200-14	13,76	88600-16	14,28
52900-14	21,74	64201-12	13,16	88600-17	14,81
52900-15	23,07	64201-13	13,62	88600-18	15,33
52900NR-15	23,07	64300-12	15,09	88800-17	16,14
52901-14	20,93	64300-13	15,61	88800-18	16,84
52901-15	22,16	64302-12	16,14	88800-19	17,47
52901-16	23,77	64302-13	16,77	88800NR-17	16,14
52902-14	20,93	64302-14	17,57	88800NR-18	16,84
52902-15	22,16	64302-15	18,27	88800NR-19	17,47
52902-16	23,77	64302-16	19,43	88801-16	16,24
55201-11	6,62	64302-17	20,30	88801-18	17,57
55300-11	16,24	64305-12	10,96	88802-18	19,29
55300-12	16,94	64305-13	11,10	88803-17	16,28
58102-12	7,81	64500+13	17,92	88900-16	16,80
58102-13	7,95	64500+14	18,55	88900-17	17,43
58102-14	8,23	64500+15	19,18	91800-17	25,62
58201-13	27,30	64500-12	13,23	91800-18	26,95
58202-13	27,58	64500-13	13,76	94100-11	10,33
58202-14	29,54	64500-14	14,32	94100-12	10,85
58500-14	25,73	64500-15	14,95	94100-13	11,27
58500-15	27,58	64500-16	15,96	94102-10	9,38
61201-10	11,27	70600-16	24,12	94107-12	10,54
61201-11	11,80	73100-13	7,07	94107-13	10,85
61201-13	12,25	73100-14	7,42	94107-14	11,06
61201-14	12,50	73200-13	18,10	94108-13	11,06
61201-15	12,95	73202-13	13,65	94108-14	11,48
61201-16	13,48	73203-13	13,83	94109-12	6,34
61201-17	13,83	73203-14	14,28	94109-13	6,48
61300-12	11,97	73301+12	15,54	94109-14	6,62
61300-13	12,25	73301+13	15,93	94109-15	6,90
61300-14	12,50	73301+14	16,35	94117-16	8,54
61301-13	14,98	73301+15	16,73	94118-11	5,74
61301-14	15,61	73301-11	13,65	94118-12	5,15
61301-15	16,24	73301-12	11,69	94118-13	5,92
61301-16	17,19	73301-13	11,97	94118-14	6,16
61301NR-15	16,24	73301-14	12,43	94119-11	5,39
61301NR-16	17,19	73301-15	12,85	94119-12	5,64
61302-15	18,27	73301-16	13,51	94119-13	6,20
61302-16	19,50	73301-17	13,93	94119-14	6,58
61302-17	20,41	73303-13	13,16	94119-15	6,79
61400-14	13,20	73303-14	13,65	94120+12	10,47
61500-16	20,30	73303-15	14,32	94120+13	10,68
61600-15	23,70	73303-16	15,12	94120+14	10,96
61600-16	25,45	73303-17	15,93	94120-12	7,32
61600-17	26,88	73303NR-15	14,32	94120-13	7,60
61600-18	28,46	73303NR-16	15,12	94120-14	6,90
61600NR-16	25,45	73304-16 PS	15,40	94121-11	7,25
61600NR-17	26,88	73304-17 PS	16,03	94121-12	7,46
61601-15	23,70	73304-18 PS	16,52	94121-13	7,74
61601-16	25,45	73305-13	17,64	94121-14	8,05
61602-19	30,14	73305-14	18,27	94122-10	9,91
61602-20	32,45	73305-15	18,87	94122-11	10,22



PIGNONI / SPROCKETS

Code	€	Code	€	Code	€
94123-10	7,18				
94123-11	7,46				
94124-10	9,70				
94124-11	10,01				
94202+12	10,47				
94202+13	10,57				
94202+14	10,75				
94202-11	6,90				
94202-12	6,90				
94202-13	6,93				
94202-14	7,04				
94214-12	16,14				
94214-13	16,77				
94215-12	14,25				
94215-13	14,77				
94301-10	13,30				
94301-11	14,00				
94304-09	13,58				
94305-10	11,27				
94305-11	11,80				
94305-12	11,97				
94306-09	12,78				
94306-10	13,13				
94312-13	14,18				
94313+12	18,38				
94313+13	19,01				
94313-12	14,25				
94313-13	14,77				
94313-14	15,51				
94314-14	27,48				
94317-13	12,60				
94503-16	19,78				
94602-21	27,69				
94603-14	15,96				
94603-15	16,42				
94604-14	15,79				
94604-15	16,31				
94605-16	30,42				
94605-17	32,45				
94802-21	20,65				
94803-19	17,47				
94804-16	21,18				
94806-24	46,48				
94807-15	17,12				
94900-15	15,61				
94900-16	16,42				
94902-17	21,11				
97200-09	14,18				
97200-10	14,74				
97200-11	15,51				



CORONE ACCIAIO STEEL REAR SPROCKETS

Code	€	Code	€	Code	€
10100-45	19,71	10223-43	15,58	10508-42	35,74
10101-38	15,37	10223-45	16,91	10508-43	38,85
10103-34	14,74	10223-47	21,70	10508-44	38,85
10103-38	15,37	10223-51	24,85	10508-45	40,67
10103-40	17,19	10226-51	24,85	10517-41	31,08
10103-42	17,92	10228-54	23,00	10521-40	31,29
10103-45	19,71	10228-58	31,64	10521-41	32,97
10103-47	20,51	10229-42	15,65	10602-38	27,13
10105-40	17,19	10230-45	20,79	10602-40	29,79
10106-35	19,50	10235-42	15,37	10602-42	31,08
10106-38	20,13	10236-42	16,42	10603-39	34,13
10106-41	22,65	10236-44	16,77	10603-40	34,13
10106-42	22,65	10236-45	17,19	10603-43	38,85
10109-33	13,23	10236-51	17,61	10603-46	40,67
10109-35	14,74	10237-47	24,12	10603-48	44,17
10110-46	21,70	10301-37	25,66	10604-41	57,93
10110-49	23,84	10301-44 PS	33,15	10605-39	34,13
10117-34	14,74	10301-47 PS	37,24	10605-40	34,13
10117-35	14,74	10310-44	33,15	10605-41	35,74
10122-36	10,68	10311-38	25,66	10605-42	35,74
10201-34	15,44	10316-38	25,66	10605-43	38,85
10201-35	15,44	10318-37	25,66	10605-44	38,85
10201-36	16,21	10318-38	25,66	10605-45	40,67
10201-37	16,21	10318-39	28,25	10605-46	40,67
10201-38	16,21	10318-40	28,25	10607-43	38,85
10201-39	18,03	10320-40	28,25	10608-40	29,79
10201-40	18,03	10320-45	34,48	10608-45	36,51
10201-41	18,76	10320-48	37,24	10608-46	36,51
10201-43	18,76	10337-36	27,69	10613-38	27,13
10201-47	21,70	10337-38	28,67	10613-41	31,08
10201-49	23,84	10338-36	27,69	10613-42	31,08
10201-51	24,85	10401-36	29,61	10613-43	35,18
10203-53	28,14	10401-38	30,98	10613-44	35,18
10205-53	28,14	10402-35	29,61	10613-45	36,51
10206-42	29,37	10402-36	29,61	10613-47	39,55
10212-43	33,15	10402-41	35,74	10616-40	37,24
10212-45	34,48	10404-40	34,13	10616-42	38,85
10212-47	37,24	10405-40	34,13	10616-43	41,97
10212-48	37,24	10405-43	38,85	10616-46	43,79
10212-49	38,71	10405-45	40,67	10617-40	32,83
10212-50	38,71	10405-46	40,67	10617-41	34,13
10212-51	41,76	10406-36	28,74	10617-42	34,13
10212-52	43,23	10409-44	35,18	10617-43	38,22
10214-33	22,40	10412-45	33,11	10617-44	38,22
10214-35	24,64	10501-42	29,37	10617-45	39,55
10214-40	28,25	10501-43	33,15	10617-46	39,55
10215-35	24,64	10501-45	34,48	10618RLK-41	46,76
10215-36	24,64	10501-46	34,48	10618RLK-42	46,76
10215-38	25,66	10501-47	37,24	10618RLK-43	50,96
10215-40	28,25	10501-48	37,24	10618RLK-44	50,96
10215-44	33,15	10501-50	38,71	10618RLK-45	52,43
10216-50	39,80	10502-47	39,55	10618RLK-46	52,43
10218-31	22,54	10502-48	39,55	10618RLK-47	53,52
10221-39	28,25	10502-49	41,16	10618RLK-48	53,52
10221-41	29,37	10503-33	26,71	10618RLK-49	54,99
10221-42	29,37	10503-35	29,61	10618RLK-50	54,99
10221-44	33,15	10504-36	29,02	10619-43	41,97
10221-45	34,48	10504-44	38,22	10627-38	28,67
10222-36 PS	16,21	10505-34	26,71	10627-39	28,25
10222-40 PS	18,03	10505-37	30,98	10627-41	29,37
10223-39	15,09	10508-39	34,13	10627-43	33,15
10223-41	15,26	10508-40	37,24	10628-43	35,18
10223-42	15,37	10508-41	35,74	10628-44	35,18



CORONE ACCIAIO STEEL REAR SPROCKETS

Code	€	Code	€	Code	€
10800-35	49,04	12304-39	28,25	12601-43	38,85
10801-44	41,97	12304-45	34,48	12601-44	38,85
10802-42	31,08	12305-45	34,48	12601-45	40,67
116100-62	31,29	12305-46	34,48	12601-46	40,67
12100-28	12,78	12305-47	37,24	12603-42	31,08
12100-32	13,23	12305-48	37,24	12603-43	35,18
12100-38	15,37	12313-47	21,70	12603-44	35,18
12100-42	17,92	12313-51	24,85	12604-46	34,48
12100-45	19,71	12313-55	28,14	12606-39	29,79
12100-48	20,51	12313-57	29,23	12606-42	31,08
12100-52	23,49	12323-39	28,25	12606-46	36,51
12101-30	12,95	12323-40	28,25	12607-48	44,17
12101-32	13,23	12323-41	29,37	12608-48	55,72
12101-35	14,74	12323-42	29,37	12801-38	34,13
12101-36	15,37	12323-44	33,15	12801-39	37,24
12101-37	15,37	12323-45	34,48	12801-40	37,24
12101-41	17,92	12323-47	37,24	12801-41	38,85
12101-48	20,51	12323-48	37,24	12801-42	38,85
12112-47	20,51	12323-49	38,71	12801-43	41,97
12113-47	20,51	12323-50	38,71	12801-46	43,79
12115-47	16,63	12323-51	41,76	12801-47	47,29
12115-60	25,03	12323-53	43,23	12801-48	47,29
12200-36	14,18	12325-45	21,60	12802-38	39,13
12200-39	15,79	12401-36	29,61	12802-43	49,04
12200-43	16,42	12401-39	34,13	12802-46	51,31
12200-45	16,70	12401-41	35,74	12802-47	55,72
12201-39	18,03	12401-43	38,85	12813-38	34,13
12202-45	20,79	12402-38	30,98	12813-39	37,24
12202-46	21,70	12403-44	38,85	12813-41	38,85
12202-49	23,84	12403-45	40,67	12813-42	38,85
12203-37	16,21	12407-36	24,64	12813-43	41,97
12203-45	20,79	12407-38	25,66	12813-44	41,97
12204-49	23,84	12407-39	28,25	12813-45	43,79
12204-51	24,85	12407-40	28,25	12813-46	43,79
12204-53	28,14	12407-43	33,15	12813-47	47,29
12207-53	23,24	12407-42	29,37	12813-48	47,29
12207-55	24,64	12500-43	33,15	12814-43	33,15
12207-57	24,85	12500-44	33,15	12814RLK-43	50,96
12208-50	23,84	12500-47	37,24	12814RLK-44	50,96
12208-51	24,85	12501-42	35,74	12814RLK-45	52,43
12208-52	24,85	12502-40	28,25	12814RLK-46	52,43
12208-54	28,14	12502-41	29,37	12814RLK-47	55,48
12214-32	21,49	12502-42	29,37	12815-41	34,13
12214-36	24,64	12503-42	35,74	12815-42	34,13
12216-46	21,70	12505-39	28,25	12815-43	38,22
12221-59	31,64	12505-40	28,25	12815-44	38,22
12222-49	23,84	12505-41	29,37	12815-45	39,55
12222-54	28,14	12505-44	33,15	12815-46	39,55
12224-49	23,84	12505-45	34,48	12815-47	42,60
12224-54	28,14	12505-46	34,48	12816-40	32,83
12226-44	20,79	12505-47	37,24	12816-41	34,13
12227-43	18,76	12505-48	37,24	12816-42	34,13
12227-47	18,87	12505-49	38,71	12816-43	38,22
12227-48	18,87	12507-44	38,85	12816-44	38,22
12227-52	19,81	12508-46	34,48	12816-47	41,90
12300-40	28,25	12508-48	37,24	12817RLK-39	45,61
12300-45	34,48	12508-49	38,71	12817RLK-40	45,61
12300-46	34,48	12508-50	38,71	12817RLK-41	46,76
12301-43	33,15	12508-52	43,23	12817RLK-42	46,76
12301-44	33,15	12512-55	28,14	12817RLK-43	50,96
12302-41	35,74	12600-33	26,71	12817RLK-44	50,96
12303-39	34,13	12601-38	30,98	14100-32	13,23
12304-37	25,66	12601-39	34,13	14100-37	15,37

CORONE ACCIAIO STEEL REAR SPROCKETS



Code	€	Code	€	Code	€
14100-38	15,37	14400-42	35,74	158200-48	15,47
14100-43	17,92	14400-44	38,85	16201-42	18,76
14100-46	20,51	14400-45	40,67	16201-46	21,70
14100-48	20,51	14401-37	25,66	16202-50	23,84
14100-51	23,49	14401-45	34,48	16203-48	21,70
14101-34 PS	15,44	14401-48	37,24	16203-50	23,84
14101-40	18,03	14404-42	31,08	16204-42	29,37
14101-42 PS	18,76	14404-44	35,18	16204-47	37,24
14101-43	18,76	14404-45	36,51	16204-48	37,24
14101-46	21,70	14404-46	36,51	16204-49	38,71
14102-28	12,78	14404-47	39,55	16204-50	38,71
14109-50	22,61	14404-48	39,55	16207-52	24,85
14110-22	17,15	14405-39	31,29	16209-44	20,79
14112-37	15,37	14405-46	37,52	16209-47	21,70
14200-44	20,79	14405-47	41,02	16212-56	16,38
14200-47	21,70	14412-36	24,64	16300-41	29,37
14200-50	23,84	14412-37	25,66	16302-40	28,25
14200-53	28,14	14412-38	25,66	16302-44	33,15
14201-41	18,76	14412-40	28,25	16310-43	33,15
14201-42	18,76	14500-40	34,13	16400-35	29,61
14201-43	18,76	14501-42	29,37	16400-41	35,74
14201-47	21,70	14501-47	37,24	16400-44	38,85
14201-48	21,70	14501-48	37,24	16400-45	40,67
14201-49	23,84	14503-38	30,98	16401-40	34,13
14201-50	23,84	14503-43	38,85	16401-42	35,74
14202-50	23,84	14503-46	40,67	16402-38	30,98
14203-39	28,25	14503-50	45,92	16402-40	34,13
14203-41	29,37	14506-41	31,08	16404-37	25,66
14203-43	33,15	14506-43	35,18	16404-42	29,37
14203-44	33,15	14507-44	35,18	16406-35	24,64
14203-47	37,24	14507-45	36,51	16406-36	24,64
14203-48	37,24	14507-46	36,51	16406-37	25,66
14203-49	38,71	14600-41	57,93	16406-38	25,66
14203-50	38,71	14600-42	62,55	164600-43	37,63
14203-51	41,76	14601-42	35,74	164600-44	38,85
14205-54	28,14	14601-43	38,85	164600-45	38,85
14205-59	31,64	14601-44	38,85	164601RLK-42	49,25
14206-41	29,37	14601-45	40,67	164601RLK-43	50,12
14206-43	33,15	14601-46	40,67	164601RLK-44	50,12
14206-44	33,15	14601-47	44,17	164601RLK-45	51,52
14206-45	34,48	14601-48	44,17	164601RLK-46	51,52
14206-46	34,48	14603-47	39,55	164800-42	34,13
14206-48	37,24	14604-41	34,13	164800-43	38,22
14206-49	38,71	14604-42	34,13	164800-44	38,22
14206-50	38,71	14604-43	38,22	164800-45	39,55
14207-50	23,84	14604-44	38,22	164800-46	39,55
14208-47	21,70	14604-45	39,55	164801RLK-43	50,96
14212-45	20,79	14604-47	42,60	164801RLK-44	50,96
14213-45	20,79	14604-48	42,60	164801RLK-45	52,43
14214-56	29,23	146100-48	20,51	164801RLK-46	52,43
14215-49	19,50	14901-42	45,08	164802-45	39,55
14215-51	24,85	14901-44	49,04	164803RLK-43	50,96
14216-57	29,23	14901-48	55,72	164803RLK-44	50,96
14303-46	34,48	14901-52	62,55	164803RLK-45	52,43
14304-42	29,37	14902-39	34,13	16500-38	28,67
14310-39	28,25	14902-42	35,74	16500-40	31,29
14310-40	28,25	14902-43	38,85	16500-41	32,41
14310-41	29,37	14902-44	38,85	16500-42	32,41
14310-42	29,37	14902-45	40,67	16500-43	36,16
14310-46	34,48	14902-48	44,17	16500-44	36,16
14312-41	29,37	14902-52	49,53	16500-46	37,52
14313-43	33,15	14911-41	35,74	16500-47	40,25
14400-33	26,71	158200-44	13,76	16501-43	37,73



CORONE ACCIAIO STEEL REAR SPROCKETS

Code	€	Code	€	Code	€
16502-39	34,13	35103-50	21,28	44203-43	33,15
16502-45	40,67	35103-51	21,39	44501-45	36,51
16504-40	28,25	35103-53	22,19	44601-46	40,67
16600-37	25,20	35104-47	22,96	44601-48	44,17
16600-38	25,66	35107-50	23,84	44602-41	31,08
16600-42	29,37	35200-38	34,55	44602-45	36,51
16600-43	33,15	35202-44	33,15	44800-40	34,13
16600-44	33,15	35204-45	34,48	47100-50	22,68
16600-46	34,48	35204-49	38,71	47100-53	23,66
16601-33	43,05	35206-40	37,24	47101-48	46,59
16601-34	45,08	35303-43	36,16	47102-52	23,49
16601-41	57,93	35303-46	37,52	47103-47	16,91
16602-47	44,17	35304-40	31,29	47103-48	17,12
16603-38	30,98	35304-42	32,41	47103-50	18,48
16603-39	34,13	35304-43	36,16	47103-52	19,67
16603-40	34,13	35304-44	36,16	47103-53	20,23
16603-41	35,74	35304-45	37,52	47103-60	25,52
16603-42	35,74	35304-46	37,52	47103-62	27,72
16603-43	38,85	35304-47	40,25	47200-48	18,03
16603-44	38,85	35304-49	41,76	47200-50	19,50
16603-45	40,67	35306-42	29,37	47200-51	24,85
16603-46	40,67	35800-40	32,83	47200-54	28,14
16603-48	44,17	35800-41	34,13	47200-56	29,23
16604-41	35,74	35800-42	34,13	47200-58	31,64
16604-42	35,74	35800-43	38,22	47200-60	31,64
16604-44	38,85	35800-45	39,55	47200-62	33,36
16604-45	40,67	35801-40	31,29	47201-50	23,84
16604-46	40,67	35801-44	36,16	47202-49	23,84
16605-38	27,13	35802-40	32,83	47203-62	35,77
16605-39	29,79	35802-41	34,13	47203-69	25,41
16605-40	29,79	35802-42	34,13	50600-38	30,98
16606-43	36,16	35802-43	38,22	50600-47	44,17
16606-45	37,52	35802-44	38,22	50601-38	25,66
16606-46	37,52	35802-46	39,55	50601-39	28,25
16606RLK-38	42,67	35803-43	38,22	50601-40	28,25
16606RLK-39	45,61	35804-45	39,55	50601-41	29,37
16606RLK-40	45,61	35807-40	32,83	50602-36	24,64
16606RLK-41	46,76	35807-41	34,13	50602-37	25,66
16606RLK-42	46,76	35807-42	34,13	50602-38	25,66
16606RLK-43	50,96	35807-43	38,22	50602-39	28,25
16610-38	30,17	35808RLK-40	45,61	50602-40	28,25
16610-39	32,83	35808RLK-41	46,76	50602-41	29,37
16610-40	32,83	35808RLK-42	46,76	50602-42	29,37
16610-41	34,13	35808RLK-43	50,96	50602-43	33,15
16610-42	34,13	35808RLK-44	50,96	50602-44	33,15
16610-43	38,22	38101-50	19,01	50602-45	34,48
16610-44	38,22	38101-51	19,67	50602-46	34,48
16700-35	49,04	38101-60	24,19	50602-48	37,24
16701-44	38,85	38200-46	19,81	50605-36	135,35
16701-45	40,67	38200-50	20,06	50607-38	28,67
16701-47	44,17	38200-52	24,85	50607-39	31,29
16701-48	44,17	38200-54	28,14	50607-41	32,41
16701-49	45,92	38200-63	30,80	50608-39	29,79
16804-44	44,91	41100-53	21,21	50608K-39	32,83
16900-41	35,74	41100-59	24,36	50608K-41	34,13
16900-42	35,74	44201-45	20,79	50608K-42	34,13
185400-38	36,37	44202-44	33,15	50608K-43	38,22
185500-38	40,46	44202-46	34,48	50609-37	27,13
185501-38	36,37	44203-38	25,66	50609-38	27,13
35100-43	41,20	44203-39	28,25	50609-39	29,79
35100-44	43,02	44203-40	28,25	50609-42	31,08
35101-45	24,64	44203-41	29,37	50609-43	35,18
35102-46	27,62	44203-42	29,37	50611-37	126,35



CORONE ACCIAIO STEEL REAR SPROCKETS

Code	€	Code	€	Code	€
50611-38	126,35	71304-44	33,15	92114-59	30,21
50612-36	26,01	71304-45	34,48	92115-50	22,61
50612-39	29,79	71304-46	35,11	92115-51	23,49
50613-39	31,29	71304-48	37,24	92115-58	29,79
50613-43	36,16	71304-50	38,71	92122-52	21,53
50613-44	36,16	71304-51	41,76	92122-60	32,20
50613-46	37,52	71304-52	43,23	92127-32	13,23
50614-41	128,77	71304-53	43,23	92127-42	15,23
50614-43	129,19	71305-37	25,66	92213-48	21,70
50800-39	137,83	71305-38	25,66	92213-50	23,84
50800-41	138,64	71305-39	28,25	92216-48	21,70
50800-42	138,64	71800-42	31,08	92216-54	28,14
50800-43	141,30	71801-37	27,13	92217-49	23,84
50800-45	142,17	71801-38	27,13	92218-34	25,41
50801-38	136,08	71801-41	31,08	92218-38	28,67
50801-39	137,83	71900-38	30,17	92220-60	29,16
50801-43	141,30	74100-30	21,49	92221-42	45,43
50803K-37	30,17	74100-31	21,49	92221-45	46,73
50803K-38	30,73	74101-28	13,44	92221-46	47,32
50803K-39	32,83	74200-42	18,76	92223-41	27,62
50803K-40	32,83	74300-36	24,64	92223-43	27,62
50803K-41	34,13	74300-38	25,66	92324-32	21,49
50803K-42	34,13	80101-44	19,71	92325-35	27,69
50804K-37	28,67	80103-48	20,51	92328-40	28,25
50804K-38	28,67	80104-47	20,51	92401-39	28,25
50804K-40	31,29	80105-48	20,51	92401-42	29,37
50804K-41	32,41	80105-52	23,49	92503-47	40,25
50804K-42	32,41	80200-46	21,70	92505-40	34,13
50804K-43	34,90	83200-49	48,65	92606-42	29,37
50806-43	151,38	83201-49	23,84	92606-43	33,15
50807-43	38,85	86500-42	34,13	92622RLK-40	45,61
50900-40	148,75	86500-43	38,22	92622RLK-41	46,76
50901-39	137,83	86600-40	34,13	92622RLK-42	46,76
50901-41	138,64	86600-42	35,74	92622RLK-43	50,96
50901-42	140,14	86600-43	38,85	92622RLK-44	50,96
50902-43	48,97	86600-44	38,85	92622RLK-45	52,43
53104-58	34,09	86600-45	40,67	92622RLK-46	52,43
56102-46	20,51	86600-46	40,67	92622RLK-47	53,52
56103-46	20,51	86600-48	44,17	92622RLK-48	53,52
56103-52	23,49	86601-42	35,74	92622RLK-49	54,99
56200-51	24,85	86601-43	38,85	92622RLK-50	54,99
56201-51	24,85	86601-45	40,67	92630-40	29,79
56501-43	50,33	86603-40	37,24	92630-41	31,08
59102-46	24,12	86603-42	38,85	92630-44	35,18
59104-44	20,79	86603-43	41,97	92630-45	36,51
59104-47	21,70	86603-44	41,97	92631-45	40,67
59104-53	18,59	86603-45	43,79	92634-41	34,13
59104-56	24,47	86603-46	43,79	92634-42	34,13
59104-60	31,64	86604-42	34,13	92635-41	34,13
59207-48	21,70	86605-37	30,17	92635-42	34,13
62800-42	34,13	86605-39	32,20	92635-47	42,60
65200-52	24,85	86605-42	34,13	92666-39	29,79
65201-51	14,07	86605-44	37,66	92666-40	29,79
65300-46	34,48	86605-46	39,55	92666-42	31,08
65301-46	34,48	86605-47	42,60	92667-41	128,77
65500-44	35,18	86605-50	44,21	92667-43	131,22
71202-42	32,41	86606-41	29,37	92668-40	29,79
71202-45	37,52	86608-43	33,15	92668-41	31,08
71202-46	37,77	86609-42	32,41	92668-42	31,08
71304-38	25,66	92109-56	29,23	92668-43	35,18
71304-40	28,25	92113-50	48,65	92668-44	35,18
71304-41	29,26	92114-52	20,58	92668-45	36,51
71304-42	29,37	92114-53	21,21	92671-36	26,01



CORONE ACCIAIO STEEL REAR SPROCKETS

Code	€	Code	€	Code	€
92671-41	31,08	10212SLK+50	62,65	14206SLK+49	62,65
92671-42	31,08	10212SLK+51	65,84	14206SLK+50	62,65
92671-43	35,18	10212SLK+52	67,38	14206SLK+51	65,84
92671-44	34,62	12323K-48	47,39	16206K-49	49,00
92803-40	34,13	12323K-49	49,00	16206K-50	49,00
92803-48	44,17	12323K-50	49,00	16206SLK+48	61,11
92836-40	29,79	12323K-51	52,40	16206SLK+49	62,65
92836-41	31,08	12323K-52	54,04	16206SLK+50	62,65
92836-43	35,18	12323SLK+47	61,11	16206SLK+51	65,84
92837-40	29,79	12323SLK+48	61,11	16206SLK+52	65,84
95300-41	29,37	12323SLK+49	62,65	38300SLK+48	61,11
98300-30	24,50	12323SLK+50	62,65	38300SLK+49	62,65
98300-34	25,41	12323SLK+51	65,84	38300SLK+50	62,65
98300-36	27,69	12323SLK+52	67,38	71102SLK+46	65,77
98300-38	28,67	12323SLK+53	67,38	71102SLK+49	68,57
98300-40	31,29	14203K-48	47,39	71304K-48	47,39
98300-42	32,41	14203K-49	49,00	71304K-49	49,00
98500-37	28,67	14203K-50	49,00	71304K-50	49,00
98500-38	28,67	14203SLK+47	61,11	71304K-51	52,40
10212K-48	47,39	14203SLK+48	61,11	71304K-52	54,04
10212K-49	49,00	14203SLK+49	62,65	71304SLK+47	61,11
10212K-50	49,00	14203SLK+50	62,65	71304SLK+48	61,11
10212K-51	52,40	14203SLK+51	65,84	71304SLK+49	62,65
10212SLK+46	61,11	14206K-48	47,39	71304SLK+50	62,65
10212SLK+47	61,11	14206K-49	49,00	71304SLK+51	65,84
10212SLK+48	61,11	14206K-50	49,00	71304SLK+52	67,38
10212SLK+49	62,65	14206SLK+48	61,11		

CORONE ALLUMINIO ALUMINIUM REAR SPROCKETS



Code	€	Code	€	Code	€
11101N-36	31,99	11506-36 PS	38,82	13323N-52	53,06
11104+49	45,68	11506-38 PS	43,61	13323PB+48	52,57
11104+55	52,92	11508-43	74,90	13323PB+49	53,52
11104N-49	41,65	11509-40	55,16	13323PB+50	55,58
11104N-50	41,65	11509-41	56,28	13323PB+51	56,63
11104N-51	44,03	11509-42	59,61	13407-36	38,82
11104N-52	46,38	11509-43	60,38	13407-37	42,84
11104N-53	46,38	11509-44	60,38	13407-38	43,61
11104N-55	48,83	11509-45	61,36	13407-39	44,14
11104N-56	50,40	11509-46	61,36	13407-40	44,14
11110-50	49,00	11509-47	64,68	13500-40	44,14
11111+56	60,90	11509-48	65,17	13508+48	55,02
11111-50	46,38	11509-49	65,17	13508N-48	51,49
11113N-37	32,80	11509-50	66,99	13508N-49	51,49
11201-55	56,98	11509-52	66,99	13508N-50	52,05
11207-35	41,37	11522-42	39,20	13508N-51	52,54
11207-36	42,11	11605-42	72,10	13508N-52	53,06
11207-37	43,23	11613-42	64,65	13604-46	61,81
11207-38	43,23	11613-43	66,47	13604-47	65,17
11207-39	43,72	11613-44	66,47	13604-48	65,17
11207-40	46,90	11616-40	63,67	13801-38 PS	63,04
11207-41	48,06	11616-41	66,47	13801-39 PS	63,67
11207-42	48,06	11616-42	72,10	13813-41	66,47
11208-54	56,98	11616-43	74,90	13813-42	72,10
11212+45	52,64	11616-44	74,90	13813-43	74,90
11212+46	52,64	11616-45	77,70	13813-44	74,90
11212+47	54,53	11617-42	64,65	13813-45	77,70
11212+48	55,02	11617-43	66,47	13813-46	77,70
11212+49	55,48	11617-44	66,47	13813-47	81,97
11212+50	56,84	11618-40	51,49	13813-48	81,97
11212+51	57,93	11618-41	54,36	13814-40	53,34
11212+52	59,01	11618-42	57,16	13814-41	55,51
11212+53	62,51	11618-43	59,92	13814-42	58,38
11212+54	63,21	11618-44	59,92	13814-43	59,92
11212N-41	46,59	11618-45	61,81	13814-44	59,92
11212N-42	48,58	11618-46	61,81	13814-45	61,81
11212N-43	50,51	11618-47	65,17	13814-46	62,69
11212N-44	50,51	11618-48	65,17	13814-47	65,17
11212N-45	51,21	11618-50	70,42	13814-48	65,17
11212N-46	51,21	11618-54	78,58	13814-49	65,17
11212N-47	51,49	11618-60	97,41	13814-50	68,04
11212N-48	51,49	13108-46	44,84	13814-51	69,09
11212N-49	51,49	13116+47	45,15	13815-43	66,47
11212N-50	52,05	13208-51	51,38	13815-44	66,47
11212N-51	52,54	13227-46 PS	46,80	13815-45	69,27
11212N-52	53,06	13227-47 PS	48,44	13815-46	69,27
11212N-53	57,58	13301-52	65,07	13815-47	73,61
11212PK+50	55,58	13311-42	54,11	13817-41	54,36
11212PR+48	52,57	13312-42	61,22	13817-42	57,16
11212PR+49	53,52	13323+46	52,64	13817-43	59,92
11212PR+50	55,58	13323+47	54,53	13817-44	59,92
11228+62	72,63	13323+48	55,02	15104+47	49,95
11304-43 PS	51,38	13323+49	55,48	15104+48	49,95
11310-40 PS	44,14	13323+50	56,84	15104+49	50,54
11315-40	44,14	13323+51	57,93	15104+50	50,54
11413-42 PS	49,00	13323+52	59,01	15104+51	52,92
11413-43 PS	51,38	13323+54	63,21	15104+52	56,91
11413-44 PS	51,38	13323-45	51,21	15104+53	56,91
11413-45 PS	52,99	13323N-47	51,49	15104N-47	46,38
11413-46 PS	52,99	13323N-48	51,49	15104N-48	46,38
11504-44 PS	66,47	13323N-49	51,49	15104N-49	46,38
11504-45 PS	69,27	13323N-50	52,05	15104N-50	46,38
11504-47 PS	73,61	13323N-51	52,54	15104N-51	48,83



CORONE ALLUMINIO ALUMINIUM REAR SPROCKETS

Code	€	Code	€	Code	€
15104N-52	52,82	15605-47	65,17	17206N-46	51,21
15104N-53	52,82	15605-48	65,17	17206N-47	51,49
15203+47	54,53	15605-49	65,17	17206N-48	51,49
15203+48	55,02	15605-50	73,29	17206N-49	51,49
15203+49	55,48	15902-42	72,10	17206N-50	52,05
15203+50	56,84	15902-45	77,70	17206N-51	52,54
15203+51	57,93	15902-47	81,97	17206N-52	53,06
15203+52	59,01	165601-43	89,36	17206N-53	57,58
15203+53	62,51	165601-44	89,36	17206PK+50	55,58
15203N-43	50,51	165601-45	92,12	17404-40	51,49
15203N-44	50,51	165601-46	92,12	17404-41	54,36
15203N-45	51,21	165800-42	64,65	17404-42	57,16
15203N-46	51,21	165800-43	66,47	17404-43	59,92
15203N-47	51,49	165800-44	66,47	17404-44	59,92
15203N-48	51,49	165800-45	69,27	17404-45	61,81
15203N-49	51,49	165800-46	69,27	17404-46	61,81
15203N-50	52,05	165800-47	73,61	17404-47	65,17
15203N-51	52,54	165801-39	51,49	17404-48	65,17
15203N-52	53,06	165801-40	51,49	17500-43	59,92
15203N-53	57,58	165801-41	54,36	17500-44	59,92
15203PK+49	53,52	165801-42	57,16	17603-40	63,67
15206+48	55,02	165801-43	59,92	17603-42	72,10
15206+49	55,48	165801-44	59,92	17603-43	74,90
15206+50	56,84	165801-45	61,81	17604-42	72,10
15206+51	57,93	165801-46	61,81	17604-43	74,90
15206+52	59,01	165801-47	65,17	17604-44	74,90
15206N-42	48,58	165801-48	65,17	17606-38	50,89
15206N-43	50,51	165803-39	51,49	17606-39	51,49
15206N-44	50,51	165803-40	51,49	17606-40	51,49
15206N-45	51,21	165803-41	54,36	17606-41	54,36
15206N-46	51,21	165803-42	57,16	17606-42	57,16
15206N-47	51,49	165803-43	59,92	17606-43	59,92
15206N-48	51,49	165803-44	59,92	17606-44	59,92
15206N-49	51,49	165803-45	61,81	17606-45	61,81
15206N-50	52,05	17100N-44	36,82	17606-46	61,81
15206N-51	52,54	17104+49	45,68	17606-47	65,17
15206N-52	53,06	17104+50	45,68	17606-48	65,17
15206N-53	57,58	17104+51	48,13	17606-49	65,17
15305-48	57,23	17104+53	50,54	17610-39	57,16
15310-40	44,14	17104+54	52,92	17610-40	57,16
15404-44	66,47	17104N-49	41,65	17610-41	59,92
15404-45	69,27	17104N-50	41,65	17610-42	64,65
15404-47	73,61	17104N-51	44,03	17610-43	66,47
15405-39	51,49	17104N-52	46,38	17610-44	66,47
15405-44	59,92	17104N-54	48,83	17610-45	69,27
15405-45	61,81	17105+50	50,54	17900-41	66,47
15405-46	61,81	17105+51	52,92	36305-42	50,23
15405-47	65,17	17105+54	58,52	36306-42	57,16
15405-48	65,17	17105-50	46,38	36306-43	59,92
15604-40	57,16	17105-51	48,83	36306-44	59,92
15604-42	64,65	17107+47	45,15	36400+48	55,02
15604-43	66,47	17107N-46	40,78	36400N-46	48,72
15604-44	66,47	17107N-47	41,65	36400N-51	52,54
15604-45	69,27	17206+46	52,64	36800-41	59,92
15604-46	69,27	17206+48	55,02	36800-42	64,65
15604-47	73,61	17206+49	55,48	36800-43	66,47
15605-40	51,49	17206+50	56,84	36801-38	50,89
15605-41	54,36	17206+51	57,93	36801-40	51,49
15605-42	57,16	17206+52	59,01	36801-41	54,36
15605-43	59,92	17206+53	62,51	36801-42	57,16
15605-44	59,92	17206N-42	48,58	36801-43	59,92
15605-45	61,81	17206N-44	50,51	36801-44	59,92
15605-46	61,81	17206N-45	51,21	36801-45	61,81

CORONE ALLUMINIO ALUMINIUM REAR SPROCKETS



Code	€	Code	€	Code	€
36802-41	59,92	51804-43	57,82	72304PR+50	55,58
36802-42	64,65	54101-44	46,90	72304PR+51	56,63
36802-43	66,47	54102-54	56,98	72304PR+52	57,68
36807-40	57,16	60101-53	52,82	72304PR+53	60,76
36807-41	59,92	60104-56	56,81	72306+46	52,64
36807-42	64,65	60201-42	50,23	72306+48	55,02
36807-43	66,47	60300-39	45,12	72801-38	56,53
36808-40	51,49	63300-52	60,06	72801-40	57,16
36808-41	54,36	63300-53	66,43	72801-41	59,92
36808-42	57,16	72101+46	44,35	72801-42	64,65
36808-43	59,92	72101+47	45,15	78303-40	45,12
39100-60	60,06	72101+48	45,15	78303-42	50,23
39300+48	55,02	72101+50	45,68	87601-42	72,10
39300+49	55,48	72101N-46	40,78	87601-45	77,70
39300+50	56,84	72101N-48	41,65	87603-41	66,47
48200-58	59,89	72101N-50	41,65	87603-42	72,10
48200-60	63,07	72102+46	48,34	87603-43	74,90
48200-62	71,09	72102+47	49,95	87603-44	74,90
51600-33	52,29	72102+48	49,95	87603-45	77,70
51600-38	63,04	72102+49	50,54	87605-47	73,61
51602-38	50,89	72102+50	50,54	87606-45	61,81
51602-40	51,49	72102+51	52,92	87606-46	61,81
51602-41	54,36	72102N-46	44,84	87606-47	65,17
51602-42	57,16	72102N-49	46,38	87606-48	65,17
51602-43	59,92	72102N-51	48,83	87606-49	65,17
51602-44	59,92	72103N-44	44,00	93106-56	59,36
51602-45	61,81	72104-44	36,82	93111-56	56,81
51602-46	61,81	72105-40	46,90	93117-50	49,00
51607-37	49,98	72105-42	48,06	93117-56	59,36
51607-38	50,89	72106-40	33,64	93118-60	61,60
51607-39	51,49	72106-42	34,41	93212-57	56,81
51607-40	51,49	72301-52	60,06	93303-40	47,57
51607-41	54,36	72301-57	73,64	93303-41	47,71
51607-42	57,16	72303-48	52,82	93303-42	53,06
51607-43	59,92	72303-50	60,06	93303-44	55,65
51608-37	54,60	72303-52	60,06	93314+51	57,93
51608-38	56,53	72304+45	52,64	93314-49	49,28
51608-39	57,16	72304+46	52,64	93314-50	51,03
51608-41	59,92	72304+47	54,53	93314-51	51,03
51608-42	64,65	72304+48	55,02	93314-52	51,03
51608-43	66,47	72304+49	55,48	93319-38	45,12
51609-37	54,60	72304+50	56,84	93320-39	44,42
51609-38	56,53	72304+51	57,93	93320-41	47,71
51609-43	66,47	72304+52	59,01	93320-42	50,23
51612-37	54,60	72304+53	62,51	93320-43	52,89
51612-39	57,16	72304N-38	44,70	93321-48	57,23
51612-41	59,92	72304N-40	44,87	93323-42	50,23
51612-42	64,65	72304N-41	46,59	93329-33	54,11
51613-39	51,49	72304N-42	48,58	93329-34	55,27
51613-40	51,49	72304N-43	50,51	93329-35	55,09
51613-41	54,36	72304N-44	50,51	93329-36	57,37
51613-43	59,92	72304N-45	51,21	93329-37	57,54
51803-38	56,53	72304N-46	51,21	93329-38	61,32
51803-39	57,16	72304N-47	51,49	93329-39	62,02
51803-40	57,16	72304N-48	51,49	93329-40	63,91
51803-41	59,92	72304N-49	51,49	93329-41	66,08
51803-42	64,65	72304N-50	52,05	93329-42	66,08
51804-37	49,98	72304N-51	52,54	93331-32	49,60
51804-38	50,89	72304N-52	53,06	93331-33	49,60
51804-39	51,49	72304PK+50	55,58	93331-34	50,65
51804-40	51,49	72304PO+48	52,57	93331-35	52,01
51804-41	54,36	72304PO+50	55,58	93331-36	53,13
51804-42	57,16	72304PO+51	56,63	93331-37	53,24

CORONE ALLUMINIO ALUMINIUM REAR SPROCKETS

Code	€	Code	€	Code	€
93331-38	54,04	93604-44	59,92	93622-43	59,92
93331-39	54,67	93605-41	54,36	93622-44	59,92
93331-40	58,66	93605-42	57,16	93622-45	61,81
93331-41	60,06	93622-37	49,98	93622-46	61,81
93331-42	60,06	93622-38	50,89	93622-47	65,17
93604-37	49,98	93622-39	51,49	93800-40	63,67
93604-41	54,36	93622-40	51,49	93836-40	57,16
93604-42	57,16	93622-41	54,36	93836-41	59,92
93604-43	59,92	93622-42	57,16	93836-43	66,47

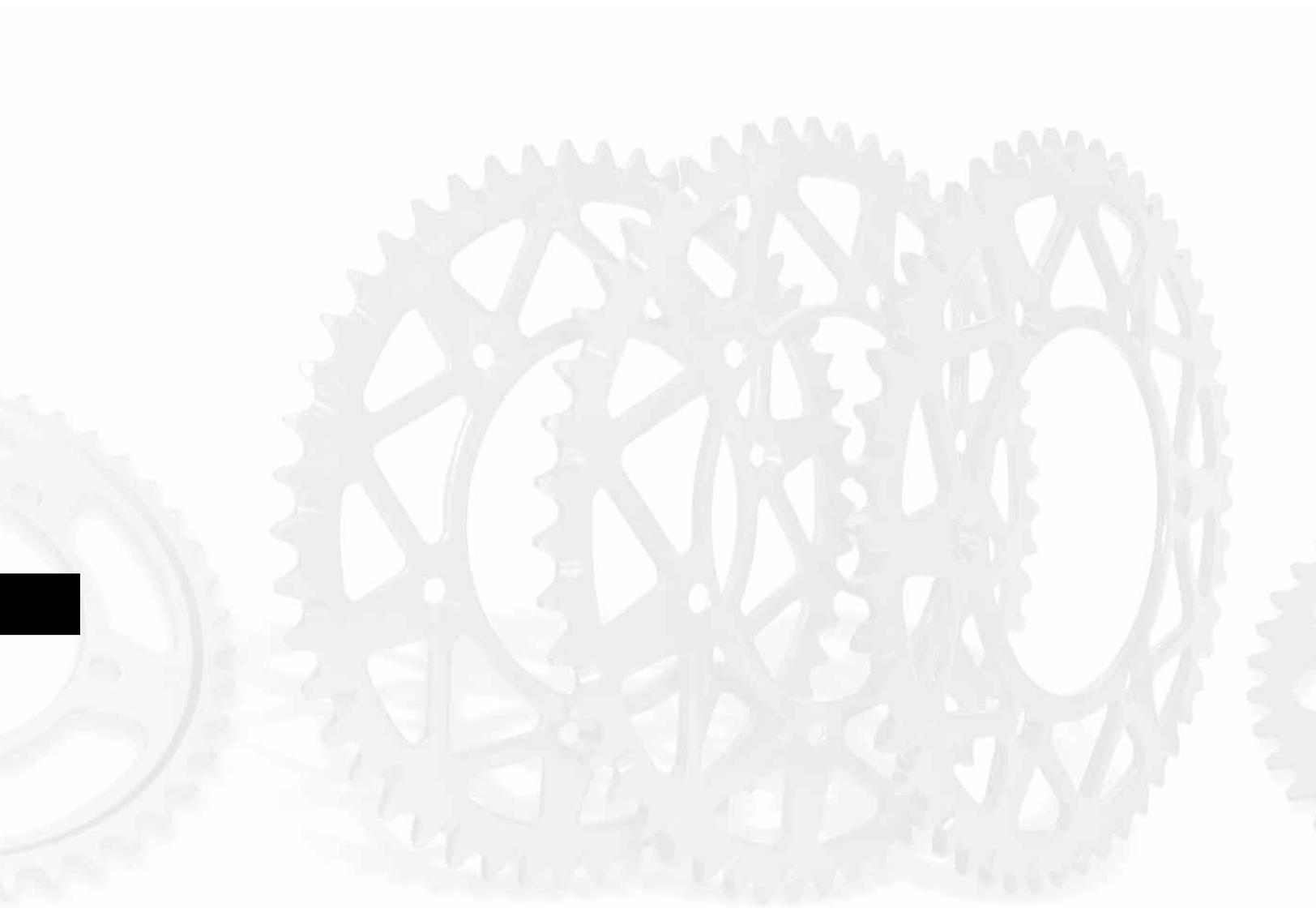

**PORTA CORONE ALLUMINIO PER DUCATI
DUCATI ALUMINIUM SPROCKETS CARRIER**



Code	€
PCD1	180,00 *
PCD2	180,00 *
PCD3	180,00 *
PCD4	180,00 *
PCD5	180,00 *

(*) Attenzione prezzo netto per negozio

**CORONE RACING #520 IN ALLUMINIO PER RUOTA MARCHESINI / OZ
RACING #520 ALU REAR SPROCKETS FOR MARCHESINI / OZ WHEELS**

Code	€	Code	€	Code	€
93622-37	49,98	93622-41	54,36	93622-45	61,81
93622-38	50,89	93622-42	57,16	93622-46	61,81
93622-39	51,49	93622-43	59,92	93622-47 PS	65,17
93622-40	51,49	93622-44	59,92		

KIT TRASMISSIONE

TRASMISSIONE





KIT AFAM / AFAM KIT

Codice Kit Code	Applicazione Application	Anno Year	Pignone F. Sprocket	Corona R. Sprocket	Passo Pitch	Mg. Nm	€
APRILIA							
3501161	50 50 Classic	'92→'01	94108-13	35102-46	415	130	58,28
3501200	50 50 Tuono	'20→'05	94119-11	35104-47	420	124	44,10
3501601	50 AE 50 Pegaso	'92→'96	94108-13	35101-45	415	126	54,74
3501601	50 AE 50 RXR	'92→'95	94108-13	35101-45	415	126	54,74
3501247	50 AF1 50 Europa	'90→'92	94100-11	35100-43	415	126	70,56
3501247	50 AF1 50 Futura	'90→'92	94100-11	35100-43	415	126	70,56
3501636	50 MX 50	'03→'05	94119-11	35103-51	420	126	42,81
3501241	50 RS 50	'95→'98	94107-12	35100-44	415	122	71,93
3501240	50 RS 50	'93→'94	94108-13	35100-43	415	124	70,95
3501242	50 RS 50	'99→'02	94119-12	35104-47	420	124	44,35
3501243	50 RS 50	'03→'05	94119-11	35104-47	420	124	44,10
3501245	50 RS 50	'06→'11	49102-11	92114-53	420	132	42,67
3501248	50 RS4 50	'11→'16	49102-11	92114-53	420	132	42,67
3501249	50 RS4 50	'18→'20	49102-11	92114-59	420	134	51,92
3501603	50 RX 50	'95→'98	94109-12	35103-51	420	126	43,75
3501604	50 RX 50	'99→'01	94119-12	35103-51	420	126	17,02
3501606	50 RX 50	'06→'16	49102-11	47103-53	420	130	41,44
3501605	50 RX 50 Racing	'02→'06	94119-11	35103-51	420	126	42,81
3501637	50 SX 50 Super Motard	'06→'11	49102-11	47103-53	420	130	41,44
3501638	50 SX 50 Super Motard	'12→'16	49102-11	92114-53	420	130	42,42
3513162	125 125 Classic	'95→'01	61201-15	35206-40	520	112	74,69
3513602	125 125 Pegaso	'89→'91	61201-14	44203-40	520	104	63,49
3513603	125 125 Pegaso	'92→'96	61201-15	44203-42	520	104	65,07
3513609	125 125 Tuareg Rally	'90→'94	61201-15	35204-49	520	108	75,29
3513601	125 125 Tuareg Wind	'89→'91	61201-14	44203-41	520	104	64,61
3513200	125 125 Tuono	'03→'07	61201-17	44203-40	520	106	65,24
3513201	125 125 TUONO	'17→'20	37200-13	92220-60	428	136	93,77
3513302	125 AF1 125 Europa	'90→'94	61201-16	35200-38	520	106	71,19
3513303	125 AF1 125 SPORT PRO F40	'92→'93	61201-16	35200-38	520	108	71,65
3513605	125 ETX 125	'99→'02	61201-16	35204-45	520	110	72,00
3513304	125 RS 125	'96→'98	61201-16	44203-39	520	106	64,89
3513305	125 RS 125	'99→'05	61201-17	44203-40	520	106	65,24
3513306	125 RS 125	'06→'12	61201-17	35801-40	520	106	75,89
3513241	125 RS4 125	'14→'17	37200-13	92220-60	428	136	93,77
3513241	125 RS4 125 New Driven Shaft	'11→'13	37200-13	92220-60	428	136	93,77
3513604	125 RX 125 E	'93→'99	61201-17	35204-49	520	114	77,46
3513607	125 RX 125 R	'92→'95	61201-14	35204-49	520	108	74,84
3513242	125 RS4 Old Driven Shaft	'11→'13	37201-13	92220-60	428	136	94,37
3513637	125 SX	'08→'11	61201-17	35204-45	520	112	72,77
3513638	125 SX	'18→'20	49200-14	47203-62	428	140	100,86
3526300	250 RS 250	'95→'03	27500-14	35306-42	520	110	103,11
3535503	350 ETX 350 Tuareg	'85→'87	61301-15	35303-46	520	104	113,05
3535502	350 ETX 350 Tuareg Wind	'88→'89	61302-16	35304-45	520	108	118,62
3535500	350 ETX 4.35	'88	61302-15	35303-43	520	106	114,88
3535501	350 ETX 6.35	'88	61302-15	35303-46	520	108	117,39
3570500	600 600 Pegaso	'90→'92	61302-17	35304-43	520	108	122,92
3570500	600 600 Tuareg Wind	'87→'91	61302-17	35304-43	520	108	122,92
3570501	600 ETX 600 Tuareg	'85→'87	61302-15	35303-46	520	104	119,70
3573636	650 6,5 Moto 6.5	'95→'01	61302-16	35304-49	520	108	127,61
3573502	650 650 ie Pegaso	'01→'04	61301-16	35304-46	520	110	122,30
3573638	650 650 ie Pegaso Factory	'06→'10	21510-15	35304-44	520	110	119,99
3573637	650 650 ie Pegaso Strada	'05→'10	21510-15	35801-44	520	110	119,99
3573503	650 650 ie Pegaso Trail	'06→'08	21510-15	35304-44	520	110	119,99
3573500	650 650 Pegaso	'93→'95	61500-16	35304-47	520	110	128,14
3573501	650 650 Pegaso	'96	61301-16	35304-47	520	110	125,03
3573504	650 650 Pegaso III	'97→'01	61301-16	35304-47	520	110	125,03



KIT AFAM / AFAM KIT

Codice Kit Code	Applicazione Application	Anno Year	Pignone F. Sprocket	Corona R. Sprocket	Passo Pitch	Mg. Nm	€
3577636	750 750 Dorsoduro	'08→'12	37600-16	35802-46	525	112	172,83
3577637	750 750 Dorsoduro ABS	'13	37600-16	35802-46	525	112	172,83
3577636	750 750 Dorsoduro ABS	'14→'16	37600-16	35802-46	525	112	172,83
3577636	750 750 Dorsoduro Factory ABS	'10→'13	37600-16	35802-46	525	112	172,83
3577131	750 750 GT Shiver	'09→'10	37600-16	35802-44	525	108	167,72
3577132	750 750 GT Shiver ABS	'10→'13	37600-16	35802-44	525	108	167,72
3577131	750 750 RA Shiver	'07→'10	37600-16	35802-44	525	108	167,72
3577131	750 750 RAE Shiver	'10→'15	37600-16	35802-44	525	108	167,72
3577132	750 750 RAE Shiver ABS	'13→'16	37600-16	35802-44	525	108	167,72
3583131	850 NA 850 Mana	'07→'13	37601-18	35802-40	525	110	174,51
3583132	850 NA 850 Mana ABS	'13	37601-18	35802-40	525	110	174,51
3583131	850 NA 850 Mana GT ABS	'09→'13	37601-18	35802-40	525	110	174,51
3586636	900 900 Dorsoduro ABS	'17→'17	37600-15	35802-44	525	112	169,65
3586131	900 900 Shiver ABS	'17→'17	37600-16	35802-44	525	108	167,72
3589551	1000 ETV 1000 Caponord	'01→'03	61600-17	35804-45	525	112	202,79
3589551	1000 ETV 1000 Caponord ABS	'04→'08	61600-17	35804-45	525	112	202,79
3589552	1000 ETV 1000 Caponord Rally	'01→'09	61600-16	35804-45	525	112	201,36
3589200	1000 RST 1000 Futura	'01→'04	61600-16	35803-43	525	108	195,17
3589242	1000 RSV 1000	'04→'08	61600-16	35802-40	525	106	187,33
3589241	1000 RSV 1000	'98→'03	61600-17	35800-42	525	108	192,51
3589242	1000 RSV 1000 R Factory	'04→'08	61600-16	35802-40	525	106	187,33
3589242	1000 RSV 1000 R Racing Factory	'04→'08	61600-16	35802-40	525	106	187,33
3589133	1000 RSV 1000 R Tuono	'06→'10	61600-16	35802-40	525	106	187,33
3589132	1000 RSV 1000 R Tuono	'02→'05	61600-17	35800-42	525	108	192,51
3589134	1000 RSV 1000 R Tuono Factory	'06→'10	61600-16	35802-40	525	108	189,78
3589241	1000 RSV 1000 SP	'99→'00	61600-17	35800-42	525	108	192,51
3589245	1000 RSV4 1000 APRC R	'12→'13	61801-16	35807-42	525	110	193,45
3589245	1000 RSV4 1000 APRC R ABS	'13→'14	61801-16	35807-42	525	110	193,45
3589245	1000 RSV4 1000 APRC SE Factory	'11→'12	61801-16	35807-42	525	110	193,45
3589245	1000 RSV4 1000 APRC SE Factory ABS	'13→'14	61801-16	35807-42	525	110	193,45
3589243	1000 RSV4 1000 Factory	'09→'10	61801-16	35807-40	525	108	189,78
3589244	1000 RSV4 1000 R	'10→'11	61801-16	35807-40	525	108	189,78
3589246	1000 RSV4 1000 RF Racing Factory	'15→'17	61801-16	35807-41	525	110	193,45
3589246	1000 RSV4 1000 RR	'15→'17	61801-16	35807-41	525	110	193,45
3592241	1000 RSV4 1100 FACTORY	'19→'20	61801-16	35807-41	525	110	193,45
3589135	1000 RSV4 1000 V4 APRC R Tuono	'11→'13	61801-16	35807-42	525	110	193,45
3589245	1000 RSV4 1000 V4 APRC R Tuono ABS	'13	61801-16	35807-42	525	110	193,45
3589135	1000 RSV4 1000 V4 APRC R Tuono ABS	'14	61801-16	35807-42	525	110	193,45
3589131	1000 SL 1000 Falco	'99→'04	61600-16	35800-41	525	106	188,62
3592131	1100 V4 1100 RR Tuono	'15→'17	61801-15	35807-42	525	110	191,70
3592131	1100 V4 1100 Tuono Factory	'15→'16	61801-15	35807-42	525	110	191,70
3595551	1200 1200 Caponord	'13→'16	37600-17	35802-42	525	112	199,85
3595551	1200 1200 Caponord Rally	'15→'16	37600-17	35802-42	525	112	199,85
3595636	1200 1200 Dorsoduro ABS	'11→'14	37600-16	35802-40	525	108	191,91

APRILIA KIT TRASFORMAZIONE PASSO # 520

3501600	50 50 Wind	'88→'90	94100-12	54101-44	415	122	76,13
3613306	125 RS 125	'06→'12	61201-17	36801-40	520	106	96,08
3626300	250 RS 250	'95→'03	27500-14	36306-42	520	110	134,40
3651636	450 450 SXV 2006-2011	'06→'11	37400-15	36400N-46	520	112	138,33
3668636	550 550 SXV 2006-2011	'06→'11	37400-16	36400N-46	520	112	167,55
3689403	1000 RSV 1000	'04→'08	61601-16	36801-40	520	106	201,22
3689403	1000 RSV 1000 R Factory	'04→'08	61601-16	36801-40	520	106	201,22



KIT AFAM / AFAM KIT

Codice Kit Code	Applicazione Application	Anno Year	Pignone F. Sprocket	Corona R. Sprocket	Passo Pitch	Mg. Nm	€
3689403	1000 RSV 1000 R Racing Factory	'04→'08	61601-16	36801-40	520	106	201,22
3589405	1000 RSV4 1000 FACTORY #520 steel	'09→'10	61802-16	35808RLK-40	520	108	197,68
3589406	1000 RSV4 1000 R #520steel	'10→'11	61802-16	35808RLK-40	520	108	197,68
3589407	1000 RSV4 1000 APRC R #520 steel	'10→'14	61802-16	35808RLK-42	520	110	201,19
3589408	1000 RSV4 1000 RR/RF #520 steel	'15→'20	61802-16	35808RLK-41	520	110	201,19
3689407	1000 RSV4 1000 APRC R	'12→'13	61802-16	36808-42	520	110	211,58
3689407	1000 RSV4 1000 APRC R ABS	'13→'14	61802-16	36808-42	520	110	211,58
3689407	1000 RSV4 1000 APRC SE Factory	'11→'12	61802-16	36808-42	520	110	211,58
3689407	1000 RSV4 1000 APRC SE Factory ABS	'13→'14	61802-16	36808-42	520	110	211,58
3689405	1000 RSV4 1000 Factory	'09→'10	61802-16	36808-40	520	108	203,53
3689406	1000 RSV4 1000 R	'10→'11	61802-16	36808-40	520	108	203,53
3689408	1000 RSV4 1000 RF Racing Factory	'15→'17	61802-16	36808-41	520	110	208,78
3689408	1000 RSV4 1000 RR	'15→'17	61802-16	36808-41	520	110	208,78
3692401	1100 RSV4 1100 Factory #520 aluminum	'19→'20	61802-16	36808-41	520	110	208,78
3592401	1100 RSV4 1100 Factory #520 steel	'19→'20	61802-16	35808RLK-41	520	110	201,19

BENELLI

18830200	300 BN 302	'15→'20	21606-14	92671-44	525	108	128,35
18859133	500 LEONCINO	'19→'20	21606-14	92671-44	525	112	131,20
18859551	500 LEOCINO TRIAL	'19→'20	21606-14	92671-44	525	112	131,20
18859552	502 TRK 502 X	'18→'20	21606-14	92671-44	525	116	134,06
18877131	752 752 S	'19→'20	21606-14	92671-43	525	116	134,62
9286242	899 TNT 899	'13→'16	94900-16	92671-41	525	110	151,31
9286132	899 TNT 899 Cafe Racer	'08→'12	94900-16	92671-41	525	110	151,31
9286135	899 TNT 899 Century Racer	'11→'12	94900-16	92671-41	525	110	151,31
9286133	899 TNT 899 S	'07→'11	94900-16	92671-41	525	110	151,31
9286242	899 TNT 899 Tornado	'07→'16	94900-16	92671-41	525	110	151,31
9286200	899 TRE-K 899	'07→'16	94900-16	92671-41	525	110	151,31
9286241	900 TRE 900 Tornado	'02→'06	94900-16	92671-41	525	114	155,09
9292132	1130 TNT 1130 Cafe Racer	'05→'12	94900-16	92671-36	525	110	176,30
9292134	1130 TNT 1130 Century Racer	'11	94900-16	92671-36	525	110	176,30
9292131	1130 TNT 1130 R Tornado Naked Tre	'13→'16	94900-16	92671-36	525	110	176,30
9292133	1130 TNT 1130 R Tornado R 160	'09→'12	94900-16	92671-36	525	110	176,30
9292200	1130 TNT 1130 Sport	'04→'09	94900-16	92671-36	525	110	176,30
9292131	1130 TNT 1130 Titanium	'05→'06	94900-16	92671-36	525	110	176,30
9292131	1130 TNT 1130 Tornado	'06→'14	94900-16	92671-36	525	110	176,30
9292131	1130 TRE 1130 Tornado	'06→'10	94900-16	92671-36	525	110	176,30
9292131	1130 TRE 1130 TR Tornado	'09→'10	94900-16	92671-36	525	110	176,30

BETA

3801639	50 RR 50 Motard	'04→'11	94119-11	38101-50	420	126	40,43
3801642	50 RR 50 Motard	'12→'18	94119-11	38101-50	420	132	41,17
3801641	50 RR 50 Motard	'04→'11	94118-12	38200-50	428	126	41,51
3801643	50 RR 50 Motard	'12→'18	94118-12	38200-50	428	132	42,28
3801645	50 RR 50 Motard	'18→'20	94119-11	38101-60	420	136	46,88
3801642	50 RR 50 Motard Normal	'15	94119-11	38101-50	420	132	41,17
3801643	50 RR 50 Motard Normal	'15	94118-12	38200-50	428	132	42,28
3801642	50 RR 50 Motard Skull	'11	94119-11	38101-50	420	132	41,17
3801640	50 RR 50 Motard Spoke Wheel	'09→'11	94119-11	38101-50	420	126	40,43
3801644	50 RR 50 Motard Spoke Wheel	'12	94119-11	38101-50	420	132	41,17
3801642	50 RR 50 Motard Sport	'14→'18	94119-11	38101-50	420	132	41,17
3801643	50 RR 50 Motard Sport	'14→'18	94118-12	38200-50	428	132	42,28
3801639	50 RR 50 Motard Standard	'09→'11	94119-11	38101-50	420	126	40,43
3801642	50 RR 50 Motard Standard	'12→'14	94119-11	38101-50	420	132	41,17
3801641	50 RR 50 Motard Standard	'09→'11	94118-12	38200-50	428	126	41,51



KIT AFAM / AFAM KIT

Codice Kit Code	Applicazione Application	Anno Year	Pignone F. Sprocket	Corona R. Sprocket	Passo Pitch	Mg. Nm	€
3801643	50 RR 50 Motard Standard	'12→'14	94118-12	38200-50	428	132	42,28
3801640	50 RR 50 Motard Track	'08→'11	94119-11	38101-50	420	126	40,43
3801644	50 RR 50 Motard Track	'12→'13	94119-11	38101-50	420	132	41,17
3801644	50 RR 50 Motard Track Spoke Wheels	'14→'16	94119-11	38101-50	420	132	41,17
3801755	50 RR 50 Standard	'05→'08	94119-11	38101-51	420	126	41,09
3801757	50 RR 50 Standard	'05→'08	94118-12	38200-50	428	126	41,51
3801637	50 RR 50 Supermoto	'02→'05	94119-13	92115-50	420	126	44,84
3801638	50 RR 50 Supermoto	'01	94202-13	92113-50	428	128	72,14
3813636	125 RR 125 Motard	'08→'09	21200-14	38200-46	428	128	41,55
3813637	125 RR 125 Motard	'10→'13	21207-14	38200-50	428	132	42,35
3813638	125 RR 125 Motard	'11→'16	21208-14	38200-63	428	142	54,22
3835161	350 350 Jonathan	'01→'02	22303-15	35304-42	520	120	120,55
3835162	350 350 Jonathan	'03→'06	22303-15	35304-44	520	122	125,51
BMW							
16431131	330 G 310 R	'16→'20	166300-16	35304-40	520	112	122,12
9273551	650 F 650 Funduro	'97→'03	61301-16	35304-47	520	110	125,03
9273552	650 F 650 GS	'99→'07	61301-16	35304-47	520	112	126,29
9273554	650 F 650 GS	'06→'12	166600-17	92634-41	525	116	143,79
16473551	650 F 650 GS	'06→'12	166600-17	92635-41	525	116	143,79
9273554	650 F 650 GS 30 Years GS	'11	166600-17	92634-41	525	116	143,79
9273552	650 F 650 GS Dakar	'99→'07	61301-16	35304-47	520	112	126,29
9273551	650 F 650 ST Strada	'97→'00	61301-16	35304-47	520	110	125,03
9273551	650 F 650 Standard	'93→'96	61301-16	35304-47	520	110	125,03
16473552	650 G 650 GS	'08→'15	61301-16	35304-47	520	112	126,29
16473553	650 G 650 GS Sertao	'12→'14	61301-16	35304-47	520	112	126,29
9273501	650 G 650 Xchallenge	'07→'09	61301-15	92503-47	520	112	125,34
9273553	650 G 650 Xcountry	'06→'09	61301-16	92503-47	520	112	126,29
16475551	700 F 700 GS	'11→'18	166600-17	92635-42	525	116	143,79
16477551	750 F 750 GS	'17→'20	166601-17	164600-44	525	122	153,46
16473551	800 F 650 GS	'06→'12	166600-17	92635-41	525	116	143,79
9273554	800 F 650 GS	'06→'12	166600-17	92634-41	525	116	143,79
9273554	800 F 650 GS 30 Years GS	'11	166600-17	92634-41	525	116	143,79
16473551	800 F 650 GS 30 Years GS	'11	166600-17	92635-41	525	116	143,79
9280551	800 F 800 GS	'06→'10	166600-16	92634-42	525	116	142,35
16480551	800 F 800 GS	'06→'18	166600-16	92635-42	525	116	142,35
16480551	800 F 800 GS 30 Years GS	'11	166600-16	92635-42	525	116	142,35
16480551	800 F 800 GS Adventure	'12→'18	166600-16	92635-42	525	116	142,35
16480551	800 F 800 GS Triple Black	'12	166600-16	92635-42	525	116	142,35
16480551	800 F 800 GS Trophy	'12	166600-16	92635-42	525	116	142,35
9280131	800 F 800 R	'05→'14	61602-20	92635-47	525	120	160,65
16480131	800 F 800 R	'15→'18	61602-19	92635-47	525	120	158,34
9280131	800 F 800 R Chris Pfeiffer Edition	'09→'11	61602-20	92635-47	525	120	160,65
16483551	850 F 850 GS	'17→'20	166601-17	164600-44	525	122	181,54
16486131	900 F 900 R	'20	166601-17	164600-44	525	122	181,54
16486551	900 F 900 XR	'20	166601-17	164600-44	525	122	181,54
16489131	1000 S 1000 R	'13→'18	166800-17	164800-45	525	120	208,57
16489132	1000 S 1000 R Optional Forged Wheels	'17→'18	166800-17	164802-45	525	120	208,57
16489241	1000 S 1000 RR	'09→'11	166800-17	164800-44	525	118	204,82
16489242	1000 S 1000 RR	'12→'14	166800-17	164800-45	525	118	206,15
16489244	1000 S 1000 RR	'14→'18	166800-17	164800-45	525	120	208,57
16489246	1000 S 1000 RR	'19→'20	166800-17	164600-45	525	120	207,87
16489243	1000 S 1000 RR HP4	'13→'14	166800-17	164802-45	525	118	206,15
16489243	1000 S 1000 RR HP4 Carbon	'13→'14	166800-17	164802-45	525	118	206,15



KIT AFAM / AFAM KIT

Codice Kit Code	Applicazione Application	Anno Year	Pignone F. Sprocket	Corona R. Sprocket	Passo Pitch	Mg. Nm	€
16489245	1000 S 1000 RR Optional Forged Wheels	'14→'18	166800-17	164802-45	525	120	208,57
16489551	1000 S 1000 XR	'15→'18	166800-17	164800-45	525	128	218,33
16489552	1000 S 1000 XR	'20	166800-17	164600-45	525	128	217,63

BMW KIT TRASFORMAZIONE PASSO # 520

16589404	1000 S 1000 R	'13→'20	166801-17	165801-45	520	120	225,93
16489404	1000 S 1000 R #520 RLK (acciaio)	'13→'20	166801-17	164801RLK-45520		120	216,55
16589407	1000 S 1000 R Optional Forged Wheels	'17→'20	166801-17	165803-45	520	120	225,93
16489407	1000 S 1000 R Forged Wh #520 RLK (acc.)	'17→'20	166801-17	164803RLK-45520		120	216,55
16489401	1000 S 1000 RR #520 RLK (acciaio)	'09→'11	166801-17	164801RLK-44520		118	212,74
16589401	1000 S 1000 RR	'09→'11	166801-17	165801-44	520	118	221,70
16589402	1000 S 1000 RR	'12→'15	166801-17	165801-45	520	118	223,59
16489402	1000 S 1000 RR #520 RLK (acciaio)	'12→'15	166801-17	164801RLK-45520		118	214,21
16589405	1000 S 1000 RR	'14→'18	166801-17	165801-45	520	120	225,93
16489405	1000 S 1000 RR RACE #520 RLK (acc.)	'14→'18	166801-17	164801RLK-45520		120	216,55
16589403	1000 S 1000 RR HP4	'13→'14	166801-17	165803-45	520	118	252,79
16489403	1000 S 1000 RR HP4 #520 RLK (acc.)	'13→'14	166801-17	164803RLK-45520		118	75,85
16589403	1000 S 1000 RR HP4 Carbon	'13→'14	166801-17	165803-45	520	118	252,79
16589406	1000 S 1000 RR Optional Forged Wheels	'14→'18	166801-17	165803-45	520	120	225,93
16489406	1000 S 1000 RR Forged Wheel #520 RLK (acciaio)	'14→'18	166801-17	164803RLK-45520		120	216,55
16489408	1000 S 1000 RR HP4 RACE	'17→'18	166801-17	165803-45	520	118	223,59
16589408	1000 S 1000 RR HP4 RACE #520 RLK (acciaio)	'17→'18	166801-17	164803RLK-45520		118	214,21
16489409	1000 S 1000 RR #520 RLK (acciaio)	'19→'20	166802-17	164601RLK-45520		120	211,12
16589409	1000 S 1000 RR #520 RACE	'19→'20	166802-17	165601-45	520	120	251,72
16589131	1000 S 1000 R (525 al)	'13→'20	166800-17	165800-45	525	120	238,29
16589241	1000 S 1000 RR (525 al)	'09→'11	166800-17	165800-44	525	118	233,07
16589242	1000 S 1000 RR (525 al)	'12→'14	166800-17	165800-45	525	118	235,87
16589244	1000 S 1000 RR (525 al)	'15→'18	166800-17	165800-45	525	120	238,29

BULTACO

4101601	50 50 Lobito	'99→'99	49102-12	41100-53	420	130	42,56
4101636	50 SM 50 Astro	'01	49102-13	41100-53	420	132	43,13

CAGIVA

4401241	50 50 Mito	'98→'99	49100-14	47102-52	420	132	47,68
4413603	125 125 K7	'89→'92	46203-13	44202-44	520	108	71,76
4413303	125 125 Mito	'90→'92	46203-14	44203-43	520	116	74,14
4413307	125 125 Mito	'08→'10	46203-14	44203-43	520	116	74,14
4413305	125 125 Mito Evo	'00→'03	46203-14	44203-38	520	112	65,77
4413304	125 125 Mito Evo	'92→'99	46203-14	44203-41	520	114	69,90
4413306	125 125 Mito Evo	'04→'07	46203-14	44203-43	520	116	74,14
4413131	125 125 Planet	'97→'98	46203-14	44203-43	520	116	74,14
4413133	125 125 Planet	'00→'03	46203-14	44203-43	520	116	74,14
4413134	125 125 Raptor	'03→'10	46203-14	44203-43	520	116	74,14
4413636	125 125 Super City	'91→'00	46203-13	44203-42	520	108	67,98
4413607	125 125 W8	'92→'95	46203-13	44202-44	520	108	71,76
4413605	125 125 W8	'96	46203-13	44202-46	520	110	73,51
4470161	600 600 River	'95→'99	22600-15	44203-43	520	116	120,69
4470500	600 W 16	'94→'98	22600-16	44202-44	520	112	119,18
4470501	600 W 16 >2G 100001	'94→'98	22600-15	44202-44	520	112	118,24
4473131	650 650 V-Raptor	'01→'07	28401-15	44501-45	525	108	127,20
4486554	900 900 ie Canyon	'98→'00	46604-15	44602-45	525	108	165,06
4486553	900 E 900 C Elefant	'93→'97	46603-15	44601-46	530	108	143,05
4486553	900 E 900 C ie Lucky Explorer	'95→'97	46603-15	44601-46	530	108	143,05
4486551	900 E 900 ie Elefant Dakar Replica	'90→'90	46602-14	44601-46	530	108	137,03
4486552	900 E 900 ie GT	'91→'92	46603-15	44601-48	530	110	147,99
4486552	900 E 900 ie Lucky Explorer	'91→'92	46603-15	44601-48	530	110	147,99



KIT AFAM / AFAM KIT

Codice Kit Code	Applicazione Application	Anno Year	Pignone F. Sprocket	Corona R. Sprocket	Passo Pitch	Mg. Nm	€
4489551	1000 1000 Navigator	'00→'05	28401-16	44602-41	525	108	176,86
4489131	1000 1000 Raptor	'00→'05	28400-16	44800-40	530	106	203,01
4489131	1000 X3 1000 Raptor	'03→'04	28400-16	44800-40	530	106	203,01

DAELIM

9211200	100 100 Altino	'96→'96	20200-14	10201-40	428	116	38,58
9213201	125 VC-S 125	'95→'97	20200-14	10223-43	428	126	37,42
9213200	125 VJ 125 Roadwin	'04→'06	20200-14	10223-42	428	130	37,74
9213202	125 VJ 125 Roadwin	'07→'13	20200-14	10223-45	428	130	39,28
16113241	125 VJF 125 Fi Roadsport	'08→'16	20200-14	10223-45	428	130	39,28
9213205	125 VJF 125 Fi Roadwin R	'08→'16	20200-14	10223-45	428	130	39,28
9213163	125 VL 125 Daystar	'01→'07	20200-14	10223-42	428	146	39,80
16113164	125 VL 125 Daystar II	'08→'14	20200-15	10223-45	428	148	42,15
9213165	125 VM 125 Solution	'06	20200-14	10223-42	428	126	37,21
9213161	125 VS 125	'98→'99	20200-14	10223-42	428	126	37,21
9213167	125 VS 125 Evolution	'00→'04	20200-14	10223-42	428	134	38,26
9213162	125 VT 125	'99→'03	20200-14	10223-42	428	134	38,26

DERBI

4701200	50 50 Fenix	'96→'98	49100-13	47101-48	420	122	69,31
4701602	50 50 R Senda R1	'00→'01	49102-13	47103-53	420	130	41,90
4701603	50 50 R Senda Racer	'01→'01	49102-12	47100-53	420	130	45,01
4701612	50 50 R Senda Racer	'02	49102-12	47100-53	420	130	45,01
4701611	50 50 R Senda Racer	'03	49102-13	47103-53	420	130	41,90
4701605	50 50 R Senda X Race	'04→'05	49102-13	47103-53	420	130	41,90
4701610	50 50 R Senda X Race	'06→'11	49102-11	47103-53	420	130	41,44
4701602	50 50 R Senda X-treme	'02→'03	49102-13	47103-53	420	130	41,90
4701611	50 50 R Senda X-treme	'05→'05	49102-13	47103-53	420	130	41,90
4701607	50 50 R Senda X-treme	'06→'12	49102-11	47103-53	420	130	41,44
4701601	50 50 Senda-R	'96→'99	49100-12	47100-53	420	130	47,08
4701602	50 50 Senda-R	'00→'02	49102-13	47103-53	420	130	41,90
4701636	50 50 SM Senda CLASSIC	'97→'98	49100-13	47100-53	420	130	47,39
4701638	50 50 SM Senda CLASSIC	'99→'02	49102-13	47100-53	420	130	45,33
4701652	50 50 SM Senda RACER	'02→'03	49102-13	47100-53	420	130	45,33
4701640	50 50 SM Senda X Race	'04→'05	49102-14	47103-53	420	130	42,56
4701646	50 50 SM Senda X Race	'06→'11	49102-11	47103-53	420	130	41,44
4701651	50 50 SM Senda X-treme	'02→'05	49102-14	47103-53	420	130	42,56
4701645	50 50 SM Senda X-treme	'06→'10	49102-11	47103-53	420	130	41,44
4701637	50 50 SM SM1	'00→'01	49102-14	47103-53	420	130	42,56
4701606	50 DRD 50 R Black devil edition	'04→'05	49102-13	41100-53	420	130	42,88
4701605	50 DRD 50 R Limited	'04→'05	49102-13	47103-53	420	130	41,90
4701608	50 DRD 50 R Limited Racing	'07→'08	49102-11	41100-53	420	130	42,42
4701609	50 DRD 50 R Senda Pro	'05→'16	49102-11	41100-53	420	132	42,67
4701604	50 DRD 50 R Senda Racing	'02→'05	49102-13	41100-53	420	130	42,88
4701608	50 DRD 50 R Senda Racing	'06→'13	49102-11	41100-53	420	130	42,42
4701614	50 50 R XTREME	'18→'20	49102-11	41100-59	420	134	46,07
4701613	50 DRD 50 X-TREME	'13→'17	49102-11	47103-53	420	130	41,44
4701641	50 DRD 50 SM Black devil edition	'04→'05	49102-14	41100-53	420	130	43,54
4701648	50 DRD 50 SM Senda Evo	'08→'11	49102-11	92114-53	420	130	42,42
4701644	50 DRD 50 SM Senda Limited	'04→'05	49102-14	92114-53	420	130	43,54
4701643	50 DRD 50 SM Senda Pro	'05→'16	49102-11	41100-53	420	132	42,67
4701639	50 DRD 50 SM Senda Racing	'02→'05	49102-14	41100-53	420	130	43,54
4701642	50 DRD 50 SM Senda Racing	'06→'10	49102-11	41100-53	420	130	42,42
4701649	50 DRD 50 SM Senda Racing	'11→'17	49102-11	92114-53	420	130	42,42
4701639	50 DRD 50 SM Senda Racing Limited	'05	49102-14	41100-53	420	130	43,54
4701642	50 DRD 50 SM Senda Racing Limited	'06	49102-11	41100-53	420	130	42,42
4701647	50 DRD 50 SM Senda Racing Limited	'07→'08	49102-11	92114-53	420	130	42,42
4701650	50 DRD 50 SM Senda X-treme	'11→'17	49102-11	92114-53	420	130	42,42
4701653	50 50 SM XTREME-RACING	'18→'20	49102-11	92114-59	420	134	51,92
4701639	50 DRD 50 SM Supermoto/Racer	'03→'04	49102-14	41100-53	420	130	43,54
4701245	50 GPR 50	'10→'13	49102-11	92114-53	420	130	42,42



KIT AFAM / AFAM KIT

Codice Kit Code	Applicazione Application	Anno Year	Pignone F. Sprocket	Corona R. Sprocket	Passo Pitch	Mg. Nm	€
4701241	50 GPR 50	'97→'00	49100-14	47102-52	420	132	47,68
4701243	50 GPR 50	'04→'05	49102-12	92114-53	420	132	42,81
4701244	50 GPR 50	'06→'09	49102-11	92114-53	420	132	42,67
4701131	50 GPR 50 Nude	'04→'05	49102-12	92114-53	420	132	42,81
4701132	50 GPR 50 Nude	'06→'09	49102-11	92114-53	420	132	42,67
4701245	50 GPR 50 Racing	'10→'13	49102-11	92114-53	420	130	42,42
4701244	50 GPR 50 Racing	'08→'09	49102-11	92114-53	420	132	42,67
4701241	50 GPR 50 Replica	'98→'00	49100-14	47102-52	420	132	47,68
4701242	50 GPR 50 Replica	'01	49102-14	47102-52	420	132	46,07
4701242	50 GPR 50 Replica Racing	'02→'03	49102-14	47102-52	420	132	46,07
4713552	125 125 Cross City	'07→'14	20200-15	47200-50	428	134	42,95
4713100	125 125 Mulhacen	'07→'10	49200-14	47200-51	428	130	47,22
4713101	125 125 Mulhacen Cafe	'08→'11	49200-14	92217-49	428	130	46,21
4713500	125 125 R Senda	'04→'05	20209-17	47200-54	428	142	53,03
4713501	125 125 R Senda Baja	'06→'12	20200-15	47200-51	428	134	48,30
4713636	125 125 SM Senda	'04→'07	20209-17	47200-50	428	138	43,90
4713638	125 125 SM Senda Baja	'06→'12	20200-15	47200-48	428	134	41,48
4713551	125 125 Terra Adventure	'07→'14	49200-14	47200-51	428	130	47,22
4713551	125 125 Terra Euro	'07→'13	49200-14	47200-51	428	130	47,22
4713502	125 DRD 125 R Senda	'10→'13	49200-14	47200-56	428	138	52,65
4713639	125 DRD 125 SM Senda	'09→'14	49200-14	47200-50	428	132	42,11
4713640	125 DRD 125 SM corona alluminio	'14→'15	49200-14	47202-49	428	132	46,45
4713241	125 GPR 125 4V	'09→'16	49200-14	47202-49	428	130	46,21
4713637	125 GPR 125 Nude	'04→'08	21202-16	47201-50	428	130	46,73
4713300	125 GPR 125 Racing	'04→'09	21202-16	47201-50	428	130	46,73
4726900	250 DXR	'05→'06	20317-14	92328-40	520	94	100,46
4726901	250 DXR	'04	20317-14	12502-40	520	94	100,46
4773100	659 659 Mulhacen	'06→'08	21510-15	14303-46	520	106	115,86
DUCATI							
5035241	350 350 Sport	'92→'92	52400-14	50602-45	520	96	105,81
5035241	350 350 SS	'93→'94	52400-14	50602-45	520	96	105,81
5043241	400 400 Supersport	'93→'97	52400-14	50602-43	520	98	104,48
5059200	500 500 Pantah	'79	52500-15	50600-38	530	94	108,33
5070161	600 600 Monster	'93→'94	52604-15	50602-38	520	98	114,81
5070162	600 600 Monster	'95→'97	52604-15	50602-43	520	100	123,52
5070163	600 600 Monster	'99→'01	52604-15	50602-46	520	102	126,08
5070163	600 600 Monster City (Dark)	'99	52604-15	50602-46	520	102	126,08
5070163	600 600 Monster Dark	'98→'99	52604-15	50602-46	520	102	126,08
5070200	600 600 Pantah	'81→'82	52500-15	50600-38	530	94	108,33
5070241	600 600 Supersport	'94	52604-15	50602-36	520	96	112,56
5070242	600 600 Supersport	'95→'98	52604-15	50602-41	520	100	119,74
5072161	620 620 ie Monster	'02→'04	52604-15	50602-46	520	106	128,53
5072162	620 620 Monster	'05→'06	52604-15	50602-48	520	106	131,29
5072161	620 620 Monster Dark	'03→'04	52604-15	50602-46	520	106	128,53
5072200	620 620 Multistrada	'05→'06	52604-15	50602-48	520	108	132,51
5072200	620 620 Multistrada Dark	'05→'06	52604-15	50602-48	520	108	132,51
5072241	620 620 S Supersport	'03	52604-15	50602-44	520	100	123,52
5075161	695 695 Monster	'06→'08	52604-15	50602-42	520	102	120,97
5075162	696 696 + Monster	'09→'12	52604-15	50602-45	520	108	129,75
5075162	696 696 + Monster ABS	'09→'12	52604-15	50602-45	520	108	129,75
5075162	696 696 Monster	'08→'14	52604-15	50602-45	520	108	129,75
5077242	748 748 Biposto	'95→'02	52610-14	50611-38	520	96	213,43
5077402	748 748 Biposto (for sprocket carrier PCD1)	'95→'02	52611-14	50607-38	520	96	115,75



KIT AFAM / AFAM KIT

Codice Kit Code	Applicazione Application	Anno Year	Pignone F. Sprocket	Corona R. Sprocket	Passo Pitch	Mg. Nm	€
5077242	748 748 R	'00→'02	52610-14	50611-38	520	96	213,43
5077402	748 748 R (for sprocket carrier PCD1)	'00→'02	52611-14	50607-38	520	96	115,75
5077242	748 748 S Biposto	'00→'02	52610-14	50611-38	520	96	213,43
5077402	748 748 S Biposto (for sprocket carrier PCD1)	'00→'02	52611-14	50607-38	520	96	115,75
5077242	748 748 S Monoposto	'00→'02	52610-14	50611-38	520	96	213,43
5077402	748 748 S Monoposto (for sprocket carrier PCD1)	'00→'02	52611-14	50607-38	520	96	115,75
5077241	748 748 SP	'95→'98	52610-14	50611-37	520	94	212,21
5077242	748 748 SP Monoposto	'99→'02	52610-14	50611-38	520	96	213,43
5077402	748 748 SP Monoposto (for sprocket carrier PCD1)	'99→'02	52611-14	50607-38	520	96	115,75
5077241	748 748 SPS	'98→'99	52610-14	50611-37	520	94	212,21
5077242	748 748 Testa Bassa	'01	52610-14	50611-38	520	96	213,43
5077402	748 748 Testa Bassa (for sprocket carrier PCD1)	'01→'01	52611-14	50607-38	520	96	115,75
5077248	749 749 Dark	'04→'06	52613-14	50612-39	525	98	121,00
5077248	749 749 Monoposto/Biposto	'03→'06	52613-14	50612-39	525	98	121,00
5077248	749 749 R	'04→'06	52613-14	50612-39	525	98	121,00
5077248	749 749 S	'03→'07	52613-14	50612-39	525	98	121,00
5077163	750 750 ie Monster	'02	52604-15	50602-41	520	102	120,97
5077247	750 750 IE Supersport	'99→'02	52604-15	50602-40	520	98	117,40
5077161	750 750 Monster	'96→'98	52604-15	50602-38	520	98	114,81
5077162	750 750 Monster	'00→'01	52604-15	50602-41	520	100	119,74
5077163	750 750 Monster	'02	52604-15	50602-41	520	102	120,97
5077162	750 750 Monster (Dark)	'99	52604-15	50602-41	520	100	119,74
5077162	750 750 Monster City (Dark)	'99	52604-15	50602-41	520	100	119,74
5077243	750 750 Paso	'87→'88	52606-15	50601-38	520	106	108,72
5077246	750 750 Supersport	'91→'98	52604-15	50602-37	520	96	113,58
5077247	750 750 Supersport	'99	52604-15	50602-40	520	98	117,40
5077247	750 750 Supersport Sport	'01→'02	52604-15	50602-40	520	98	117,40
5080636	796 796 Hypermotard	'10→'12	52616-15	50800-41	525	104	266,56
5080163	796 796 Monster	'10→'13	52616-15	50800-39	525	104	265,76
5080402	796 796 Monster (for sprocket carrier PCD2)	'10→'13	52616-15	50608-39	525	104	157,71
5080163	796 796 Monster ABS	'10→'14	52616-15	50800-39	525	104	265,76
5080402	796 796 Monster ABS (for sprocket carrier PCD2)	'10→'14	52616-15	50608-39	525	104	157,71
5080165	797 797 + Monster	'18	52604-15	50613-46	520	104	159,64
5080165	797 797 Monster	'17→'18	52604-15	50613-46	520	104	159,64
5080161	800 800 Monster	'03→'04	52610-15	50602-42	520	102	149,70
5080164	800 800 Monster Dark	'03	52610-15	50602-42	520	102	149,70
5080241	800 800 S Supersport	'03	52607-15	50602-39	520	98	136,68
5080162	800 800 S2R Monster	'05→'07	52604-15	50614-41	520	104	250,89
5080403	800 800 S2R Monster (for sprocket carrier PCD2)	'05→'07	52604-15	50607-41	520	104	154,53
5080162	800 800 S2R Monster Dark	'05→'06	52604-15	50614-41	520	104	250,89
5080403	800 800 S2R Monster Dark (for sprocket carrier PCD2)	'05→'06	52604-15	50607-41	520	104	154,53
5080241	800 800 Supersport	'03→'05	52607-15	50602-39	520	98	136,68
5080100	803 803 Scrambler Caf, Racer	'17→'18	52604-15	50613-46	520	104	188,37
5080100	803 803 Scrambler Classic	'15→'18	52604-15	50613-46	520	104	188,37
5080100	803 803 Scrambler Flat Track Pro	'16	52604-15	50613-46	520	104	188,37
5080100	803 803 Scrambler Full Throttle	'15→'18	52604-15	50613-46	520	104	188,37
5080100	803 803 Scrambler Icon	'15→'18	52604-15	50613-46	520	104	188,37
5080100	803 803 Scrambler Mach 2	'18	52604-15	50613-46	520	104	188,37
5080100	803 803 Scrambler Street Classic	'18	52604-15	50613-46	520	104	188,37
5080100	803 803 Scrambler Urban Enduro	'15→'16	52604-15	50613-46	520	104	188,37
5080101	803 Desert Sled	'17→'20	52604-15	50613-46	520	108	193,06
5081636	821 821 Hypermotard	'13→'15	52613-15	50800-45	525	108	266,53
5081200	821 821 Hyperstrada	'13→'15	52613-15	50800-45	525	108	266,53
5081161	821 821 Monster	'14→'18	52619-15	50613-46	520	108	190,51
5081161	821 821 Monster Dark	'15→'18	52619-15	50613-46	520	108	190,51
5081161	821 821 Monster Stripe	'15→'18	52619-15	50613-46	520	108	190,51



KIT AFAM / AFAM KIT

Codice Kit Code	Applicazione Application	Anno Year	Pignone F. Sprocket	Corona R. Sprocket	Passo Pitch	Mg. Nm	€
5081636	821 821 SP Hypermotard	'13→'15	52613-15	50800-45	525	108	266,53
5083250	848 848	'08→'10	52613-15	50800-39	525	98	252,74
5083402	848 848 EVO (for sprocket carrier PCD2) #520	'07→'13	52614-15	50607-39	520	98	168,63
5083401	848 848 (for sprocket carrier PCD2)	'08→'10	52613-15	50608-39	525	98	144,69
5083250	848 848 Evo	'10→'13	52613-15	50800-39	525	98	252,74
5083401	848 848 Evo (for sprocket carrier PCD2)	'10→'13	52613-15	50608-39	525	98	144,69
5083250	848 848 Evo Dark	'12	52613-15	50800-39	525	98	252,74
5083401	848 848 Evo Dark (for sprocket carrier PCD2)	'12	52613-15	50608-39	525	98	144,69
5083250	848 848 SE Evo Corse	'12→'13	52613-15	50800-39	525	98	252,74
5083401	848 848 SE Evo Corse (for sprocket carrier PCD2)	'12→'13	52613-15	50608-39	525	98	144,69
5083131	848 848 Streetfighter	'11→'15	52613-15	50800-42	525	104	259,21
5083244	851 851 SP1 Superbike Biposto	'88→'89	52604-15	50601-38	520	98	142,42
5083245	851 851 SP2 Superbike Biposto	'90	52604-15	50602-39	520	98	145,01
5083246	851 851 SP3 Superbike Biposto	'91	52604-15	50602-37	520	98	142,42
5083249	851 851 SP4 Superbike Biposto	'92	52604-15	50602-36	520	98	141,40
5083241	851 851 Sport	'88	52604-15	50601-38	520	98	142,42
5083242	851 851 Sport	'89→'91	52604-15	50602-39	520	98	145,01
5083247	851 851 Strada	'92	52604-15	50602-39	520	98	145,01
5083251	851 851 Strada	'93→'94	52604-15	50602-36	520	98	141,40
5083243	888 888 SP4 Superbike Strada	'92	52604-15	50602-36	520	96	139,62
5083243	888 888 SP5 Superbike Strada	'93→'95	52604-15	50602-36	520	96	139,62
5086246	899 899 Panigale	'14→'15	52618-15	50613-44	520	106	186,52
5086161	900 900 IE Monster	'00→'01	52612-15	50602-38	520	98	170,07
5086164	900 900 IE Monster	'02	52612-15	50602-38	520	100	172,41
5086161	900 900 IE Monster Dark	'00→'01	52612-15	50602-38	520	98	170,07
5086165	900 900 Monster	'93→'99	52604-15	50602-39	520	98	172,07
5086165	900 900 Monster City (Dark)	'99	52604-15	50602-39	520	98	172,07
5086165	900 900 Monster Cromo	'98	52604-15	50602-39	520	98	172,07
5086243	900 900 Supersport	'89→'90	52604-15	50602-39	520	98	172,07
5086245	900 900 Supersport	'98→'02	52604-15	50602-40	520	96	143,23
5086245	900 900 Supersport Sport	'02	52604-15	50602-40	520	96	143,23
5086244	900 900 Supersport/Superlight	'91→'97	52604-15	50602-37	520	96	140,64
5086205	906 906 Paso	'90→'91	52604-15	50601-38	520	106	149,60
5086203	906 906 Paso	'88→'89	52604-15	50601-40	520	108	153,97
5086204	907 907 IE	'90→'93	52607-15	50602-40	520	108	145,64
5086241	916 916 Biposto	'94→'98	52608-15	50605-36	525	94	252,99
5086162	916 916 S4 Monster	'01→'03	52608-15	50609-37	525	100	150,40
5086162	916 916 S4 Monster Foggy	'02	52608-15	50609-37	525	100	150,40
5086247	916 916 Senna	'94→'96	52608-15	50605-36	525	94	252,99
5086248	916 916 SP	'94→'97	52608-15	50605-36	525	94	252,99
5086241	916 916 SP	'98	52608-15	50605-36	525	94	252,99
5087201	916 916 ST4	'99→'02	52608-15	50609-43	525	102	160,34
5087636	939 939 Hypermotard	'16→'18	52613-15	50800-43	525	106	292,78
5087204	939 939 Hyperstrada	'16	52613-15	50800-43	525	106	292,78
5087403	939 Hypermotard (for sprocket carrier PCD2)	'16→'19	52613-15	50608K-43	525	106	189,71
5087404	939 Hyperstrada (for sprocket carrier PCD2)	'16→'17	52613-15	50608K-43	525	106	189,71
5087242	939 939 S Supersport	'17→'18	52619-15	50806-43	520	106	302,06
5087636	939 939 SP Hypermotard	'16→'18	52613-15	50800-43	525	106	292,78
5087200	944 944 ST2	'97→'03	52608-15	50609-42	525	102	156,24
5087637	950 Hypermotard 2019-2020	'19→'20	52619-15	50614-43	525	102	284,63
5087551	950 950 Multistrada	'17→'18	52616-15	50807-43	525	114	207,38
5087552	950 Monster - Strada	'19→'20	52800-15	50807-43	525	114	199,15



KIT AFAM / AFAM KIT

Codice Kit Code	Applicazione Application	Anno Year	Pignone F. Sprocket	Corona R. Sprocket	Passo Pitch	Mg. Nm	€
5087243	955 955 Panigale V2	'20	52902-15	50806-43	520	106	297,82
5087405	955 V2 Panigale (for sprocket carrier PCD5)	'20	52902-15	50804K-43	520	106	181,34
5087241	959 959 Panigale	'16→'18	52618-15	50613-43	520	106	186,52
5087241	959 959 Panigale Corse	'18	52618-15	50613-43	520	106	186,52
5087203	992 992 ST3	'04→'07	52613-15	50609-42	525	102	149,77
5087203	992 992 ST3 ABS	'06→'07	52613-15	50609-42	525	102	149,77
5089240	996 996 Monoposto/Biposto	'99→'01	52608-15	50605-36	525	94	278,68
5089243	996 996 R	'01	52613-15	50605-36	525	94	272,20
5089240	996 996 S	'01	52608-15	50605-36	525	94	278,68
5087161	996 996 S4R Monster	'03→'06	52608-15	50800-42	525	104	294,15
5089240	996 996 SPS	'97→'99	52608-15	50605-36	525	94	278,68
5087202	996 996 ST4S	'01→'05	52608-15	50609-38	525	100	177,77
5087202	996 996 ST4S ABS	'03→'05	52608-15	50609-38	525	100	177,77
5089241	998 998 Matrix	'04	52613-15	50605-36	525	94	246,51
5089241	998 998 Monoposto/Biposto	'02→'03	52613-15	50605-36	525	94	246,51
5089241	998 998 R	'02	52613-15	50605-36	525	94	246,51
5089241	998 998 S	'02→'04	52613-15	50605-36	525	94	246,51
5089241	998 998 S Bayliss/Bostrom	'02	52613-15	50605-36	525	94	246,51
5087162	998 998 S4R Monster Testastretta	'07→'08	52613-15	50800-43	525	104	261,87
5087162	998 998 S4RS Monster Testastretta	'06→'08	52613-15	50800-43	525	104	261,87
5087162	998 998 S4RS Monster Testastretta Tricolore	'08	52613-15	50800-43	525	104	261,87
5089242	999 999	'03→'06	52613-15	50612-36	525	96	165,31
5089242	999 999 R	'03→'06	52613-15	50612-36	525	96	165,31
5089242	999 999 R Fila	'03	52613-15	50612-36	525	96	165,31
5089242	999 999 R Xerox	'06	52613-15	50612-36	525	96	165,31
5089242	999 999 S	'03→'04	52613-15	50612-36	525	96	165,31
5089242	999 999 S Monoposto/Biposto	'05→'06	52613-15	50612-36	525	96	165,31
5089201	1000 1000 DS Multistrada	'03→'05	52613-15	50800-42	525	104	287,67
5089200	1000 1000 DS Supersport	'05→'06	52613-15	50609-38	525	96	166,43
5089131	1000 1000 GT	'06→'10	52613-15	50609-39	525	100	173,95
5089131	1000 1000 GT Touring	'09	52613-15	50609-39	525	100	173,95
5089161	1000 1000 ie Monster	'04→'05	52613-15	50609-39	525	100	173,95
5089132	1000 1000 LE Paul Smart	'06→'08	52613-15	50609-39	525	100	173,95
5089161	1000 1000 Monster	'03	52613-15	50609-39	525	100	173,95
5089161	1000 1000 S ie Monster	'03→'05	52613-15	50609-39	525	100	173,95
5089131	1000 1000 S Sport	'07→'09	52613-15	50609-39	525	100	173,95
5089162	1000 1000 S2R Monster	'06→'08	52613-15	50800-41	525	104	287,67
5089405	1000 Monster S2R (for sprocket carrier PCD2)	'06→'08	52613-15	50608K-41	525	104	183,16
5089131	1000 1000 Sport Classic	'06→'08	52613-15	50609-39	525	100	173,95
5089200	1000 1000 SS Supersport	'03→'04	52613-15	50609-38	525	96	166,43
5089201	1000 S 1000 DS Multistrada	'05→'06	52613-15	50800-42	525	104	287,67
5092241	1098 1098	'07	52613-15	50801-38	525	98	277,80
5092242	1098 1098	'08	52613-15	50801-38	525	98	277,80
5092242	1098 1098 R	'08→'09	52613-15	50801-38	525	98	277,80
5092242	1098 1098 S	'07→'08	52613-15	50801-38	525	98	277,80
5092242	1098 1098 S Tricolore	'07	52613-15	50801-38	525	98	277,80
5092402	1098 1098 (for sprocket carrier PCD2) #520 steel	'07→'08	52614-15	50804K-38	520	98	166,01
5092637	1100 1100 Evo Hypermotard	'10→'12	52613-15	50800-41	525	104	287,67
5092636	1100 1100 Hypermotard	'07→'09	52613-15	50800-42	525	104	287,67
5092161	1100 1100 Monster	'09→'10	52613-15	50800-39	525	104	286,87
5092409	1100 1100 Monster (for sprocket carrier PCD2)	'09→'10	52613-15	50608-39	525	104	178,82



KIT AFAM / AFAM KIT

Codice Kit Code	Applicazione Application	Anno Year	Pignone F. Sprocket	Corona R. Sprocket	Passo Pitch	Mg. Nm	€
5092161	1100 1100 Monster ABS	'09→'10	52613-15	50800-39	525	104	286,87
5092409	1100 1100 Monster ABS (for sprocket carrier PCD2)	'09→'10	52613-15	50608-39	525	104	178,82
5092162	1100 1100 Monster Diesel	'13	52613-15	50800-39	525	104	286,87
5092411	1100 1100 Monster Diesel (for sprocket carrier PCD2)	'13	52613-15	50608-39	525	104	178,82
5092162	1100 1100 Monster Evo	'11→'13	52613-15	50800-39	525	104	286,87
5092411	1100 1100 Monster Evo (for sprocket carrier PCD2)	'11→'13	52613-15	50608-39	525	104	178,82
5092201	1100 1100 Multistrada	'07→'09	52613-15	50800-42	525	104	287,67
5092636	1100 1100 S Hypermotard	'07→'09	52613-15	50800-42	525	104	287,67
5092161	1100 1100 S Monster	'09→'10	52613-15	50800-39	525	104	286,87
5092409	1100 1100 S Monster (for sprocket carrier PCD2)	'09→'10	52613-15	50608-39	525	104	178,82
5092161	1100 1100 S Monster ABS	'09→'10	52613-15	50800-39	525	104	286,87
5092409	1100 1100 S Monster ABS (for sprocket carrier PCD2)	'09→'10	52613-15	50608-39	525	104	178,82
5092201	1100 1100 S Multistrada	'07→'09	52613-15	50800-42	525	104	287,67
5092131	1100 1100 S Streetfighter	'09→'13	52613-15	50801-38	525	102	282,70
5092637	1100 1100 SP Evo Hypermotard	'10→'12	52613-15	50800-41	525	104	287,67
5092100	1100 Scrambler	'18→'20	52619-15	50613-39	520	104	179,62
5092131	1100 1100 Streetfighter	'09→'10	52613-15	50801-38	525	102	282,70
5092243	1100 V4 1100	'18	52901-16	50901-41	525	114	301,14
5092413	1100 V4 1100 S (for sprocket carrier PCD4) # 520	'18→'20	52902-16	50804K-41	520	114	189,85
5092243	1100 V4 1100 S	'18	52901-16	50901-41	525	114	301,14
5092243	1100 V4 1100 Speciale	'18	52901-16	50901-41	525	114	301,14
5092132	1103 Streetfighter V4	'20	52901-15	50901-42	525	116	303,52
5092415	1103 Streetfighter V4 (for sprocket carrier PCD4) # 525	'20	52901-15	50803K-42	525	116	197,50
5092414	1103 V4 S 19-20 RACE	'19→'20	52902-15	50804K-42	520	114	188,24
5095241	1198 1198	'09→'11	52613-15	50801-38	525	98	277,80
5095241	1198 1198 R Corse	'10	52613-15	50801-38	525	98	277,80
5095241	1198 1198 S	'09→'10	52613-15	50801-38	525	98	277,80
5095241	1198 1198 S Corse	'10	52613-15	50801-38	525	98	277,80
5095241	1198 1198 SP	'11	52613-15	50801-38	525	98	277,80
5095402	1198 1198 S/R (for sprocket carrier PCD3) #520	'09→'11	52614-15	50804K-38	520	98	177,73
5095242	1199 1199 Panigale	'12→'13	52901-15	50901-39	525	104	286,59
5095407	1199 1199 Panigale R (for sprocket carrier PCD4) #520	'13→'17	52902-15	50804K-41	520	106	178,85
5095242	1199 1199 Panigale ABS	'12→'14	52901-15	50901-39	525	104	286,59
5095243	1199 1199 Panigale R	'13→'15	52901-15	50901-41	525	106	289,84
5095242	1199 1199 Panigale S	'14	52901-15	50901-39	525	104	286,59
5095242	1199 1199 Panigale S ABS	'12→'13	52901-15	50901-39	525	104	286,59
5095242	1199 1199 Panigale S Tricolore	'12→'14	52901-15	50901-39	525	104	286,59
5095243	1199 1199 Superleggera	'14	52901-15	50901-41	525	106	289,84
5095131	1200 1200 Diavel	'11→'18	52613-15	50801-43	525	118	307,37
5095131	1200 1200 Diavel AMG	'12→'13	52613-15	50801-43	525	118	307,37
5095131	1200 1200 Diavel Carbon	'14→'18	52613-15	50801-43	525	118	307,37
5095131	1200 1200 Diavel Carbon ABS	'11→'13	52613-15	50801-43	525	118	307,37
5095131	1200 1200 Diavel Chromo	'13→'14	52613-15	50801-43	525	118	307,37
5095131	1200 1200 Diavel Chromo ABS	'12	52613-15	50801-43	525	118	307,37
5095131	1200 1200 Diavel Dark	'14	52613-15	50801-43	525	118	307,37
5095131	1200 1200 Diavel Dark ABS	'13	52613-15	50801-43	525	118	307,37
5095131	1200 1200 Diavel Diesel	'17→'18	52613-15	50801-43	525	118	307,37
5095131	1200 1200 Diavel Strada	'14	52613-15	50801-43	525	118	307,37
5095131	1200 1200 Diavel Strada ABS	'13	52613-15	50801-43	525	118	307,37
5095161	1200 1200 Monster	'14→'18	52613-15	50901-41	525	108	292,57



KIT AFAM / AFAM KIT

Codice Kit Code	Applicazione Application	Anno Year	Pignone F. Sprocket	Corona R. Sprocket	Passo Pitch	Mg. Nm	€
5095200	1200 1200 Multistrada	'10→'12	52900-15	50900-40	530	108	327,99
5095200	1200 1200 Multistrada ABS	'10→'14	52900-15	50900-40	530	108	327,99
5095200	1200 1200 Multistrada DVT	'15→'17	52900-15	50900-40	530	108	327,99
5095551	1200 1200 Multistrada Enduro	'16→'18	52900-15	50902-43	530	114	236,88
5095551	1200 1200 Multistrada Enduro Pro	'18	52900-15	50902-43	530	114	236,88
5095200	1200 1200 Multistrada Touring Edition ABS	'11→'12	52900-15	50900-40	530	108	327,99
5095161	1200 1200 R Monster	'14→'19	52613-15	50901-41	525	108	292,57
5095411	1200 1200 R Monster (for sprocket carrier PCD4)	'14→'19	52613-15	50803K-41	525	108	188,06
5095161	1200 1200 S Monster	'14→'18	52613-15	50901-41	525	108	292,57
5095161	1200 1200 S Monster Stripe	'15	52613-15	50901-41	525	108	292,57
5095200	1200 1200 S Multistrada	'10→'12	52900-15	50900-40	530	108	327,99
5095200	1200 1200 S Multistrada D Air DVT	'15→'17	52900-15	50900-40	530	108	327,99
5095200	1200 1200 S Multistrada DVT	'15→'17	52900-15	50900-40	530	108	327,99
5095200	1200 1200 S Multistrada Granturismo	'13→'14	52900-15	50900-40	530	108	327,99
5095200	1200 1200 S Multistrada Pikes Peak	'16→'16	52900-15	50900-40	530	108	327,99
5095200	1200 1200 S Multistrada Sports Edition	'10→'14	52900-15	50900-40	530	108	327,99
5095200	1200 1200 S Multistrada Touring Edition	'10→'14	52900-15	50900-40	530	108	327,99
5095200	1200 1200 SE Multistrada Pikes Peak	'11→'17	52900-15	50900-40	530	108	327,99
5097131	1260 DIAVEL 1260	'19→'20	52613-15	50801-43	525	112	300,10
5097200	1260 1260 Multistrada	'18→'20	52900-15	50900-40	530 →'	114	336,66
5097551	1260 1260 Multistrada enduro 2019-2020	'19→'20	52900-15	50902-43	530	114	236,87
5097241	1299 1299 R Panigale	'17	52901-15	50901-39	525	104	286,59
5097241	1299 1299 S Panigale	'15→'17	52901-15	50901-39	525	104	286,59
5097241	1299 1299 Superleggera	'15→'17	52901-15	50901-39	525	104	286,59
5097242	1299 1299 Panigale Superleggera	'17→'17	52901-15	50901-39	525	106	289,02
5097403	1299 1299 Superleggera (for sprocket carrier PCD4) #525	'17	52901-15	50803K-39	525	106	184,02
DUCATI CORONE ALLUMINIO + TRASFORMAZIONE # 520							
5177402	748 748 Biposto (for sprocket carrier PCD1)	'95→'02	52611-14	51607-38	520	96	165,03
5177402	748 748 R (for sprocket carrier PCD1)	'00→'02	52611-14	51607-38	520	96	165,03
5177402	748 748 S Biposto (for sprocket carrier PCD1)	'00→'02	52611-14	51607-38	520	96	165,03
5177402	748 748 S Monoposto (for sprocket carrier PCD1)	'00→'02	52611-14	51607-38	520	96	165,03
5177401	748 748 SP (for sprocket carrier PCD1)	'95→'98	52611-14	51607-37	520	94	162,30
5177402	748 748 SP Monoposto (for sprocket carrier PCD1)	'99→'02	52611-14	51607-38	520	96	165,03
5177401	748 748 SPS (for sprocket carrier PCD1)	'98→'99	52611-14	51607-37	520	94	162,30
5177402	748 748 Testa Bassa (for sprocket carrier PCD1)	'01	52611-14	51607-38	520	96	165,03
5177403	749 749 Dark	'04→'06	52614-14	51613-39	520	98	187,68
5177403	749 749 Monoposto/Biposto	'03→'06	52614-14	51613-39	520	98	187,68
5177403	749 749 R	'04→'06	52614-14	51613-39	520	98	187,68
5177403	749 749 S	'03→'07	52614-14	51613-39	520	98	187,68
5180403	800 800 S2R Monster (for sprocket carrier PCD2)	'05→'07	52604-15	51607-41	520	104	205,21
5180403	800 800 S2R Monster Dark (for sprocket carrier PCD2)	'05→'06	52604-15	51607-41	520	104	205,21
5183402	848 848 (for sprocket carrier PCD2)	'08→'10	52614-15	51607-39	520	98	188,83
5183402	848 848 Evo (for sprocket carrier PCD2)	'10→'13	52614-15	51607-39	520	98	188,83
5183402	848 848 Evo Dark (for sprocket carrier PCD2)	'12	52614-15	51607-39	520	98	188,83
5183402	848 848 SE Evo Corse (for sprocket carrier PCD2)	'12→'13	52614-15	51607-39	520	98	188,83
5187403	939 939 Hypermotard (for sprocket carrier PCD2)	'16→'19	52613-15	51608-43	525	106	188,92



KIT AFAM / AFAM KIT

Codice Kit Code	Applicazione Application	Anno Year	Pignone F. Sprocket	Corona R. Sprocket	Passo Pitch	Mg. Nm	€
5187404	939 939 Hyperstrada (for sprocket carrier PCD2)	'16→'17	52613-15	51608-43	525	106	188,92
5187405	955 V2 Panigale (for sprocket carrier PCD5)	'20	52902-15	51804-43	520	106	204,27
5187241	959 959 Panigale	'16→'18	52618-15	51613-43	520	106	210,29
5187241	959 959 Panigale Corse	'18	52618-15	51613-43	520	106	210,29
5189241	996 996 R/998 S 01-02 (for sprocket carrier PCD2) #525	'01→'02	52613-15	51608-37	525	94	165,75
5192414	1000 1000 Panigale V4 R RACE	'19→'20	52902-15	51804-42	520	114	212,98
5192402	1098 1098 (for sprocket carrier PCD3)	'07→'07	52614-15	51804-38	520	98	188,24
5192402	1098 1098 (for sprocket carrier PCD3)	'08	52614-15	51804-38	520	98	188,24
5192402	1098 1098 R (for sprocket carrier PCD3)	'08→'09	52614-15	51804-38	520	98	188,24
5192402	1098 1098 S (for sprocket carrier PCD3)	'07→'08	52614-15	51804-38	520	98	188,24
5192402	1098 1098 S Tricolore (for sprocket carrier PCD3)	'07	52614-15	51804-38	520	98	188,24
5192407	1100 1100 Hypermotard (for sprocket carrier PCD2)	'07→'09	52614-15	51607-42	520	104	201,53
5192405	1100 1100 Multistrada (for sprocket carrier PCD2)	'07→'09	52614-15	51607-42	520	104	201,53
5192407	1100 1100 S Hypermotard (for sprocket carrier PCD2)	'07→'09	52614-15	51607-42	520	104	201,53
5192405	1100 1100 S Multistrada (for sprocket carrier PCD2)	'07→'09	52614-15	51607-42	520	104	201,53
5192413	1100 V4 1100 (for sprocket carrier PCD4)	'18	52902-16	51804-41	520	114	211,79
5192413	1100 V4 1100 S (for sprocket carrier PCD4)	'18	52902-16	51804-41	520	114	211,79
5192413	1100 V4 1100 Speciale (for sprocket carrier PCD4)	'18	52902-16	51804-41	520	114	211,79
5195402	1198 1198 (for sprocket carrier PCD3)	'09→'11	52614-15	51804-38	520	98	188,24
5195402	1198 1198 R Corse (for sprocket carrier PCD3)	'10	52614-15	51804-38	520	98	188,24
5195402	1198 1198 S (for sprocket carrier PCD3)	'09→'10	52614-15	51804-38	520	98	188,24
5195402	1198 1198 S Corse (for sprocket carrier PCD3)	'10	52614-15	51804-38	520	98	188,24
5195402	1198 1198 SP (for sprocket carrier PCD3)	'11	52614-15	51804-38	520	98	188,24
5195405	1199 1199 Panigale (for sprocket carrier PCD4)	'12→'13	52902-15	51804-39	520	104	195,58
5195405	1199 1199 Panigale ABS (for sprocket carrier PCD4)	'12→'14	52902-15	51804-39	520	104	195,58
5195407	1199 1199 Panigale R (for sprocket carrier PCD4)	'13→'15	52902-15	51804-41	520	106	200,80
5195405	1199 1199 Panigale S (for sprocket carrier PCD4)	'14	52902-15	51804-39	520	104	195,58
5195405	1199 1199 Panigale S ABS (for sprocket carrier PCD4)	'12→'13	52902-15	51804-39	520	104	195,58
5195405	1199 1199 Panigale S Tricolore (for sprocket carrier PCD4)	'12→'14	52902-15	51804-39	520	104	195,58
5195407	1199 1199 Superleggera (for sprocket carrier PCD4)	'14→'14	52902-15	51804-41	520	106	200,80
5197402	1299 1299 Panigale (for sprocket carrier PCD4)	'15→'17	52902-15	51804-39	520	104	195,58
5197402	1299 1299 R Panigale (for sprocket carrier PCD4)	'17	52902-15	51804-39	520	104	195,58
5197402	1299 1299 S Panigale (for sprocket carrier PCD4)	'15→'17	52902-15	51804-39	520	106	197,92
5197402	1299 1299 Superleggera (for sprocket carrier PCD4)	'17	52902-15	51804-39	520	106	197,92



KIT AFAM / AFAM KIT

Codice Kit Code	Applicazione Application	Anno Year	Pignone F. Sprocket	Corona R. Sprocket	Passo Pitch	Mg. Nm	€
GILERA							
5601162	50 50 Eaglet	'96	58102-12	56102-46	420	132	45,09
5601602	50 50 Surfer	'98→'00	58102-12	56103-46	420	124	44,07
5601603	50 50 Zulu	'01→'02	49102-12	56103-46	420	124	41,09
5601241	50 GP 50	'02→'03	49102-12	47102-52	420	132	45,09
5601602	50 GSM 50	'00	58102-12	56103-46	420	124	44,07
5601603	50 GSM 50	'01→'03	49102-12	56103-46	420	124	41,09
5601602	50 H@K 50	'00	58102-12	56103-46	420	124	44,07
5601603	50 H@K 50	'01→'02	49102-12	56103-46	420	124	41,09
5601639	50 SMT 50 Racing	'11→'14	49102-11	92114-53	420	130	42,42
5601636	50 SMT 50 Supermotard	'03→'05	49102-14	47103-53	420	130	42,56
5601637	50 SMT 50 Supermotard	'06→'10	49102-11	47103-53	420	130	41,44
5601638	50 SMT 50 Supermotard	'11→'16	49102-11	92114-53	420	130	42,42
5613302	125 SP-01 / SP-02	'88→'92	58202-14	10215-38	520	104	77,95
5613161	125 125 Coguar	'99→'02	26200-17	59207-48	428	134	45,99
5613637	125 125 Freestyle	'91→'93	58201-13	10215-44	520	108	84,08
5613601	125 125 XR2	'90→'93	58201-13	35202-44	520	106	83,62
5613303	125 SC 125	'06→'07	21202-16	47201-50	428	130	46,73
5670636	600 600 Northwest	'91→'94	58500-14	56501-43	520	108	142,42
5670600	600 XRT 600	'88→'89	58500-14	35304-43	520	106	127,02
HARLEY DAVIDSON							
9286161	883 XLH 883 4 speed Sportster	'86→'90	94802-21	92803-48	530	108	160,27
9286162	883 XLH 883 5 speed Sportster	'91→'92	94602-21	92803-48	530	108	167,31
9295162	1200 1200 4 speed Sportster	'86→'90	94802-21	92803-40	530	104	146,66
9295163	1200 1200 5 speed Sportster	'91→'92	94602-21	92803-40	530	104	153,69
HM-HONDA							
11001639	50 CRE 50 RR Derapage	'08	94121-11	47200-60	428	140	57,015
11001637	50 CRM 50 Derapage	'03→'13	94121-11	47200-60	428	140	57,015
11001637	50 CRM 50 Derapage	'14→'16	94121-11	47200-60	428	140	57,015
11001639	50 CRM 50 Derapage Competition	'11→'12	94121-11	47200-60	428	140	57,015
11001639	50 CRM 50 RR Derapage	'07→'16	94121-11	47200-60	428	140	57,015
11013638	125 CRM 125 RR Derapage 2T	'11→'16	61201-16	14206-46	520	112	72,45
11013638	125 CRM 125 RR Derapage Comp. 2T	'11→'16	61201-16	14206-46	520	112	72,45
11013639	125 CRM F 125 4T	'11→'16	21208-14	47200-58	428	140	54,81
11013637	125 CRM F 125 RR 4T	'11→'16	21208-14	47200-58	428	140	54,81
11013636	125 CRM F X 125	'09→'11	21208-14	10228-58	428	140	54,81
HM-HONDA CORONE ALLUMINIO							
9301600	50 CRE 50 BAJA	'03→'16	94121-14	48200-62	428	140	97,27
9301636	50 CRE 50 Derapage	'02	94118-13	60104-56	428	140	80,85
11101639	50 CRE 50 RR Derapage	'08	94121-11	48200-60	428	140	88,45
9301637	50 CRM 50 Derapage	'03	94121-11	48200-60	428	140	88,45
9301638	50 CRM 50 Derapage Competition	'04→'10	94121-14	48200-58	428	140	86,07
11101639	50 CRM 50 RR Derapage	'07→'16	94121-11	48200-60	428	140	88,45
11113639	125 CRM F 125 4T	'11→'16	21208-14	48200-58	428	140	83,06
HONDA							
1001104	50 C 50 Z	'75→'80	20104-13	10105-40	420	98	35,60
1001200	50 CB 50 J	'77→'81	20101-13	10106-42	420	104	41,02
1001106	50 CF 50 Chaly	'79→'94	20101-14	10106-38	420	88	36,86
1001201	50 MB 5 S	'80→'82	20104-14	10103-42	420	106	37,49
1001202	50 MBX 50 S D,E,F	'83→'85	20104-14	10103-42	420	118	38,99
1001601	50 MT 50 S A,B,C,D,E,F,G,H,J,K,L,M,N,P	'80→'93	20104-13	10103-42	420	106	37,35
1001600	50 MTX 50	'84→'87	20100-14	10103-42	420	124	39,76
1001602	50 MTX 50 R	'83→'83	20104-13	10103-47	420	126	42,49



KIT AFAM / AFAM KIT

Codice Kit Code	Applicazione Application	Anno Year	Pignone F. Sprocket	Corona R. Sprocket	Passo Pitch	Mg. Nm	€
1001243	50 NSR 50 S K,L,M,N,P,R,S	'89→'95	20104-12	10100-45	420	124	41,20
1001203	50 SS 50 ZB2	'77→'80	20104-12	10106-42	420	98	40,85
1001203	50 SS 50 ZK2	'75→'77	20104-12	10106-42	420	98	40,85
1001105	50 ST 50 J,K	'78→'93	20101-15	10106-41	420	88	40,01
1001500	50 XL 50	'82	20101-14	10106-42	420	98	40,64
1001107	50 Z 50 Monkey	'00	20104-13	10109-35	420	78	30,60
1001103	50 Z 50 Monkey	'00	20104-14	10109-35	420	88	32,03
1001100	50 ZB 50	'87	20101-15	10106-38	420	104	39,52
1005102	70 CT 70	'76→'80	20101-15	10106-35	420	86	36,58
1005102	70 ST 70 Dax	'82→'01	20101-15	10106-35	420	86	36,58
1005101	70 ST 70 Dax	'76→'81	20101-15	10106-38	420	88	37,49
1007100	80 CY 80	'79	20101-15	10106-35	420	92	37,35
1007200	80 MB 80	'80	20101-15	10103-42	420	108	37,80
1007600	80 MT 80	'80	20101-15	10103-40	420	106	36,83
1007601	80 MTX 80	'82	20101-15	10103-45	420	122	41,38
1007602	80 MTX 80 R D,F	'83→'84	20101-14	10103-42	420	122	38,96
1009100	90 EZ 90	'91→'95	26200-14	10201-35	428	100	34,58
1013107	125 MONKEY 125	'18→'20	20101-15	10117-34	420	98	33,36
1013108	125 SUPER CUB 125	'19→'20	20101-14	10122-36	420	106	29,69
1013100	125 ANF 125 Innova 3,4,5,6,7,8,9,A,B	'03→'11	20101-14	10117-35	420	104	33,50
1013103	125 ANF 125 Supra X	'11→'12	20101-14	10117-35	420	104	33,50
1013105	125 ANF 125 Wave	'11→'12	20101-14	10117-35	420	104	33,50
1013163	125 CA 125 Rebel S,T,V,W,X,Y	'95→'00	20317-13	10221-39	520	112	66,92
1013205	125 CB 125 R	'18→'19	20209-15	10237-47	428	134	46,88
1013204	125 CB 125 F GLR 125 F,G,H	'15→'17	20209-15	10236-45	428	122	38,40
1013139	125 CB 125 J/R	'83→'86	20200-15	10201-37	428	108	36,30
1013200	125 CB 125 JX	'75→'79	26200-15	10201-47	428	118	43,48
1013200	125 CB 125 K1-K5,K1-K5,K1-K5,K1-K5,K1-K5	'72→'76	26200-15	10201-47	428	118	43,48
1013133	125 CB 125 N	'79	20200-15	10201-37	428	100	35,25
1013131	125 CB 125 S	'75→'79	20200-15	10201-40	428	102	37,32
1013132	125 CB 125 S3,S3,S3,S3,S3,S3,S3,S3	'76→'83	20200-15	10201-35	428	100	34,48
1013201	125 CB 125 T	'77→'78	20200-15	10201-39	428	112	38,61
1013201	125 CB 125 T2	'78→'82	20200-15	10201-39	428	112	38,61
1013202	125 CB 125 TD C,D,E,F,G,H,J	'82→'88	20200-15	10201-40	428	120	39,66
1013203	125 CBF 125 M 9,A,B,C,D,E,F,G	'09→'16	20209-16	10235-42	428	118	36,51
1013304	125 CBR 125 R 4,5,6	'04→'06	20209-15	10229-42	428	124	37,14
1013241	125 CBR 125 R C,D,E,F,G	'12→'16	20209-15	10236-44	428	128	38,75
1013304	125 CBR 125 RW 5,6,7,8,9,A	'05→'10	20209-15	10229-42	428	124	37,14
1013241	125 CBR 125 RW B	'11	20209-15	10236-44	428	128	38,75
1013135	125 CG 125 BR F,G,H,J,K,L,M	'85→'91	20200-14	10223-41	428	110	35,04
1013136	125 CG 125 BR N,P,R,S,T,V	'92→'97	20200-14	10223-41	428	114	35,56
1013136	125 CG 125 Cargo 9,A	'09→'10	20200-14	10223-41	428	114	35,56
1013138	125 CG 125 ES 4,5,6,7,8	'04→'08	20200-14	10230-45	428	116	41,34
1013134	125 CG 125 K1,K1,K1,A,B,C,D,E	'77→'84	20200-14	10201-34	428	100	33,92
1013140	125 CG 125 Titan	'99	20200-14	10223-43	428	116	36,13
1013137	125 CG 125 W,X,Y,1,2,3	'98→'03	20200-15	10201-36	428	112	36,79
1013509	125 CLR 125 W City Fly X,X,Y,1,2,3	'98→'03	26200-17	10216-50	428	128	63,29
1013162	125 CM 125 C C,D,E,F	'82→'85	20200-15	10223-43	428	120	37,21
1013161	125 CM 125 T	'81→'82	20200-15	10223-39	428	114	35,95
1013603	125 CRM 125 R L,M,N,P,R	'90→'94	20305-14	10215-40	520	108	65,81
1013604	125 CRM 125 R S,T,V,W,X	'95g'99	20305-14	10215-38	520	108	63,22
1013101	125 CT 125 C F	'85	20200-15	10201-51	428	120	46,48
1013106	125 GROM 125 A AC ABS J	'18	20101-15	10117-34	420	106	34,38
1013106	125 GROM 125 AC D,E,F,G,H,J	'13→'18	20101-15	10117-34	420	106	34,38
1013106	125 MSX 125 A ABS H,J	'17→'18	20101-15	10117-34	420	106	34,38
1013106	125 MSX 125 D,E,F,G,H	'13→'17	20101-15	10117-34	420	106	34,38
1013602	125 MTX 125 R G,H,J,K,L,M,N,P,R,S	'86→'95	20203-13	10214-40	520	106	64,61
1013600	125 MTX 125 RW D,E,F,G	'83→'86	20200-15	10205-53	428	130	51,07



KIT AFAM / AFAM KIT

Codice Kit Code	Applicazione Application	Anno Year	Pignone F. Sprocket	Corona R. Sprocket	Passo Pitch	Mg. Nm	€
1013602	125 MTX 125 RW H,J,K,L,M,N,P,R,S	'87→'95	20203-13	10214-40	520	106	64,61
1013306	125 NSR 125 F J,K,L,M,N	'88→'92	20203-13	10215-36	520	108	61,47
1013301	125 NSR 125 R F,G,H,J	'85→'88	20203-13	10214-33	520	106	58,77
1013302	125 NSR 125 R K,L,M,N	'89→'92	20305-13	10215-35	520	108	61,92
1013303	125 NSR 125 R P,R,S,T,V,W,X	'93→'99	20305-14	10215-36	520	108	62,20
1013305	125 NSR 125 R Y,1	'00→'01	20305-14	10215-38	520	110	63,64
1013507	125 NX 125 Transcity K,L,M,N,P,R,S,T,V	'89→'97	20200-16	10216-50	428	128	62,94
1013500	125 SL 125 K1,K2,K2,K2,A	'76→'80	26200-15	10201-49	428	110	44,56
1013164	125 VT 125 C Shadow X,Y,1,2,3,4,5,6,7,8	'99→'08	20305-14	10221-41	520	112	67,80
1013501	125 XL 125 K2,K3	'78→'79	20200-15	10201-43	428	114	39,62
1013511	125 XL 125 Paris Dakar F,G,H,J,K,L, M,N,P,R,S,T,V	'85→'97	20200-16	10216-50	428	128	62,94
1013506	125 XL 125 R C,D,E,F,G,H,J,K,L,M, N,P,R,S,T,V	'82→'97	20200-15	10203-53	428	128	50,79
1013502	125 XL 125 S Z,A,B,C	'79→'82	20200-14	10223-47	428	118	42,53
1013551	125 XL 125 V Varadero Y,1,2,3,4,5,6, 7,8,9,A,B,C,D,E,F,G	'00→'16	20305-14	10221-44	520	110	71,13
1013508	125 XLR 125 R V,W,X,Y,1	'97→'01	26200-17	10226-51	428	132	48,86
1013510	125 XR 125 L 3,4,5,6,7,8	'03→'08	20209-17	10228-54	428	132	46,59
1015200	150 CBF 150	'11→'12	20209-15	10223-42	428	120	36,33
1015241	150 CBR 150	'06→'12	20209-15	10223-42	428	124	36,86
1015100	150 GTR 150 SUPRA 2019-2020	'19→'20	20209-15	10236-44	428	120	37,73
1021161	200 CD 200 T A,B	'80→'81	20200-15	10201-35	428	112	36,02
1021161	200 CM 200 T A,B,C,D,E	'80→'84	20200-15	10201-35	428	112	36,02
1021600	200 MTX 200 RW D,E,F,G	'83→'86	20202-13	10206-42	520	104	65,31
1026201	250 CB 250	'78→'78	20400-15	10402-41	530	102	112,70
1026200	250 CB 250 K3,K4,K5,G5	'73→'75	20400-16	10401-38	530	98	106,37
1026201	250 CB 250 N A	'79→'80	20400-15	10402-41	530	102	112,70
1026202	250 CB 250 Nighthawk N,P,R,S,T,V,W,X,Y	'92→'00	20317-14	10218-31	520	108	60,63
1026131	250 CB 250 RS A	'80→'80	20500-14	10310-44	520	98	68,85
1026132	250 CB 250 RS B,C,D	'81→'83	20500-14	12323-44	520	98	68,85
1026208	250 CB 250 T	'78→'78	20400-15	10402-41	530	102	112,70
1026203	250 CB 250 Two Fifty N,P,R,S,T,V,W,X, Y,1,2,3,4,5	'92→'05	20317-14	10218-31	520	104	59,75
1026204	250 CBF 250 4,5,6	'04→'06	20320-13	10301-37	520	106	62,48
1026241	250 CBR 250 R B,C,D	'11→'13	20320-14	10337-38	520	108	66,23
1026241	250 CBR 250 RA ABS B,C,D	'11→'13	20320-14	10337-38	520	108	66,23
1026207	250 CJ 250 T	'77	20400-16	10401-38	530	100	107,60
1026162	250 CM 250 C B,C,D,F	'82→'85	20317-14	10218-31	520	98	58,42
1026164	250 CM 250 C,D	'83→'84	20317-14	10214-40	520	94	63,25
1026166	250 CM 250 X	'99	20317-14	10221-39	520	108	66,33
1026165	250 CMX 250	'88	20317-14	10214-33	520	108	60,49
1026163	250 CMX 250 C Rebel T,V,W,X,Y	'96→'00	20317-14	10218-31	520	108	60,63
1026503	250 NX 250 2 L,P	'90→'93	20304-13	12323-41	520	102	63,92
1026503	250 NX 250 AX-1 K,L,M,N,P,R	'89→'94	20304-13	12323-41	520	102	63,92
1026503	250 NX 250 H,J,K,L,M,N,P	'87→'93	20304-13	12323-41	520	102	63,92
1026501	250 XL 250 R C,D	'82→'83	20500-14	12323-44	520	100	69,31
1026502	250 XL 250 R E,F,G,H	'84→'87	20202-13	10311-38	520	102	61,15
1026500	250 XL 250 S Z,A,B	'78→'81	20500-14	12323-53	520	102	79,81
1030131	300 CB 300 R NAJ	'18→'20	20320-14	10338-36	520	108	103,22
1030200	300 CB 300 FA ABS F,G	'15→'16	20320-14	10337-36	520	108	103,22
1030241	300 CBR 300 RA ABS E,F,G,H	'14→'17	20320-14	10337-36	520	108	103,22
1035201	350 CB 350 F Four	'72→'75	20400-17	10401-38	530	96	105,63
1035200	350 CB 350 K4	'74	20400-16	10401-38	530	98	106,37
1035500	350 XL 350 R E,F,G,H	'84→'87	20306-14	10316-38	520	102	102,63
1036200	360 CB 360 G5	'75→'75	20400-16	10401-36	530	96	103,74
1043200	400 CB 400 F	'75→'79	20400-17	10401-38	530	96	105,63



KIT AFAM / AFAM KIT

Codice Kit Code	Applicazione Application	Anno Year	Pignone F. Sprocket	Corona R. Sprocket	Passo Pitch	Mg. Nm	€
1043205	400 CB 400 N B,C,D	'81→'83	20401-16	10406-36	520	100	107,03
1043202	400 CB 400 N Z,A	'78→'80	20400-16	10402-36	530	100	106,23
1043202	400 CB 400 T	'78	20400-16	10402-36	530	100	106,23
1043203	400 CBX 400 F,F2	'82→'83	20400-15	10405-45	530	104	118,80
1043161	400 CM 400 T A	'79→'80	20400-16	10402-35	530	102	107,45
1043162	400 CM 400 T B,C,D	'81→'83	20401-16	10406-36	520	102	108,26
1043300	400 NS 400 R F,G,H,J,K	'85→'89	20402-16	10404-40	530	108	121,45
1043204	400 VF 400 F D,E,F	'83→'85	20403-15	10405-46	530	108	125,34
1043242	400 VFR 400 R F,G	'85→'86	20402-16	10404-40	530	108	121,45
1043241	400 VFR 400 R K,L,M,N	'89→'92	20405-15	10602-40	525	104	126,53
1043502	400 XL 400 R C	'82	20500-15	12323-47	520	104	115,89
1043500	400 XL 400 S	'81	20500-14	12323-44	520	100	108,89
1051202	450 CB 450 DX K,L,M,N	'89→'92	20404-16	10504-36	525	108	126,08
1051201	450 CB 450 S G,H,J	'86→'88	20404-16	10504-36	525	108	126,08
1051200	450 CB 450 T	'82	20400-15	10503-35	530	92	100,42
1051161	450 CMX 450 C Rebel H,J	'87→'88	20404-16	10504-36	525	112	128,95
1059201	500 CB 500 F	'77	20502-17	10505-34	530	98	107,77
1059207	500 CB 500 F D,E,F,G	'13→'16	20407-15	10627-41	520	112	120,76
1059208	500 CB 500 FA ABS D,E,F,G,H,J	'13→'18	20407-15	10627-41	520	112	120,76
1059201	500 CB 500 K1,K2	'75→'76	20502-17	10505-34	530	98	107,77
1059203	500 CB 500 R,S,T,V,W,X,Y,1,2,3	'94→'03	20405-15	10608-40	525	108	129,37
1059211	500 CB 500 S W,X,Y,1,2,3	'98→'03	20405-15	10608-40	525	108	129,37
1059200	500 CB 500 T	'75→'77	20400-15	10503-33	530	100	102,45
1059209	500 CB 500 X D,E,F	'13→'15	20407-15	10627-41	520	112	120,76
1059209	500 CB 500 XA ABS D,F,G,G,H,J	'13→'18	20407-15	10627-41	520	112	120,76
1059204	500 CBF 500 4,5,6,7	'04→'07	20405-15	10517-41	525	116	136,40
1059205	500 CBF 500 A ABS 4,5,6,7	'04→'07	20405-15	10517-41	525	116	136,40
1059210	500 CBR 500 R D,E,F	'13→'15	20407-15	10627-41	520	112	120,76
1059210	500 CBR 500 RA D,E,F,G,H,J	'13→'18	20407-15	10627-41	520	112	120,76
1059161	500 CMX 500 A H,J	'17→'18	20407-15	10521-40	520	112	122,68
1059131	500 FT 500 C,D,E	'82→'84	20503-15	10405-40	530	100	112,53
1059504	500 NX 500 Dominator J	'88→'88	20508-15	10501-45	520	108	117,08
1059505	500 NX 500 Dominator K,L,M,N,P,R,S, T,V,W,X	'89→'99	20509-15	10501-45	520	108	117,08
1059202	500 VF 500 F D,E	'83→'84	20403-15	10405-43	530	108	123,52
1059206	500 VF 500 F2 F,G,H	'85→'87	20403-15	10405-40	530	108	118,79
1059132	500 XBR 500 F,G,H	'85→'87	20513-15	10504-36	525	108	128,60
1059133	500 XBR 500 S G,H,J	'86→'88	20513-15	10504-36	525	108	128,60
1059502	500 XL 500 R C	'82	20500-15	12323-41	520	100	105,56
1059503	500 XL 500 R D,E,F,G,H	'83→'87	20500-15	12323-41	520	102	104,28
1059500	500 XL 500 S Z,A,B	'79→'81	20500-14	12323-39	520	96	101,54
1059212	500 CB 500 XA	'19→'20	20407-15	10521-41	520	112	124,34
1068200	550 CB 550 F/K	'77→'80	20502-17	10505-37	530	100	113,27
1068202	550 CBX 550 F C	'82	20402-16	10405-45	530	104	125,52
1068201	550 CBX 550 F D	'83	20402-16	10405-43	530	104	123,70
1070206	600 CB 600 F Hornet 7,8,9,A,B,C,D	'07→'13	20612-16	10613-43	525	118	143,12
1070203	600 CB 600 F Hornet W,X,Y,1,2,3,4,5,6	'98→'06	20515-15	10613-42	525	110	131,71
1070211	600 CB 600 FA Hornet ABS 7,8,9,A,B,C,D	'07→'13	20612-16	10613-43	525	118	143,12
1070203	600 CB 600 FA Hornet ABS Y,1,2,3,4	'00→'04	20515-15	10613-42	525	110	131,71
1070208	600 CBF 600 N 4,5,6,7	'04→'07	20515-15	10613-43	525	116	140,11
1070210	600 CBF 600 N 8,9,A,B,C	'08→'12	20612-16	10613-42	525	124	143,33
1070208	600 CBF 600 NA ABS 4,5,6,7	'04→'07	20515-15	10613-43	525	116	140,11
1070209	600 CBF 600 NA ABS 8,9,A,B,C	'08→'12	20612-16	10613-42	525	124	143,33
1070204	600 CBF 600 S 4,5,6,7	'04→'07	20515-15	10613-43	525	116	140,11
1070212	600 CBF 600 S 8,9,A,B,C,D	'08→'13	20612-16	10613-42	525	124	143,33
1070205	600 CBF 600 SA ABS 4,5,6,7	'04→'07	20515-15	10613-43	525	116	140,11
1070207	600 CBF 600 SA ABS 8,9,A,B,C,D	'08→'13	20612-16	10613-42	525	124	143,33
1070242	600 CBR 600 F 1,2,3,4,5,6,7	'01→'07	20612-16	10617-45	525	108	140,36
1070213	600 CBR 600 F B,C,D	'11→'13	20612-16	10613-43	525	120	144,55



KIT AFAM / AFAM KIT

Codice Kit Code	Applicazione Application	Anno Year	Pignone F. Sprocket	Corona R. Sprocket	Passo Pitch	Mg. Nm	€
1070200	600 CBR 600 F H,J,K,L	'87→'90	20504-15	10405-43	530	110	140,36
1070201	600 CBR 600 F M,N,P,R,S,T	'91→'96	20504-15	10508-43	530	108	138,92
1070202	600 CBR 600 F V,W	'97→'98	20515-15	10613-43	525	108	134,37
1070241	600 CBR 600 F X,Y	'99→'00	20612-16	10613-44	525	108	135,98
1070245	600 CBR 600 F4 X,Y	'99→'00	20612-16	10613-45	525	108	137,31
1070213	600 CBR 600 FA ABS B,C,D	'11→'13	20612-16	10613-43	525	120	144,55
1070243	600 CBR 600 FS 1,2	'01→'02	20612-16	10617-46	525	108	140,36
1070248	600 CBR 600 RA C-ABS 9,A,B,C,D,E	'09→'14	20612-16	10617-41	525	112	137,80
1070247	600 CBR 600 RA C-ABS F,G	'15→'16	20612-16	10617-41	525	112	137,80
1070244	600 CBR 600 RR 3,4,5,6	'03→'06	20612-16	10617-42	525	112	137,80
1070247	600 CBR 600 RR 7,8,9,A,B,C,D,E,F,G	'07→'16	20612-16	10617-41	525	112	137,80
1070161	600 VT 600 C Shadow Custom G	'86	20506-16	10504-44	525	120	143,85
1070162	600 VT 600 C Shadow Custom H,J,K,L, M,N,P,R,S,T,V,W,X,Y	'87→'00	20507-16	10504-44	525	120	143,85
1070551	600 XL 600 LM F,G,H	'85→'87	20500-15	12323-40	520	106	108,12
1070500	600 XL 600 R D,E,F,G,H	'83→'87	20500-15	12323-41	520	104	108,01
1070551	600 XL 600 RM G	'86	20500-15	12323-40	520	106	108,12
1070553	600 XL 600 V Transalp H,J	'87→'88	20506-15	10502-47	525	118	142,53
1070554	600 XL 600 V Transalp K,L,M,N,P,R,S, T,V,W,X,Y	'89→'00	20507-15	10502-47	525	118	142,53
1070502	600 XL 600 RM	'86	20500-15	12323-40	520	106	108,12
1073162	650 CB 650 C Custom A,B	'80→'81	20505-16	10603-39	530	104	115,61
1073201	650 CB 650 F E	'14	20612-15	10613-42	525	118	137,42
1073202	650 CB 650 F F,G	'15→'16	20612-15	10613-42	525	118	137,42
1073202	650 CB 650 FA ABS E,F,G,H,J	'14→'18	20612-15	10613-42	525	118	137,42
1073200	650 CB 650 Z,A,B	'79→'81	20505-16	10603-40	530	102	114,45
1073131	650 CB 650 R 2019-2020	'19→'20	20612-15	10613-42	525	118	137,42
1073241	650 CBR 650 F E,F,G	'14→'16	20612-15	10613-42	525	118	137,42
1073241	650 CBR 650 FA ABS E,F,G,H	'14→'17	20612-15	10613-42	525	118	137,42
1073242	650 CBR 650 R	'19→'20	20612-15	10613-42	525	118	137,42
1073636	650 FMX 650 5,6,7,8	'05→'08	20509-14	10501-42	520	110	112,57
1073505	650 FX 650 Vigor X,Y,1,2,3	'99→'03	20509-14	10501-43	520	108	115,12
1073100	650 NT 650 GT Hawk J,K,L,M	'88→'91	20507-16	10409-44	525	112	135,11
1073500	650 NX 650 Dominator J	'88→'88	20508-15	10501-45	520	108	117,08
1073501	650 NX 650 Dominator K,L	'89→'90	20509-15	10501-45	520	108	117,08
1073502	650 NX 650 Dominator M,N,P,R,S	'91→'95	20509-15	10501-47	520	110	121,07
1073503	650 NX 650 Dominator T,V,W,X,Y,1,2	'96→'02	20509-15	10501-46	520	110	118,31
1073504	650 SLR 650 V,W	'97→'98	20509-14	10501-43	520	108	115,12
1073552	650 XL 650 V Transalp Y,1,2,3,4,5,6,7	'00→'07	20507-15	10502-48	525	118	142,53
1073551	650 XRV 650 Africa Twin J,K	'88→'89	20507-16	10502-49	525	124	149,66
1075101	700 CTX 700 D E	'14	20617-16	10627-39	520	112	120,86
1075101	700 CTX 700 E	'14	20617-16	10627-39	520	112	120,86
1075101	700 CTX 700 N E	'14	20617-16	10627-39	520	112	120,86
1075101	700 CTX 700 ND E,F,G	'14→'16	20617-16	10627-39	520	112	120,86
1075100	700 NC 700 D Integra ABS C,D	'12→'13	20617-16	10627-39	520	112	120,86
1075133	700 NC 700 S ABS C,D	'12→'13	20617-16	10627-39	520	112	120,86
1075131	700 NC 700 S C,D	'12→'13	20617-16	10627-43	520	114	126,98
1075132	700 NC 700 SA ABS C,D	'12→'13	20617-16	10627-43	520	114	126,98
1075202	700 NC 700 X C,D	'12→'13	20617-16	10627-43	520	114	126,98
1075203	700 NC 700 X E	'14	20617-16	10627-43	520	114	126,98
1075203	700 NC 700 XA ABS C,D	'12→'13	20617-16	10627-43	520	114	126,98
1075204	700 NC 700 XD C,D,E	'12→'14	20617-16	10627-39	520	112	120,86
1075200	700 VF 700 S	'84→'85	20602-16	10605-44	530	110	139,83
1075201	700 VFR 700 F Interceptor	'86→'87	20602-16	10605-45	530	110	141,65
1075551	700 XL 700 V Transalp 8,9,A,B,C,D	'08→'13	20507-15	10502-47	525	118	142,53
1075552	700 XL 700 VA Transalp ABS 8,9,A,B,C,D	'08→'13	20507-15	10502-47	525	118	142,53
1077555	750 ADV 750 X	'17→'20	20617-17	10627-38	520	118	126,18
1077161	750 CB 750 C Custom A	'80	20602-18	10603-43	530	106	139,20
1077169	750 CB 750 C Custom B	'81	20602-18	10603-39	530	106	134,48
1077199	750 CB 750 F	'76	20502-17	10603-48	530	102	139,02



KIT AFAM / AFAM KIT

Codice Kit Code	Applicazione Application	Anno Year	Pignone F. Sprocket	Corona R. Sprocket	Passo Pitch	Mg. Nm	€
1077204	750 CB 750 F Z,A,B,C,D,E	'79	20602-18	10605-46	530	108	142,45
1077199	750 CB 750 F1	'77	20502-17	10603-48	530	102	139,02
1077201	750 CB 750 F2	'78	20600-15	10604-41	630	88	203,36
1077210	750 CB 750 F2 Seven Fifty N,P,R	'92→'94	20607-15	10608-40	525	112	129,93
1077211	750 CB 750 F2 Seven Fifty S,T,V,W,X, Y,1,2,3	'95→'03	20611-15	10608-40	525	112	129,93
1077200	750 CB 750 K 0,0,1,1,2,3,4,5,6	'69→'77	20502-18	10603-48	530	102	140,00
1077201	750 CB 750 K 7	'78	20600-15	10604-41	630	88	203,36
1077203	750 CB 750 K A,B	'80→'81	20602-18	10603-46	530	108	142,45
1077212	750 CB 750 Nighthawk M,N,P,R,S,T,V, W,X,Y,1,2,3	'91→'03	20611-15	10608-40	525	112	142,49
1077205	750 CBX 750 F E,F,G,H	'84→'87	20602-16	10605-45	530	114	144,55
1077100	750 NC 750 D Integra E,F,G,H,J	'14→'18	20617-17	10627-39	520	112	122,09
1077101	750 NC 750 D Integra S E,F,G,H,J	'14→'18	20617-17	10627-39	520	112	122,09
1077102	750 NC 750 J NM 4 Vultus F,G	'15→'16	20617-17	10627-39	520	112	122,09
1077131	750 NC 750 S E,F,G	'14→'16	20617-17	10627-43	520	114	128,21
1077131	750 NC 750 SA ABS E,F,G,H	'14→'17	20617-17	10627-43	520	114	128,21
1077553	750 NC 750 X E,F	'14→'15	20617-17	10627-43	520	114	128,21
1077553	750 NC 750 XA ABS E,F,G,H,J	'14→'18	20617-17	10627-43	520	114	128,21
1077554	750 NC 750 XD E,F,G,H,J	'14→'18	20617-17	10627-39	520	112	122,09
1077372	750 RVF 750 R R,S,T,V,W	'94→'98	20609-17	10602-40	525	108	129,44
1077167	750 VF 750 C 1,2,3,4	'01→'04	20603-16	10605-40	530	118	143,01
1077162	750 VF 750 C P,R,S	'93→'95	20603-16	10605-40	530	120	144,45
1077164	750 VF 750 C T,V,W,X,Y	'96→'00	20603-16	10605-39	530	118	143,01
1077206	750 VF 750 F Interceptor D,E,F	'83→'85	20602-17	10605-44	530	110	140,81
1077207	750 VFR 750 F G,H	'86→'87	20602-16	10605-45	530	110	141,65
1077208	750 VFR 750 F J,K	'88→'89	20603-16	10605-45	530	110	143,79
1077209	750 VFR 750 F L,M,N,P,R,S,T,V	'90→'97	20603-16	10607-43	530	112	143,40
1077371	750 VFR 750 R J,K,L	'88→'90	20605-16	10602-40	525	106	128,04
1077163	750 VT 750 C Shadow Aero 9	'09→'09	20614-17	10613-41	525	122	140,29
1077163	750 VT 750 C Shadow V,W,X,Y,1,2,3, 4,5,6,7,8	'97→'08	20614-17	10613-41	525	122	140,29
1077163	750 VT 750 C2 Shadow V,W,X,Y,1	'97→'01	20614-17	10613-41	525	122	140,29
1077166	750 VT 750 DC Black Widow 1,2,3,4	'01g'04	20614-17	10613-42	525	124	141,72
1077165	750 VT 750 DC Black Widow Y	'00	20614-17	10613-41	525	124	141,72
1077168	750 VT 750 DC Shadow Spirit 7,8,9	'07→'09	20614-17	10613-42	525	122	140,29
1077170	750 VT 750 S B	'11	20614-17	10613-38	525	112	129,19
1077170	750 VT 750 S VT750RS A	'10	20614-17	10613-38	525	112	129,19
1077551	750 XRV 750 Africa Twin L,M,N	'90→'92	20606-16	10608-46	525	124	146,09
1077552	750 XRV 750 Africa Twin P,R,S,T,V,W, X,Y,1,2,3	'93→'03	20606-16	10608-45	525	124	146,09
1080201	800 VFR 800 2,3,4,5	'02→'05	20602-16	10619-43	530	110	142,95
1080202	800 VFR 800 A ABS 2,3,4,5	'02→'05	20602-16	10619-43	530	110	142,95
1080202	800 VFR 800 A VTEC ABS 6,7,8,9,9, 9,9,9	'06→'13	20602-16	10619-43	530	110	142,95
1080204	800 VFR 800 FA ABS E,F,G,H,J	'14→'18	20618-16	10628-43	525	110	160,62
1080200	800 VFR 800 Fi W,X,Y,1,2,3,4,5	'98→'05	20602-17	10607-43	530	108	139,37
1080201	800 VFR 800 VTEC 6,7,8,9	'06→'09	20602-16	10619-43	530	110	142,95
1080205	800 VFR 800 X Crossrunner F	'15	20618-16	10628-43	525	110	160,62
1080203	800 VFR 800 XA Crossrunner ABS B,C, D,E,F,G,H,J	'11→'18	20602-16	10619-43	530	110	142,95
1086200	900 CB 900 F Bol d'Or Z,A,B	'79→'81	20602-17	10605-44	530	106	137,94
1086200	900 CB 900 F C,D	'82→'83	20602-17	10605-44	530	106	137,94
1086201	900 CB 900 F Hornet 2,3,4,5,6,7	'02→'07	20603-16	10508-43	530	114	144,87
1086242	900 CBR 900 Evolution Blade X	'99	20612-16	10613-42	525	108	156,77
1086241	900 CBR 900 RR Fireblade N,P,R,R,S,S	'92→'95	20603-16	10508-42	530	108	168,98
1086242	900 CBR 900 RR Fireblade T,T,V,V,W,X	'96→'99	20612-16	10613-42	525	108	156,77
1086243	900 CBR 929 RR Fireblade Y,1	'00→'01	20603-16	10616-42	530	108	172,10
1086243	900 CBR 954 RR Fireblade 2,3	'02→'03	20603-16	10616-42	530	108	172,10
1089207	1000 CB 1000 F Big One P,R,S,T,V	'93→'97	20602-17	10605-42	530	116	175,95
1089132	1000 CB 1000 R 9,A,B,C,D,E,F	'09→'15	20603-16	10801-44	530	116	183,33



KIT AFAM / AFAM KIT

Codice Kit Code	Applicazione Application	Anno Year	Pignone F. Sprocket	Corona R. Sprocket	Passo Pitch	Mg. Nm	€
1089133	1000 CB 1000 RA ABS 9,A,B,C,D,E,F,G	'09→'16	20603-16	10801-44	530	116	183,33
1092213	1100 CB 1100 RS	'17→'19	20602-18	10508-40	530	110	172,62
1089134	1000 CB 1000 RA	'18→'20	20611-15	10628-44	525	116	196,60
1089209	1000 CBF 1000 6,7,8,9,A,B,C	'06→'12	20603-16	10508-43	530	120	184,28
1089210	1000 CBF 1000 A ABS 6,7,8,9,A	'06→'10	20603-16	10508-43	530	120	184,28
1089213	1000 CBF 1000 F A,B,C,D,E,F	'10→'15	20603-16	10508-41	530	120	181,16
1089212	1000 CBF 1000 FA ABS A,B,C,D,E,F,G	'10→'16	20603-16	10508-41	530	120	181,16
1089212	1000 CBF 1000 FS ABS A,B,C,D	'10→'13	20603-16	10508-41	530	120	181,16
1089212	1000 CBF 1000 FT ABS A,B,C,D	'10→'13	20603-16	10508-41	530	120	181,16
1089210	1000 CBF 1000 S ABS 7,8,9,A,B	'07→'11	20603-16	10508-43	530	120	184,28
1089210	1000 CBF 1000 T ABS 7,8,9,A,B	'07→'11	20603-16	10508-43	530	120	184,28
1089212	1000 CBF 1000 T ABS C,D,E,F	'12→'15	20603-16	10508-41	530	120	181,16
1089205	1000 CBR 1000 F H,J	'87→'88	20602-17	10605-43	530	114	177,03
1089206	1000 CBR 1000 F K,L,M,N,P,R,R,S,S	'89→'95	20602-17	10605-42	530	114	173,92
1089208	1000 CBR 1000 F T,T,V,V,W,W,X,X	'96→'99	20602-17	10605-41	530	114	173,92
1089246	1000 CBR 1000 RA Fireblade -ABS + RR	'17→'18	20612-16	10617-43	525	120	208,05
1089244	1000 CBR 1000 RA Fireblade C-ABS 9, A,B,C,D,E,F,G	'09→'16	20603-16	10616-42	530	116	180,22
1089241	1000 CBR 1000 RR Fireblade 4,5	'04→'05	20603-16	10616-40	530	114	176,58
1089242	1000 CBR 1000 RR Fireblade 6,7	'06→'07	20603-16	10616-42	530	114	178,19
1089243	1000 CBR 1000 RR Fireblade 8,9,A,B, C,D,E,F,G	'08→'16	20603-16	10616-42	530	116	230,38
1089245	1000 CBR 1000 RR SP S Fireblade+ TT EDITION	'14→'16	20603-16	10616-42	530	116	230,38
1089246	1000 CBR 1000 RR SP SA Fireblade ABS + SP2	'17→'18	20612-16	10617-43	525	120	208,05
1089247	1000 CBR 1000 RR/RR-R SP	'20	20612-16	10617-40	525	118	200,22
1089201	1000 CBX 1000 B,C	'81→'82	20801-18	10605-42	530	108	154,43
1089553	1000 CRF 1000 L Africa Twin ABS + Adventure sport ABS J	'16→'18	20612-16	10802-42	525	124	205,81
1089203	1000 VF 1000 F E	'84	20602-17	10605-43	530	110	158,66
1089204	1000 VF 1000 F F,G	'85→'86	20602-17	10605-43	530	114	162,19
1089202	1000 VF 1000 R E,F,G	'84→'86	20602-17	10605-43	530	110	172,97
1089131	1000 VTR 1000 F Firestorm V,W,X,Y,1, 2,3,4,5,6	'97→'06	20603-16	10508-41	530	102	162,89
1089371	1000 VTR 1000 SP SP1 Y,1	'00→'01	20603-16	10616-40	530	104	166,43
1089372	1000 VTR 1000 SP SP2 2,3,4,5,6	'02→'06	20603-16	10616-40	530	106	168,46
1089551	1000 XL 1000 V Varadero X,Y,1,2,3,4, 5,6,7,8,9,A,B	'99→'11	20612-16	10613-47	525	112	169,02
1089552	1000 XL 1000 VA Varadero ABS 4,5,6, 7,8,9,A,B,C	'04→'12	20612-16	10613-47	525	112	169,02
1092551	1100 CRF 1100 AFRICA TWIN	'20	20612-16	10802-42	525	124	198,47
1092210	1100 CB 1100 A ABS D	'13	20602-18	10508-39	530	110	217,08
1092211	1100 CB 1100 A ABS E,F	'14→'15	20802-18	10508-40	530	110	220,19
1092212	1100 CB 1100 EX ABS H,J	'17→'18	20802-18	10508-40	530	110	220,19
1092212	1100 CB 1100 EX E,F,G	'14→'16	20802-18	10508-40	530	110	220,19
1092203	1100 CB 1100 F D	'83	20602-17	10605-41	530	104	150,23
1092200	1100 CB 1100 R A,B	'80→'81	20602-17	10605-40	530	104	148,62
1092201	1100 CB 1100 R C	'82	20602-17	10605-39	530	104	148,62
1092209	1100 CB 1100 R D,E,F	'83→'85	20602-17	10605-41	530	104	150,23
1092212	1100 CB 1100 RS ABS H	'17	20802-18	10508-40	530	110	220,19
1092212	1100 CB 1100 SA ABS E	'14	20802-18	10508-40	530	110	220,19
1092205	1100 CB 1100 SF X11 Y,1,2,3	'00→'03	20602-17	10508-43	530	110	172,97
1092204	1100 CBR 1100 XX Blackbird V,W,X,Y,1, 2,3,4,5,6,7,8	'97→'08	20602-17	10508-44	530	110	220,54
1097206	1300 CB 1300 DC X4 V,W,X,Y	'97→'00	20602-18	10508-41	530	122	236,05
1097200	1300 CB 1300 F Superfour 3,4,5,6,7,8,9	'03→'09	20602-18	10508-39	530	114	222,85
1097205	1300 CB 1300 F W,X,Y,1	'98→'01	20602-18	10508-41	530	116	227,37
1097203	1300 CB 1300 N 5,6,7,8,9	'05→'09	20602-18	10508-39	530	114	222,85
1097204	1300 CB 1300 NA ABS 5,6,7,8,9	'05→'09	20602-18	10508-39	530	114	222,85
1097202	1300 CB 1300 S 5,6,7,8,9	'05→'09	20602-18	10508-39	530	114	222,85



KIT AFAM / AFAM KIT

Codice Kit Code	Applicazione Application	Anno Year	Pignone F. Sprocket	Corona R. Sprocket	Passo Pitch	Mg. Nm	€
1097201	1300 CB 1300 SA ABS 5,6,7,8,9,A, B,C,D	'05→'13	20602-18	10508-39	530	114	222,85

HONDA CORONE ALLUMINIO + TRASFORMAZIONE # 520

1113371	125 RS 125 1993-2005 RACING	'93→'05	20207-16	11207-38	415	120	56,74
1170403	600 CB 600 F Hornet W,X,Y,1,2,3,4,5,6	'98→'06	20516-15	11509-42	520	110	180,64
1170405	600 CBR 600 F 1,2,3,4,5,6,7	'01→'07	20613-16	11618-45	520	108	182,39
1170401	600 CBR 600 F M,N,P,R,S,T	'91→'96	20511-15	11509-43	520	108	179,62
1170402	600 CBR 600 F V,W	'97→'98	20516-15	11509-43	520	108	179,62
1170404	600 CBR 600 F X,Y	'99→'00	20613-16	11509-44	520	108	180,95
1170408	600 CBR 600 F4 X,Y	'99→'00	20613-16	11509-45	520	108	181,93
1170406	600 CBR 600 FS 1,2	'01→'02	20613-16	11618-46	520	108	182,39
1170410	600 CBR 600 RA C-ABS F,G	'15→'16	20613-16	11618-41	520	112	178,50
1170407	600 CBR 600 RR 3,4,5,6	'03→'06	20613-16	11618-42	520	112	181,30
1170410	600 CBR 600 RR 7,8,9,A,B,C,D,E,F,G	'07→'16	20613-16	11618-41	520	112	178,50
1173401	650 CBR 650 F E,F,G	'14→'16	20613-15	11509-42	520	118	187,53
1173401	650 CBR 650 FA ABS E,F,G,H	'14→'17	20613-15	11509-42	520	118	187,53
1173402	650 CBR 650 R RACING	'19→'20	20613-15	11509-42	520	118	187,53
1186403	900 CB 900 F Hornet 2,3,4,5,6,7	'02→'07	20608-16	11509-43	520	114	217,81
1186401	900 CBR 900 Evolution Blade X	'99	20613-16	11509-42	520	108	209,97
1186401	900 CBR 900 RR Fireblade T,T,V,V,W,X	'96→'99	20613-16	11509-42	520	108	209,97
1186402	900 CBR 929 RR Fireblade Y,1	'00→'01	20608-16	11618-42	520	108	207,52
1186402	900 CBR 954 RR Fireblade 2,3	'02→'03	20608-16	11618-42	520	108	207,52
1189416	1000 CBR 1000 RA Fireblade C-ABS H,J	'17→'18	20613-16	11618-43	520	120	224,39
1189407	1000 CBR 1000 RR Fireblade 4,5	'04→'05	20608-16	11618-40	520	114	208,92
1189409	1000 CBR 1000 RR Fireblade 6,7	'06→'07	20608-16	11618-42	520	114	214,59
1189413	1000 CBR 1000 RR Fireblade 8,9,A,B, C,D,E,F,G	'08→'16	20608-16	11618-42	520	116	216,93
1189414	1000 CBR 1000 RR SP S Fireblade + SA ABS	'14→'16	20608-16	11618-42	520	116	216,93
1189416	1000 CBR 1000 RR SP SA Fireblade ABS+ TT EDITION	'17→'18	20613-16	11618-43	520	120	224,39
1189401	1000 VTR 1000 F Firestorm V,W,X,Y, 1,2,3,4,5,6	'97→'06	20608-16	11509-41	520	102	199,61
1189402	1000 VTR 1000 SP SP1 Y,1	'00→'01	20608-16	11618-40	520	104	197,19
1189405	1000 VTR 1000 SP SP2 2,3,4,5,6	'02→'06	20608-16	11618-40	520	106	199,54

HRD

9301755	50 50 SM	'03→'11	94118-12	60104-56	428	134	79,31
9301753	50 50 Sonic 2 Enduro	'98→'02	94118-13	60104-56	428	134	80,08
9301753	50 50 Sonic 2 Supermotard	'98→'01	94118-13	60104-56	428	134	80,08

HUSQVARNA

6213638	125 SMS 4 125	'11→'14	21208-14	14205-54	428	136	50,79
6273551	650 TR 650 Strada	'12→'13	61301-16	35304-47	520	112	126,29
6273501	650 TR 650 Terra	'12→'13	61301-16	35304-47	520	112	126,29
6275636	690 701 Supermoto	'16	73303-16	71304-42	520	114	114,56
6275636	693 701 Supermoto	'17→'18	73303-16	71304-42	520	114	114,56
6286551	900 900 Nuda ABS	'12→'13	166600-17	62800-42	525	110	164,82
6286552	900 R 900 Nuda ABS	'12→'13	166600-16	62800-42	525	110	163,38

HYOSUNG

6513132	125 GA 125 Cruise	'95→'96	22200-14	14201-48	428	126	43,54
6513134	125 GA 125 Cruise	'97→'98	22205-14	14201-47	428	126	45,22
6513161	125 GA 125 F Cruise II	'99→'06	22205-14	14201-47	428	126	45,22



KIT AFAM / AFAM KIT

Codice Kit Code	Applicazione Application	Anno Year	Pignone F. Sprocket	Corona R. Sprocket	Passo Pitch	Mg. Nm	€
6513131	125 GF 125	'00→'05	22205-14	14201-47	428	126	45,22
6513133	125 GT 125 Comet	'03→'10	22205-14	65200-52	428	136	49,67
6513135	125 GT 125 i Naked	'13→'15	22205-14	65200-52	428	136	49,67
6513135	125 GT 125 Naked	'03→'12	22205-14	65200-52	428	136	49,67
6513200	125 GT 125 R	'06→'15	22205-14	65200-52	428	136	49,67
6513162	125 GV 125 Aguila	'01→'10	22205-13	14201-48	428	138	46,66
6513163	125 GV 125 C	'07→'15	22205-13	14201-48	428	138	46,66
6513100	125 RT 125 Karion	'02→'15	22205-13	14201-48	428	130	45,61
6513500	125 XRX 125 D Enduro	'99→'06	22205-14	14201-48	428	134	46,27
6526131	250 GT 250 Comet	'04→'10	21300-14	65301-46	520	112	73,89
6526200	250 GT 250 iR	'08→'15	21300-14	65301-46	520	112	73,89
6526131	250 GT 250 Naked	'11→'12	21300-14	65301-46	520	112	73,89
6526131	250 GT 250 Pi Naked	'13→'15	21300-14	65301-46	520	112	73,89
6526200	250 GT 250 R	'04→'07	21300-14	65301-46	520	112	73,89
6526201	250 GT 250 R Sport	'04→'08	21300-14	65301-46	520	112	73,89
6526161	250 GV 250 Aguila	'04→'07	21300-14	65300-46	520	116	74,77
6526161	250 GV 250 C	'08→'15	21300-14	65300-46	520	116	74,77
6573131	650 GT 650 Comet Naked	'04→'08	28401-15	65500-44	525	108	125,87
6573132	650 GT 650 i Naked	'12→'15	28401-15	65500-44	525	108	125,87
6573200	650 GT 650 iR	'09→'15	28401-15	65500-44	525	108	125,87
6573132	650 GT 650 Naked	'09→'11	28401-15	65500-44	525	108	125,87
6573200	650 GT 650 R	'06→'08	28401-15	65500-44	525	108	125,87
6573200	650 GT 650 S	'05→'08	28401-15	65500-44	525	108	125,87
6573200	650 GT 650 X	'07→'07	28401-15	65500-44	525	108	125,87
KAWASAKI							
1607600	80 AE 80 A1,A2,A3,A4,A5,A6,A7,A8,B1	'81→'89	24101-15	14100-43	420	116	38,86
1607200	80 AR 80 A1,C1,C2,C3,C4,C5,C6,C7,C8	'81→'89	24101-15	14100-43	420	114	38,61
1613161	125 BN 125 Eliminator A1,A2,A3,A4,A5,A6	'98→'03	24200-15	16201-46	428	132	45,26
1613162	125 BN 125 Eliminator A7,A8,A6F,A7F	'04→'07	24200-15	16201-42	428	130	42,08
1613636	125 D TRACKER	'10→'14	24203-14	16209-44	428	122	48,12
1613602	125 KDX 125 A1,A2,A3	'88→'90	24200-15	16207-52	428	130	48,17
1613600	125 KE 125 A4,A5,A6,A7,A8,A9, A10,A11,A12	'76→'84	33201-15	16202-50	428	118	44,91
1613300	125 KH 125 A1,A2,A3,A4,A5,A6	'77→'82	33200-14	14201-47	428	112	42,39
1613241	125 NINJA 125	'19→'20	21202-16	16212-56	428	132	45,00
1626131	250 BJ 250 Estrella B1,B2,B3,B4,B5, B6,B7,B7A	'92→'99	24501-15	16600-38	520	102	63,39
1626131	250 BJ 250 Estrella Custom D1,D2,D3, D4,D5,D6,D7	'96→'02	24501-15	16600-38	520	102	63,39
1626131	250 BJ 250 Estrella RS C1,C2,C3,C4	'99→'02	24501-15	16600-38	520	102	63,39
1626131	250 BJ 250 Estrella RS Custom E1,E2, E3,E4A	'96→'99	24501-15	16600-38	520	102	63,39
1626131	250 BJ 250 F1,F2	'02→'03	24501-15	16600-38	520	102	63,39
1626161	250 EL 250 D1,D2,D3,D4,D5	'90→'94	24502-14	16500-44	520	114	75,99
1626162	250 EL 250 F2,F3,F4	'96→'99	24502-14	16500-40	520	112	70,70
1626206	250 EX 250 R Ninja K8F,K9F,KAF,KBF,KCF	'08→'12	24502-14	16500-43	520	106	111,52
1626203	250 GPX 250 R E,F	'86→'87	24502-14	16500-42	520	104	106,61
1626204	250 GPX 250 R F2,G,F3,F4,F5,F6,F7,F8,F9	'88→'95	24502-14	16500-44	520	106	74,24
1626503	250 KL 250 A2,A3,A4,C1,C2,C3	'80→'85	30300-14	16302-44	520	110	68,61
1626200	250 Z 250 A1,A1,B1,A2	'78→'80	30301-15	16400-35	530	98	104,13
1626201	250 Z 250 A3,A4,B2	'81→'83	24500-15	16400-35	530	98	104,13
1626202	250 ZZR 250 H1,H2,H3,H4,H5,H6, H7,H8,H9,H10,H11,H12,H13,H14	'90→'03	24502-14	16500-47	520	108	116,76
1630201	300 EX 300 Ninja ABS BDF	'13	24502-14	16500-42	520	106	107,77
1630202	300 EX 300 Ninja ABS BEF,BFF,BGF	'14→'16	24502-14	16500-42	520	106	107,77
1630201	300 EX 300 Ninja ADF,AEF,AFF,AGF	'13→'16	24502-14	16500-42	520	106	107,77



KIT AFAM / AFAM KIT

Codice Kit Code	Applicazione Application	Anno Year	Pignone F. Sprocket	Corona R. Sprocket	Passo Pitch	Mg. Nm	€
1630202	300 EX 300 Ninja Special Edition ABS BEFA,BFFA,BGFA	'14→'16	24502-14	16500-42	520	106	107,77
1630201	300 EX 300 Ninja Special Edition AEFA, AFFA,AGFA	'14→'16	24502-14	16500-42	520	106	107,77
1630551	300 KLE 300 Versys-X ABS CHF,CJF	'17→'18	24502-14	16500-46	520	112	116,31
1630551	300 KLE 300 Versys-X BHF,BJF	'17→'18	24502-14	16500-46	520	112	116,31
1630132	300 Z 300 ER 300 Ninja ABS BFF, BGF,BGFA	'15→'16	24502-14	16500-42	520	106	107,77
1630131	300 Z 300 2015-2016	'15→'16	24502-14	16500-42	520	106	107,77
1630200	305 GPZ 305 A1,B2,B3,B4,B5,B6,B7, B,B8,B,B9,B10,B,B	83→'96	24500-15	16400-35	530	102	117,92
1643243	400 EX 400 Ninja ABS GJFA	'18	27500-14	16500-41	520	106	103,89
1643243	400 EX 400 Ninja GJF	'18	27500-14	16500-41	520	106	103,89
1643203	400 GPZX 400	'84→'87	24501-16	16606-43	520	106	112,83
1643300	400 KH 400 A3,A4,A5	'76→'78	24400-14	16400-41	530	104	115,37
1643300	400 S3 400	'74→'75	24400-14	16400-41	530	104	115,37
1643131	400 ER 400 Z	'19→'20	24502-14	16500-41	520	106	107,77
1643200	400 Z 400 B1,B2,B3	'78→'80	24401-15	16400-44	530	100	114,60
1643161	400 Z 400 G1	'79	24401-15	16400-45	530	104	118,80
1643201	400 Z 400 KZ400J J1,J2,J2,J3	'80→'83	24500-16	16401-40	530	100	110,75
1643161	400 Z 400 LTD	'77	24401-15	16400-45	530	104	118,80
1643202	400 ZR 400 Z400F A1,B1	'83→'85	24500-16	16402-40	530	104	113,13
1643205	400 ZR 400 Zephyr G2,G3,G3A,G4,G5	'97→'01	24501-16	16500-42	520	108	110,25
1649200	440 Z 440 C1,C2,H1,H2	'80→'83	24401-15	16400-44	530	104	128,63
1649161	440 Z 440 LTD A2,D4,D5,D6	'79→'84	24401-15	16400-45	530	104	130,45
1659161	500 EN 500 B1,A5,A6,B2,C1,A7,C2, C3, C4,C5,C6,C7,C8,C9,C10,C6F, C7F,C8F,C9F	'94→'09	24501-16	16404-42	520	110	108,33
1659204	500 ER 5 ER500 A1,A2,A3,A4,C1,C2, C3,C4P,C5P,C,C	'97→'07	24501-17	16500-42	520	106	109,63
1659202	500 GPZ 500 S EX 500 A1,A2,B1,A3, B2,B3,A4,A5,B4,B5,A6,A7,B6	'87→'93	24501-16	16500-42	520	104	107,94
1659203	500 GPZ 500 S EX 500 E1,D1,E2,D2, E3,D3,D4,E4,E5,D5,D6,E6,E7,D7,E8, D8,E9,E10,E11	'94→'04	24501-16	16500-41	520	104	107,94
1659300	500 H1 500 D	'73→'73	24400-14	16401-42	530	104	115,37
1659300	500 H1 500 Mach 3 A,B	'69→'72	24400-14	16401-42	530	104	115,37
1659300	500 H2 500 E	'74	24400-14	16401-42	530	104	115,37
1659300	500 H3 500 F	'75→'75	24400-14	16401-42	530	104	115,37
1659300	500 KH 500 A8	'76→'76	24400-14	16401-42	530	104	115,37
1659551	500 KLE 500 A1,A2,A3,A4,A5	'91→'95	24501-16	16600-44	520	108	110,99
1659552	500 KLE 500 A6,A7,A8,A9,A10,A11, A12,A13,A14	'96→'04	24501-17	16600-46	520	110	113,96
1659553	500 KLE 500 B1P,B6F,B7F	'05→'07	24501-17	16600-44	520	108	111,51
1659502	500 KLR 500 B2	'90→'90	24505-15	16600-46	520	108	115,15
1659501	500 KLR 500 KL500 A1,A2,A3	'87→'89	24501-15	16600-46	520	108	111,51
1659161	500 VN 500 Vulcan LTD C7	'02	24501-16	16404-42	520	110	108,33
1659201	500 Z 500 B3	'81	24500-16	16402-40	530	100	110,75
1659206	500 ZZR 500 ZX500 C1,C2,C3	'90→'92	28400-15	16603-48	530	110	125,97
1668200	550 GPZ 550 D1	'81	24500-16	16402-38	530	100	107,60
1668201	550 GPZ 550 H1,H2	'82→'83	24500-16	16402-38	530	104	109,98
1668204	550 Z 550 A1,A2,A3	'80→'82	24500-16	16401-40	530	100	110,75
1668205	550 Z 550 B2,B3	'81→'82	24500-16	16402-40	530	100	110,75
1668161	550 Z 550 LTD C,C,C,C,C	'80→'84	24500-16	16402-38	530	100	107,60
1668203	550 ZR 550 Zephyr B1,B2,B3,B4,B5,B6, B7,B8,B8,B9	'90→'99	24501-16	16500-38	520	106	105,36
1670200	600 GPX 600 R ZX 600 C1,C2,C3,C4,	'88→'97	24500-15	16502-39	530	102	122,43



KIT AFAM / AFAM KIT

Codice Kit Code	Applicazione Application	Anno Year	Pignone F. Sprocket	Corona R. Sprocket	Passo Pitch	Mg. Nm	€
	C5,C6,C7,C8,C9,C10						
1670206	600 GPZ 600 R ZX 600 A1,A2,A3,A4,A5A	'85→'89	24500-15	16502-39	530	102	122,43
1670241	600 ZX 6 R F1,F2,F3	'95→'97	24506-15	16605-40	525	108	127,41
1670242	600 ZX 6 R G1,G2,J1,J2	'98→'01	24508-15	16610-40	525	108	130,80
1670247	600 ZX 6 R P7F,P8F,R9F,RAF,RBF, RCF,RDF,REF,RFF,RGF	'07→'16	21601-16	16606-43	520	112	151,52
1670244	600 ZX 6 RR K1,M1	'03→'04	24510-15	16504-40	520	108	115,19
1670246	600 ZX 6 RR N1,N6F,N7F	'05→'07	24510-15	16606-43	520	110	124,33
1670250	600 ZX6-R	'19→'20	21601-15	16606-43	520	112	150,82
1670201	600 ZZR 600 D1,D2,D3,D4	'90→'93	28400-15	16603-45	530	110	134,76
1670202	600 ZZR 600 E1,E2,E3,E4,E5,E6,E7, E8,E9,E10,E11,E12,E13,E6F,E7F	'93→'07	28400-16	16603-48	530	112	140,56
1670249	636 ZX 6 R ZX636 30th Anniversary Edition ABS FFFA	'15	21601-16	16606-43	520	112	151,52
1670248	636 ZX 6 R ZX636 30th Anniversary Edition EFFA	'15	21601-16	16606-43	520	112	151,52
1670242	636 ZX 6 R ZX636 A1P	'02→'02	24508-15	16610-40	525	108	130,80
1670249	636 ZX 6 R ZX636 ABS FDF,FEF,FFF, FGF,FHF,FJF	'13→'18	21601-16	16606-43	520	112	151,52
1670243	636 ZX 6 R ZX636 B1,B2	'03→'04	24510-15	16504-40	520	108	115,19
1670245	636 ZX 6 R ZX636 C1,C6F	'05→'06	24510-15	16606-43	520	110	124,33
1670248	636 ZX 6 R ZX636 EDF,EEF,EFF,EGF, EHF,EJF	'13→'18	21601-16	16606-43	520	112	151,52
1670249	636 ZX 6 R ZX636 Special Edition ABS FGFA,FHFA,FJFA	'16→'18	21601-16	16606-43	520	112	151,52
1670248	636 ZX 6 R ZX636 Special Edition EGFA,EHFA,EHJA	'16→'18	21601-16	16606-43	520	112	151,52
1673162	650 EN 650 Vulcan S Sp.ciale Edition ABS DHFA,DJFA	'17→'18	27500-15	16606-46	520	120	122,68
1673163	650 EN 650 Vulcan S ABS BFF,BGF, BGFA,BGFB,DHF,EHF,DJF,EJF	'15→'18	27500-15	16606-46	520	120	122,68
1673162	650 EN 650 Vulcan S AFF,AGF,AGFA,CHF	'15→'17	27500-15	16606-46	520	120	122,68
1670203	650 ER 6 F EX650 A5F,A6F,A7F,A8F, C9F,CAF,CBF,ECF,EDF,EEF,EFF,EGF	'05→'16	27500-15	16606-46	520	114	119,00
1670205	650 ER 6 F EX650 ABS B6F,B7F,B8F, D9F,DAF,DBF,FCF,FDF,FEF	'06→'14	27500-15	16606-46	520	114	119,00
1670203	650 ER 6 F EX650 ABS FFF,FGF	'15→'16	27500-15	16606-46	520	114	119,00
1670100	650 ER 6 N ER650 A6F,A7F,A8F,C9F, CAF,CBF,ECF,EDF,EEF,EFF,EGF	'06→'16	27500-15	16606-46	520	114	119,00
1670101	650 ER 6 N ER650 ABS B6F,B7F,B8F, D9F,DAF,DBF,FCF,FDF,FEF,FFF,FGF	'06→'16	27500-15	16606-46	520	114	119,00
1673551	650 KLE 650 Versys	'07→'16	27500-15	16606-46	520	114	119,00
1673552	650 KLE 650 Versys ABS	'07→'16	27500-15	16606-46	520	114	119,00
1673551	650 KLE 650 Versys ABS	'17→'18	27500-15	16606-46	520	114	119,00
1673551	650 KLE 650 Versys Edition Speciale ABS	'17→'18	27500-15	16606-46	520	114	119,00
1673504	650 KLR 650 KL650	'06→'14	24505-15	16600-43	520	106	117,36
1673503	650 KLR 650 KL650	'95→'04	24505-15	16600-42	520	106	113,58
1673241	650 NINJA 650 EX650 ABS	'17→'18	27500-15	16606-46	520	114	151,10
1673241	650 NINJA 650 EX650 JHF	'17	27500-15	16606-46	520	114	151,10
1673131	650 W 650 EJ650	'99→'06	28401-15	16605-39	525	104	117,64
1673200	650 Z 650 B1,B2,B3	'77→'79	24504-16	16401-42	530	102	124,92
1673205	650 Z 650 ER650 ABS HHF,HJF	'17→'18	27500-15	16606-46	520	114	151,10
1673205	650 Z 650 ER650 GHF	'17	27500-15	16606-46	520	114	151,10
1673204	650 Z 650 F2,F3,F4	'81→'83	33600-13	16601-34	630	84	180,46
1673202	650 Z 650 SR D2,D3	'79→'80	24504-16	16402-40	530	102	123,31
1675200	700 Z 700	'87	33600-13	16601-33	630	88	184,07
1677206	750 GPX 750 R ZX 750 F1,F2,F3,F4	'87→'90	28400-16	16701-47	530	110	139,13
1677205	750 GPZ 750 R G2,G3,G4	'85→'87	24601-16	16701-49	530	112	142,31
1677202	750 GPZ 750 R1	'82→'82	33600-13	16601-33	630	88	184,07



KIT AFAM / AFAM KIT

Codice Kit Code	Applicazione Application	Anno Year	Pignone F. Sprocket	Corona R. Sprocket	Passo Pitch	Mg. Nm	€
1677300	750 KH 750 H2 Mach IV	'72→'75	24400-15	16602-47	530	120	147,67
1677200	750 Z 750 KZ750 B1,B2,B3	'77→'79	24504-16	16402-38	530	106	123,07
1677201	750 Z 750 KZ750 E1,L1,L2	'80→'82	33600-13	16601-33	630	84	178,43
1677202	750 Z 750 KZ750 L3,L4	'83→'84	33600-13	16601-33	630	88	184,07
1677215	750 Z 750 R ABS PBF,PCF	'11→'12	24603-15	16606-43	520	112	159,78
1677214	750 Z 750 R Black Edition NBFA	'12	24603-15	16606-43	520	112	159,78
1677214	750 Z 750 R NBF,NCF	'11→'12	24603-15	16606-43	520	112	159,78
1677212	750 Z 750 S K1,K6F,K7F	'05→'07	24603-15	16606-43	520	112	128,25
1677213	750 Z 750 ZR 750 ABS M7F,M8F,M9F, MAF,MBF,MCF,MDF	'07→'13	24603-15	16606-43	520	112	159,78
1677210	750 Z 750 ZR 750 J1,J2,J6F,L7F,L8F, L9F,LAF,LBF,LCF,LDF	'04→'13	24603-15	16606-43	520	112	128,25
1677211	750 ZR 7 S ZR 750 H1,H2,H3,H4,H5	'01→'05	28401-16	16605-38	525	108	118,45
1677209	750 ZR 7 ZR 750 F1,F2,F3,F4,F5,F6	'99→'04	28401-16	16605-38	525	108	118,45
1677207	750 ZR 750 Zephyr C1,C2,C3,C4	'91→'94	28401-15	16605-39	525	106	119,08
1677208	750 ZR 750 Zephyr C5,D1,D2,D3	'95→'98	24602-15	16605-39	525	106	125,66
1677245	750 ZX 7 R ZX750 P1,P2,P3,P4,P5,P6, P7,P8F	'96→'03	28401-16	16610-43	525	110	130,97
1677373	750 ZX 7 RR ZX750 N1,N2,N,N	'96→'99	28401-16	16610-42	525	110	126,88
1677371	750 ZXR 750 R K1	'92	28400-16	16604-42	530	108	129,26
1677372	750 ZXR 750 R M2,M,M	'93→'95	28400-16	16604-41	530	108	129,26
1677241	750 ZXR 750 ZX750 H1	'89	28400-16	16603-46	530	112	137,06
1677242	750 ZXR 750 ZX750 H2	'90	28400-16	16604-46	530	112	137,06
1677243	750 ZXR 750 ZX750 J1,J2	'91→'92	28400-16	16604-45	530	110	135,63
1677244	750 ZXR 750 ZX750 L1,L2,L3	'93→'95	28400-16	16604-44	530	110	133,81
1680161	800 VN 800 A1,A2	'95→'96	28400-16	16603-46	530	114	138,53
1680164	800 VN 800 A3,A4,A5,A6,A7,A8,A9,A10	'97→'04	28400-17	16603-42	530	114	134,12
1680162	800 VN 800 Classic B1,B2,B3,B4,B5,B6, B7,B8,B9,B10,B6F	'96→'06	28400-17	16603-42	530	112	132,65
1680163	800 VN 800 Drifter C1,C2,E1,E2,E3,E4, E5,E6F	'99→'06	28400-17	16603-40	530	112	131,04
1680100	800 W 800 EJ800 + Cafe Style	'11→'11	27500-15	16404-37	520	104	130,28
1680100	800 W 800 EJ800 Special Edition ACFA,AEDF	'12→'14	27500-15	16404-37	520	104	130,28
1680101	800 W 800 STREET-CAFE	'19→'20	27500-15	16600-37	520	104	100,53
1680134	800 Z 800 e ZR800 + ABS + SPECIAL EDITION	'13→'16	24603-15	16606-45	520	114	162,93
1680131	800 Z 800 ZR800 ADS,AEF,AFF,AGF	'13→'16	24603-15	16606-45	520	114	162,93
1686202	900 GPZ 900 R A1,A2,A3,A4,A5,A6	'84→'89	24601-17	16701-49	530	112	142,84
1686204	900 GPZ 900 R A7,A8,A9,A10,A11, A12,A13	'90→'96	24601-17	16701-48	530	112	141,09
1686201	900 Z 900	'72	24800-15	16601-33	630	92	192,86
1686205	900 Z 900 A4	'77	24800-15	16700-35	630	92	198,84
1686207	900 Z 900 RS ABS	'18	28405-15	16610-42	525	114	157,33
1686207	900 Z 900 RS	'18	28405-15	16610-42	525	114	157,33
1686200	900 Z 900 Z1,Z1A,Z1B	'74→'76	33600-15	16700-35	630	92	196,95
1686206	900 Z 900 ZR900 ABS	'17→'18	28405-15	16610-44	525	114	161,42
1686206	900 Z 900 ZR900 AHF,AJF	'17→'18	28405-15	16610-44	525	114	161,42
1686241	900 ZX 9 R ZX900 B1,B2,B3,B4	'94→'97	28400-16	16604-44	530	112	168,00
1686242	900 ZX 9 R ZX900 C1,C2,E1,E2	'98→'01	28400-16	16604-41	530	110	162,86
1686243	900 ZX 9 R ZX900 F1,F2,F3	'02→'04	28405-16	16610-41	525	110	154,35
1689217	1000 H2 1000 SE ZX1000 Ninja B1F	'18	24902-18	16804-44	525	120	212,25
1689217	1000 H2 1000 SX ZX1000 Ninja A1F	'18	24902-18	16804-44	525	120	212,25
1689247	1000 H2 1000 ZX1000 Ninja	'15→'18	24902-18	16804-44	525	118	209,83
1689551	1000 KLV 1000 LV1000	'04→'05	28401-17	14604-41	525	112	154,63
1689552	1000 KLZ 1000 Versys	'12→'18	28405-15	16610-43	525	116	163,28
1689209	1000 Z 1000	'77→'78	24800-15	16601-33	630	92	192,86
1689201	1000 Z 1000	'81→'83	24801-15	16601-41	630	96	216,97
1689210	1000 Z 1000 MK2 A3	'79	24800-15	16601-33	630	94	195,66
1689209	1000 Z 1000 MK2 A4	'80	24800-15	16601-33	630	92	192,86



KIT AFAM / AFAM KIT

Codice Kit Code	Applicazione Application	Anno Year	Pignone F. Sprocket	Corona R. Sprocket	Passo Pitch	Mg. Nm	€
1689215	1000 Z 1000 R ZR 1000 JHF,JJF	'17→'18	28405-15	16610-43	525	112	190,19
1689202	1000 Z 1000 R2	'83	24801-15	16601-41	630	98	219,70
1689214	1000 Z 1000 SX ZX1000 ABS HBF, HCF,HDF,MEF,MFF,MGF	'11→'16	28405-15	16610-41	525	112	186,10
1689213	1000 Z 1000 SX ZX1000 GBF,GCF, GDF,LEF,LFF,LGF,WHF,WJF	'11→'18	28405-15	16610-41	525	112	186,10
1689209	1000 Z 1000 Z1R D1,D3	'78→'79	24800-15	16601-33	630	92	192,86
1689205	1000 Z 1000 ZR 1000 A1,A2,A3,A6F	'03→'06	28405-16	16610-42	525	112	156,24
1689208	1000 Z 1000 ZR 1000 ABS C7F,C8F,C9F	'07→'09	28405-15	16610-40	525	110	152,25
1689212	1000 Z 1000 ZR 1000 ABS EAF,EBF, ECF,EDF	'10→'13	28405-15	16610-42	525	112	155,44
1689216	1000 Z 1000 ZR 1000 ABS GEF,GEFA, GFF,GGF	'14→'16	28405-15	16610-43	525	112	190,19
1689207	1000 Z 1000 ZR 1000 B7F,B8F,B9F	'07→'09	28405-15	16610-40	525	110	152,25
1689211	1000 Z 1000 ZR 1000 DAF,DBF,DCF, DCFA,DDFA,DDF	'10→'13	28405-15	16610-42	525	112	155,44
1689215	1000 Z 1000 ZR 1000 FEF,FEFA,FFF, FGF,HHF,HJF	'14→'18	28405-15	16610-43	525	112	190,19
1689218	1000 Z 1000 R	'19→'20	28405-15	16610-43	525	112	190,19
1689245	1000 ZX 10 R ZX 1000 30th Anniversary Edition ABS KFFA	'15	28401-17	16610-39	525	112	184,00
1689244	1000 ZX 10 R ZX 1000 30th Anniversary Edition JFFA	'15	28401-17	16610-39	525	112	184,00
1689246	1000 ZX 10 R ZX 1000 ABS + KRT REPLICA	'16→'18	28401-17	16610-39	525	114	186,38
1689245	1000 ZX 10 R ZX 1000 ABS KBF,KCF, KDF,KEF,KFF	'11→'15	28401-17	16610-39	525	112	184,00
1689241	1000 ZX 10 R ZX 1000 C1,C2	'04→'05	28401-17	16610-39	525	110	151,45
1689242	1000 ZX 10 R ZX 1000 D6F,D7F	'06→'07	28401-17	16610-40	525	108	149,56
1689243	1000 ZX 10 R ZX 1000 E8F,E9F,FAF	'08→'10	28401-17	16610-41	525	110	152,74
1689244	1000 ZX 10 R ZX 1000 JBF,JCF,JDF, JEF,JFF	'11→'15	28401-17	16610-39	525	112	184,00
1689204	1000 ZX 10 ZX 1000 B1,B2,B3	'88→'90	24805-17	16701-45	530	110	179,87
1692205	1100 GPZ 1100 ABS F1,F,F	'96→'98	24900-17	16701-45	530	112	175,32
1692208	1100 GPZ 1100 B1	'82→'82	24801-15	16601-41	630	98	219,70
1692205	1100 GPZ 1100 E1,E2,E3,E4,E	'95→'99	24900-17	16701-45	530	112	175,32
1692209	1100 Z 1100 Lawson Replica R1	'84	24801-15	16601-41	630	98	219,70
1692203	1100 ZR 1100 Zephyr A1,A2,A3,A4, B1,B2,B5	'92→'02	24601-16	16701-48	530	116	177,38
1692207	1100 ZRX 1100 ZR 1100 C1,D1,D2,C2, C3,D3,D4,C4	'97→'00	24900-17	16701-45	530	110	173,29
1692202	1100 ZZR 1100 ZX 1100 C1,C2,C3	'90→'92	24806-17	16701-45	530	110	184,63
1692204	1100 ZZR 1100 ZX 1100 D1,D2,D3	'93→'95	24601-17	16701-45	530	110	168,32
1692206	1100 ZZR 1100 ZX 1100 D4,D5,D6, D7,D8,D9	'96→'01	24601-17	16701-44	530	110	166,50
1695200	1200 ZRX 1200 R ZR 1200 A1,A2, A3,A4,A5,A6F,A7F,A8F	'01→'08	24900-17	16604-42	530	110	215,92
1695202	1200 ZRX 1200 S ZR 1200 B1,B2, B3,B4,B,B,B	'01→'07	24900-17	16604-42	530	110	215,92
1695241	1200 ZX 12 R A1,A2,B1,B2,B3,B4,B6F	'00→'06	24601-18	16604-46	530	116	225,27
1695201	1200 ZZR 1200 ZX1200 C1,C2,C3,C4	'02→'05	24601-17	16604-44	530	112	216,97
1698202	1400 ZZR 1400 Performance Sport ABS JGF,JHF,JJF	'16→'18	24601-17	16900-42	530	118	222,50
1698200	1400 ZZR 1400 ZX 1400 A6F,A7F,A8F	'06→'08	24601-17	16900-41	530	116	219,63
1698201	1400 ZZR 1400 ZX 1400 ABS B6F, B7F,D8F,D9F,DAF,DBF	'06→'11	24601-17	16900-41	530	116	219,63
1698202	1400 ZZR 1400 ZX 1400 ABS FCF, FDFA,FDG,FDH,FEF,FFF,HGF,HHF,HJF	'12→'18	24601-17	16900-42	530	118	222,50
1698202	1400 ZZR 1400 ZX 1400 Special Edition ABS FFFA	'15	24601-17	16900-42	530	118	222,50



KIT AFAM / AFAM KIT

Codice Kit Code	Applicazione Application	Anno Year	Pignone F. Sprocket	Corona R. Sprocket	Passo Pitch	Mg. Nm	€
KAWASAKI CORONE ALLUMINIO + TRASFORMAZIONE # 520							
1770401	600 ZX 6 R F1,F2,F3	'95→'97	24507-15	17404-40	520	108	168,88
1770402	600 ZX 6 R G1,G2,J1,J2	'98→'01	24509-15	17606-40	520	108	168,32
1770407	600 ZX 6 R P7F,P8F,R9F,RAF,RBF,RCF, RDF,REF,RFF,RGF	'07→'16	24511-16	17606-43	520	112	175,28
1770410	600 ZX 6 RR K1,M1	'03→'04	24509-15	17606-40	520	108	168,32
1770404	600 ZX 6 RR N1,N6F,N7F	'05→'07	24509-15	17606-43	520	110	178,54
1770410	636 ZX 6 R ZX636 A1P	'02	24509-15	17606-40	520	108	168,32
1770411	636 ZX 6 R ZX636 B1,B2	'03→'04	24509-15	17606-40	520	108	168,32
1770403	636 ZX 6 R ZX636 C1,C6F	'05→'06	24509-15	17606-43	520	110	178,54
1770409	636 ZX 6 R ZX636 Special Edition + ABS + 30TH ANN.	'13→'18	24511-16	17606-43	520	112	175,28
1770412	636 ZX6-R	'19→'21	24511-15	17606-43	520	112	174,58
1773241	650 NINJA 650 EX650 ABS KHFA, KHF,KJFA,KJF	'17→'18	27500-15	17606-46	520	114	175,39
1777210	750 Z 750 ZR 750 J1,J2,J6F,L7F,L8F, L9F,LAF,LBF,LCF,LDF	'04→'13	24603-15	17606-43	520	112	183,54
1777405	750 ZX 7 R ZX750 P1,P2,P3,P4,P5, P6,P7,P8F	'96→'03	28404-16	17606-43	520	110	174,38
1777406	750 ZX 7 RR ZX750 N1,N2,N,N	'96→'99	28404-16	17606-42	520	110	171,61
1777401	750 ZXR 750 ZX750 H1	'89	28402-16	17404-46	520	112	178,43
1777402	750 ZXR 750 ZX750 H2	'90	28402-16	17606-46	520	112	178,43
1777403	750 ZXR 750 ZX750 J1,J2	'91→'92	28402-16	17606-45	520	110	176,65
1777404	750 ZXR 750 ZX750 L1,L2,L3	'93→'95	28402-16	17606-44	520	110	174,76
1780131	800 Z 800 ZR800 ABS BDS,BEF,BFF,BGF	'13→'16	24603-15	17606-45	520	114	187,22
1780131	800 Z 800 ZR800	'13→'16	24603-15	17606-45	520	114	187,22
1786401	900 ZX 9 R ZX900	'94→'97	28402-16	17606-44	520	112	207,48
1786402	900 ZX 9 R ZX900	'98→'01	28402-16	17606-41	520	110	199,58
1786402	900 ZX 9 R ZX900	'02→'04	28402-16	17606-41	520	110	199,58
1789411	1000 Z 1000 R ZR 1000	'17→'18	28402-15	17606-43	520	112	206,68
1789411	1000 Z 1000 ZR 1000 + abs	'14→'18	28402-15	17606-43	520	112	206,68
1789405	1000 Z 1000 ZR 1000	'03→'06	28402-16	17606-42	520	112	204,72
1789406	1000 Z 1000 ZR 1000	'07→'09	28402-15	17606-40	520	110	195,90
1789409	1000 Z 1000 ZR 1000	'10→'13	28402-15	17606-42	520	112	203,91
1789410	1000 ZX 10 R ZX 1000 30th Anniversary Edition ABS	'15	28404-17	17606-39	520	112	199,26
1789410	1000 ZX 10 R ZX 1000 30th Anniversary Edition JFFA	'15	28404-17	17606-39	520	112	199,26
1789410	1000 ZX 10 R ZX 1000 ABS	'11→'15	28404-17	17606-39	520	112	199,26
1689410	1000 ZX 10 R STEEL #520 RACING	'11→'15	28404-17	16606RLK-39	520	112	193,38
1789412	1000 ZX 10 R ZX 1000 ABS+ 2016 ktr replica + versione RR	'18	28404-17	17606-39	520	114	201,61
1789401	1000 ZX 10 R ZX 1000	'04→'05	28404-17	17606-39	520	110	196,92
1789404	1000 ZX 10 R ZX 1000	'06→'07	28404-17	17606-40	520	108	194,54
1789408	1000 ZX 10 R ZX 1000	'08→'10	28404-17	17606-41	520	110	199,79
1789410	1000 ZX 10 R ZX 1000	'11→'15	28404-17	17606-39	520	112	199,26
1689412	1000 ZX 10 R STEEL #520 RACING	'16→'20	28404-17	16606RLK-39	520	114	195,72
KTM							
7121200	200 RC 200	'14→'15	73203-14	71202-42	520	110	109,41
7121636	200 200 DUKE	'12→'13	73203-14	10221-42	520	110	106,37
7121637	200 200 DUKE	'14→'20	73203-14	71202-42	520	110	109,41
7141636	390 390 Duke ABS	'14→'18	73305-15	71202-45	520	112	120,27
7141551	390 390 ADVENTURE	'20	73305-15	71202-45	520	116	122,55
7141241	390 RC 390	'14→'17	73305-15	71202-45	520	112	120,27



KIT AFAM / AFAM KIT

Codice Kit Code	Applicazione Application	Anno Year	Pignone F. Sprocket	Corona R. Sprocket	Passo Pitch	Mg. Nm	€
7143636	400 400 LC4 Duke	'94→'98	73303-16	71304-42	520	108	121,53
7172636	620 620 Duke	'93→'93	73303-17	71304-38	520	106	106,72
7172636	620 620 LC4 Duke	'94→'99	73303-17	71304-38	520	106	106,72
7173700	640 640 Adventure	'05→'07	73303-16	71304-42	520	110	112,08
7173700	640 640 Adventure-R	'98→'04	73303-16	71304-42	520	110	112,08
7173636	640 640 Duke II	'98→'03	73303-16	71304-38	520	106	105,92
7173641	640 640 Duke II	'04→'07	73303-17	71304-42	520	108	111,65
7173700	640 640 LC-4 640 Adventure	'03→'06	73303-16	71304-42	520	110	112,08
7173703	640 640 LC4-E Enduro	'00→'02	73303-16	71304-42	520	110	112,08
7173637	640 640 LC4 Supermoto	'99→'01	73303-17	71304-40	520	108	110,53
7173639	640 640 LC4 Supermoto	'02→'06	73303-17	71304-42	520	110	112,88
7173640	660 660 SMC	'02→'04	73303-16	71304-38	520	110	108,37
7173642	660 660 SMC	'05→'06	73303-17	71304-40	520	110	111,76
7173701	660 660 RALLY 2001	'01→'01	73303-16	71304-44	520	112	117,08
7173702	660 660 RALLY FACTORY	'02→'03	73303-16	71304-44	520	116	119,54
7175701	690 690 RALLY	'07→'08	73303-16	71304-44	520	116	119,54
7175702	690 690 Enduro R	'18→'20	73303-15	71304-46	520	116	120,69
7175638	690 690 Duke	'08→'12	73303-16	71304-40	520	114	113,44
7175638	690 690 Duke ABS	'13→'17	73303-16	71304-40	520	114	113,44
7175638	690 690 R Duke R	'10→'12	73303-16	71304-40	520	114	113,44
7175638	690 690 R Duke R ABS	'13→'17	73303-16	71304-40	520	114	113,44
7175636	690 690 Supermoto	'07→'08	73303-16	71304-40	520	114	113,44
7175636	690 690 Supermoto Limited Edition	'09→'09	73303-16	71304-40	520	114	113,44
7175637	690 SMC 690	'08→'11	73303-16	71304-42	520	116	115,79
7175637	690 SMC 690 R	'12→'13	73303-16	71304-42	520	116	115,79
7175637	690 SMC 690 R ABS	'14→'17	73303-16	71304-42	520	116	115,79
7175700	690 690 Enduro	'08→'16	73303-15	71304-45	520	116	120,09
7180551	790 790 ADVENTURE 2019-2020	'19→'20	73303-16	71304-45	520	118	122,12
7180636	790 790 DUKE 2018-2020	'18→'20	73303-16	71304-41	520	116	115,68
7186636	890 890 DUKE R	'20	73303-16	71304-41	520	116	115,68
7187551	950 950 Adventure	'02→'05	61800-17	71800-42	525	118	166,99
7187551	950 950 Adventure S	'03→'06	61800-17	71800-42	525	118	166,99
7187637	950 950 R Supermoto	'07→'08	61800-17	71801-41	525	112	161,35
7187636	950 950 Supermoto	'05→'08	61800-17	71801-41	525	112	161,35
7189551	990 990 Adventure ABS	'06→'12	61800-16	71800-42	525	118	165,66
7189551	990 990 Adventure Dakar Edition ABS	'11	61800-16	71800-42	525	118	165,66
7189551	990 990 Adventure Limited Edition ABS	'10	61800-16	71800-42	525	118	165,66
7189551	990 990 R Adventure R	'09→'12	61800-16	71800-42	525	118	165,66
7189636	990 990 R Super Duke R	'07→'13	61800-16	71801-38	525	110	154,18
7189551	990 990 S Adventure S	'06→'08	61800-16	71800-42	525	118	165,66
7189636	990 990 Super Duke	'05→'12	61800-16	71801-38	525	110	154,18
7189639	990 SM 990 R Supermoto R	'08→'12	61800-17	71801-41	525	112	161,35
7189639	990 SM 990 R Supermoto R ABS	'13	61800-17	71801-41	525	112	161,35
7189637	990 SM 990 Supermoto	'08→'10	61800-17	71801-41	525	112	161,35
7189638	990 SM 990 T Supermoto T	'09→'10	61800-17	71801-41	525	112	161,35
7189638	990 SM 990 T Supermoto T ABS	'11→'13	61800-17	71801-41	525	112	161,35
7190551	1050 1050 Adventure	'15→'16	61800-17	71800-42	525	118	199,29
7195551	1190 1090 Adventure R	'13→'17	61800-17	71800-42	525	118	199,29
7192551	1090 1090 Adventure + R + ABS	'17→'18	61800-17	71800-42	525	118	199,29
7195241	1190 RC 8	'08→'11	61800-17	71801-37	525	108	183,20
7195242	1190 RC 8 R	'09→'15	61800-17	71801-38	525	108	183,20



KIT AFAM / AFAM KIT

Codice Kit Code	Applicazione Application	Anno Year	Pignone F. Sprocket	Corona R. Sprocket	Passo Pitch	Mg. Nm	€
7197551	1290 1290 R SuperAdventure	'17	61800-17	71800-42	525	118	199,29
7197636	1290 1290 R Superduke R ABS +SE	'14→'17	61800-17	71900-38	525	112	191,10
7197551	1290 1290 SuperAdventure + S + T	'15→'18	61800-17	71800-42	525	118	199,29
7197636	1290 1290 Superduke GT ABS	'17	61800-17	71900-38	525	112	191,10

KTM CORONE ALLUMINIO + TRASFORMAZIONE # 520

7272636	620 620 Duke	'93	73303-17	72304N-38	520	106	125,76
7272636	620 620 LC4 Duke	'94→'99	73303-17	72304N-38	520	106	125,76
7273700	640 640 Adventure	'05→'07	73303-16	72304N-42	520	110	131,29
7273700	640 640 Adventure-R	'98→'04	73303-16	72304N-42	520	110	131,29
7273636	640 640 Duke II	'98→'03	73303-16	72304N-38	520	106	124,96
7273641	640 640 Duke II	'04→'07	73303-17	72304N-42	520	108	130,87
7273703	640 LC4-E 640 Enduro	'00→'02	73303-16	72304N-42	520	110	131,29
7273700	640 LC-4 640 Adventure	'03→'06	73303-16	72304N-42	520	110	131,29
7273637	640 LC4 640 Supermoto	'92→'02	73303-17	72304N-40	520	108	127,16
7273639	640 Supermoto 640	'05→'06	73303-17	72304N-42	520	108	132,10
7273640	660 660 SMC	'02→'04	73303-16	72304N-38	520	110	127,41
7273642	660 660 SMC	'05→'06	73303-17	72304N-40	520	110	128,39
7275638	690 690 Duke	'08→'12	73303-16	72304N-40	520	114	130,06
7275638	690 690 Duke ABS	'13→'17	73303-16	72304N-40	520	114	130,06
7275638	690 690 R Duke R	'10→'12	73303-16	72304N-40	520	114	130,06
7275638	690 690 R Duke R ABS	'13→'17	73303-16	72304N-40	520	114	130,06
7275636	690 690 Supermoto	'07→'08	73303-16	72304N-40	520	114	130,06
7275636	690 690 Supermoto Limited Edition	'09	73303-16	72304N-40	520	114	130,06
7275637	690 SMC 690	'08→'11	73303-16	72304N-42	520	116	135,00
7275637	690 SMC 690 R	'12→'13	73303-16	72304N-42	520	116	135,00
7275637	690 SMC 690 R ABS	'14→'17	73303-16	72304N-42	520	116	135,00
7287636	950 950 Supermoto	'05→'08	61800-17	72801-41	525	112	190,19
7287637	950 950 Supermoto R	'07→'08	61800-17	72801-41	525	112	190,19
7289636	990 990 Super Duke	'06→'13	61800-16	72801-38	525	110	213,69
7289637	990 990 Supermoto	'08→'09	61800-17	72801-41	525	112	220,85
7289638	990 990 SMT	'09→'11	61800-17	72801-41	525	112	220,85
7295241	1190 RC8	'08→'10	61800-17	72801-38	525	108	212,59
7295242	1190 RC8 R	'10→'14	61800-17	72801-38	525	108	212,59

KYMCO

7401100	50 KPW 50	'13→'14	20113-11	10223-43	428	110	35,57
7413164	125 125 Hipster	'99→'05	26200-16	10201-41	428	124	41,52
7413165	125 125 Hipster	'06→'07	26200-16	10201-39	428	124	40,78
7413132	125 125 Pulsar + LUXE	'99→'08	20200-15	10201-39	428	108	38,12
7413134	125 125 Pulsar II	'08→'13	20200-16	10201-41	428	116	40,36
7413101	125 125 R Spike	'04→'06	20107-14	10201-41	428	124	40,99
7413131	125 125 Sector	'97→'01	20200-15	10201-39	428	110	38,37
7413101	125 125 Spike	'00→'06	20107-14	10201-41	428	124	40,99
7413551	125 125 Stryker	'01→'06	26200-16	10223-47	428	126	44,70
7413161	125 125 Zing Custom Style	'97→'06	26200-16	10201-41	428	124	41,52
7413133	125 CK 125 Pulsar	'04→'05	20200-16	10201-39	428	108	38,61
7413135	125 CK1 125	'14→'16	20200-15	10201-38	428	122	38,09
7413102	125 K 125 K-Pipe	'12→'15	20107-14	10201-36	428	110	36,62
7413100	125 KR 125 Quannon Naked	'10→'15	26200-15	74200-42	428	130	42,08
7413200	125 KR 125 Quannon Sport	'07→'13	26200-15	74200-42	428	130	42,08
7415100	150 150 Straight	'08	20107-14	10201-41	428	124	40,99
7413551	150 150 Stryker	'00→'06	26200-16	10223-47	428	126	44,70
7415100	150 150 Straight	'08	20107-14	10201-41	428	124	41,45



KIT AFAM / AFAM KIT

Codice Kit Code	Applicazione Application	Anno Year	Pignone F. Sprocket	Corona R. Sprocket	Passo Pitch	Mg. Nm	€
--------------------	-----------------------------	--------------	------------------------	-----------------------	----------------	-----------	---

7413551	150 150 Stryker	'00→'06	26200-16	10223-47	428	126	45,18
----------------	-----------------	---------	----------	----------	-----	-----	-------

LAVERDA

6877371	750 750 Formula	'98→'99	70600-16	92606-42	520	110	152,08
6877131	750 750 Ghost Strike	'98→'99	70600-16	92606-43	520	110	155,86
6877371	750 750 S	'98→'99	70600-16	92606-42	520	110	152,08
6877371	750 750 S Formula	'00→'01	70600-16	92606-42	520	110	152,08
6877241	750 750 Sport	'00→'01	70600-16	92606-43	520	110	155,86
6877241	750 750 SS	'98→'01	70600-16	92606-43	520	110	155,86
6877131	750 750 Strike	'98→'01	70600-16	92606-43	520	110	155,86

9389200	1000 SF 1000	'85→'86	94803-19	93800-40	530	106	157,61
----------------	--------------	---------	----------	----------	-----	-----	--------

LAVERDA CORONA ALLUMINIO

9377200	750 750 SF 750	'71→'77	94803-19	93800-40	530	106	157,61
----------------	----------------	---------	----------	----------	-----	-----	--------

MALAGUTI

14601131	50 NKD 50 Drakon	'05→'09	94119-11	146100-48	420	126	41,93
14601636	50 XSM 50 Super Motard	'03→'06	94119-11	47103-48	420	126	38,54
14601637	50 XSM 50 Super Motard	'07→'08	94119-11	47103-60	420	132	47,68
14601600	50 XTM 50	'03→'06	94119-11	47103-50	420	126	39,90
14601601	50 XTM 50	'07→'11	94119-11	47103-62	420	134	50,16

14613500	125 X3M 125 Enduro	'08→'10	21200-14	47200-50	428	128	46,56
14613636	125 X3M 125 Motard	'08→'10	21200-14	47200-48	428	126	44,74

MBK

13401610	50 50 X Limit Enduro	'03→'06	94119-11	47103-50	420	126	39,90
13401608	50 50 X Limit Enduro	'97→'02	94109-12	12100-52	420	128	46,10
13401611	50 50 X Limit Enduro	'07→'10	94119-11	47103-62	420	134	50,16
13401638	50 50 X Limit Supermoto	'03→'06	94119-11	47103-48	420	126	38,54
13401636	50 50 X Limit Supermoto	'02	94119-12	35103-50	420	128	43,20
13401639	50 50 X Limit Supermoto	'07→'11	94119-11	47103-60	420	132	47,68
13401637	50 50 X Limit Supermoto	'02	94118-13	35107-50	428	128	46,31
13401242	50 TZR 50 X-Power	'98→'99	94109-12	12112-47	420	132	43,62
13401243	50 TZR 50 X-Power	'00→'02	94119-12	12113-47	420	132	42,92
13401244	50 TZR 50 X-Power	'03→'06	94119-11	12115-47	420	132	38,79
13401245	50 TZR 50 X-Power	'07→'11	94119-11	12115-60	420	138	47,96

MOTO MORINI

9295131	1200 1200 Corsaro	'05→'10	94902-17	92837-40	525	104	177,49
9295131	1200 1200 Corsaro Avio	'08→'09	94902-17	92837-40	525	104	177,49
9295131	1200 1200 Corsaro Veloce	'07→'09	94902-17	92837-40	525	104	177,49
9295551	1200 1200 Granpasso	'08→'10	94902-17	92837-40	525	106	179,94

MV (AGUSTA)

9274241	675 F3 675	'11→'14	94605-16	92836-43	525	114	146,93
9280132	675 F3 675	'15→'18	94605-16	92836-41	525	114	142,84
9274241	675 F3 675 RC	'15→'18	94605-16	92836-43	525	114	146,93
9274241	675 F3 675 Serie Oro	'12→'15	94605-16	92836-43	525	114	146,93

9277131	750 750 Brutale	'01→'02	94603-14	92667-41	520	108	211,09
9277132	750 750 Brutale Oro	'03→'05	94604-14	92667-41	520	108	210,91
9277132	750 750 S Brutale	'03→'05	94604-14	92667-41	520	108	210,91
9277245	750 F4 750 Ago	'04	94604-15	92667-41	520	108	211,44
9277241	750 F4 750 Oro	'99	94603-14	92667-41	520	108	211,09
9277241	750 F4 750 S	'99→'01	94603-14	92667-41	520	108	211,09
9277244	750 F4 750 S	'03→'05	94604-15	92667-41	520	108	211,44
9277242	750 F4 750 S	'02	94603-14	92667-43	520	110	214,77
9277243	750 F4 750 Senna	'02→'03	94604-15	92667-41	520	108	211,44



KIT AFAM / AFAM KIT

Codice Kit Code	Applicazione Application	Anno Year	Pignone F. Sprocket	Corona R. Sprocket	Passo Pitch	Mg. Nm	€
9277244	750 F4 750 SPR	'03→'04	94604-15	92667-41	520	108	211,44
9280132	800 800 Brutale	'12→'18	94605-16	92836-41	525	114	155,62
9280132	800 800 Brutale Dragster	'14→'15	94605-16	92836-41	525	114	155,62
9280133	800 800 RC Brutale Dragster RC	'17→'18	94605-16	92836-41	525	114	155,62
9280134	800 800 RC Turismo Veloce RC	'17→'18	94605-16	92836-41	525	114	155,62
9280134	800 800 Rivale	'13→'18	94605-16	92836-41	525	114	155,62
9280133	800 800 RR Brutale Dragster RR	'15→'18	94605-16	92836-41	525	114	155,62
9280133	800 800 RR Brutale RR	'15	94605-16	92836-41	525	114	155,62
9280134	800 800 Stradale	'15	94605-16	92836-41	525	114	155,62
9280134	800 800 Turismo Veloce	'15→'18	94605-16	92836-41	525	114	155,62
9280200	800 800 Turismo Veloce Lusso	'15→'18	94605-16	92836-41	525	114	155,62
9280241	800 F3 800	'12→'18	94605-17	92836-41	525	114	157,65
9280241	800 F3 800 Ago	'14→'15	94605-17	92836-41	525	114	157,65
9280241	800 F3 800 RC	'15→'18	94605-17	92836-41	525	114	157,65
9286131	910 910 R Brutale	'05→'08	94807-15	92836-43	525	110	156,10
9286131	910 910 S Brutale	'05→'08	94807-15	92836-43	525	110	156,10
9286134	920 920 Brutale	'10→'12	94807-15	92836-40	525	110	150,71
9287131	989 989 R Brutale	'08→'09	94807-15	92836-43	525	110	156,10
9287132	990 990 R Brutale	'10→'11	94807-15	92836-41	525	110	152,01
9289241	1000 F4 1000	'04→'06	94807-15	92836-40	525	108	148,82
9289242	1000 F4 998	'10→'16	94807-15	92836-41	525	110	152,01
9289241	1000 F4R 1000	'06→'07	94807-15	92836-40	525	108	148,82
9289242	1000 F4R 998	'12→'16	94807-15	92836-41	525	110	152,01
9289241	1000 F4RR 1000 312R	'07	94807-15	92836-40	525	108	148,82
9289243	1000 F4RR 998	'10→'16	94807-15	92836-41	525	110	152,01
9289243	1000 F4RR 998 Corsa Corta	'12→'12	94807-15	92836-41	525	110	152,01
9290132	1078 1078 RR Brutale	'08→'09	94807-15	92836-41	525	110	152,01
9290241	1078 F4RR 1078 312	'08→'09	94807-15	92836-40	525	108	148,82
9290133	1090 1090 Brutale	'13→'15	94807-15	92836-41	525	110	152,01
9290134	1090 1090 Brutale Corsa	'13	94807-15	92836-43	525	112	157,99
9290133	1090 1090 R Brutale	'12→'15	94807-15	92836-41	525	110	152,01
9290131	1090 1090 RR Brutale	'10→'11	94807-15	92836-41	525	110	152,01
9290134	1090 1090 RR Brutale	'12→'16	94807-15	92836-43	525	112	157,99
CORONA ALLUMINIO							
9374241	675 675 F3	'12→'18	94605-16	93836-43	525	114	204,46
9380132	800 BRUTALE 800	'12→'18	94605-16	93836-41	525	114	197,92
9380133	800 BRUTALE 800 DRAGSTER	'14→'18	94605-16	93836-41	525	114	197,92
9380134	800 800 RIVALE	'14→'16	94605-16	93836-41	525	114	197,92
9380241	800 F3 800	'12→'18	94605-17	93836-41	525	114	199,95
9386131	910 910 BRUTALE	'05→'08	94807-15	93836-43	525	110	187,38
9386134	920 920 BRUTALE	'10→'11	94807-15	93836-40	525	110	178,07
9387131	989 989 R BRUTALE	'08→'09	94807-15	93836-43	525	110	187,38
9387132	990 990 R BRUTALE	'10→'11	94807-15	93836-41	525	110	180,84
9389241	1000 F4 / F4R	'05→'08	94807-15	93836-40	525	108	208,70
9389242	1000 F4 / F4R	'10→'16	94807-15	93836-41	525	110	213,95
9389243	1000 F4 1000 RR	'10→'16	94807-15	93836-41	525	110	213,95
9390132	1078 BRUTALE 1078 RR	'08→'09	94807-15	93836-41	525	110	213,95
9390241	1078 1078 F4 R	'08→'09	94807-15	93836-40	525	108	208,70



KIT AFAM / AFAM KIT

Codice Kit Code	Applicazione Application	Anno Year	Pignone F. Sprocket	Corona R. Sprocket	Passo Pitch	Mg. Nm	€
9390131	1090 1090 RR BRUTALE	'10→'11	94807-15	93836-41	525	110	213,95
9390133	1090 BRUTALE 1090 R	'12→'13	94807-15	93836-41	525	110	213,95
9390134	1090 BRUTALE 1090 RR	'12→'16	94807-15	93836-43	525	112	222,98

MZ (MUZ)

8313600	125 RT 125	'01→'07	85200-16	83200-49	428	126	71,65
8313601	125 RT 125	'03→'04	85200-16	83201-49	428	126	46,83
8313600	125 RT 125 Striker	'05→'07	85200-16	83200-49	428	126	71,65
8313636	125 SM 125 Gangsta	'02→'07	85200-16	83201-49	428	132	47,60
8313500	125 SX 125	'02→'07	85200-16	56200-51	428	132	48,62
8373501	660 660 Baghira	'97→'05	21504-15	12505-45	520	110	122,82
8373501	660 660 Baghira - Black Panther	'96→'03	21504-15	12505-45	520	110	122,82
8373501	660 660 Baghira - Forest/ Forest HR	'96→'05	21504-15	12505-45	520	110	122,82
8373501	660 660 Baghira - Street Moto	'96→'05	21504-15	12505-45	520	110	122,82
8373500	660 660 Fun bike	'97→'98	21504-15	12505-45	520	116	126,53
8373502	660 660 Mastiff	'96→'05	21504-15	12505-45	520	116	126,53
8373132	660 660 Skorpion Tour	'95→'02	21504-15	35303-43	520	110	124,50
8373200	660 660 Skorpion Traveller	'98→'02	21504-15	35303-43	520	110	124,50
8373132	660 660 Skorpion Traveller	'00	21504-15	35303-43	520	110	124,50

PEUGEOT

9201101	50 NK 7 Naked	'09→'13	94119-11	92122-60	420	138	55,13
9201601	50 XP6 50 Enduro	'01→'01	94109-12	56103-52	420	126	45,85
9201602	50 XP6 50 Enduro	'02→'03	94119-12	47103-52	420	126	41,34
9201604	50 XP6 50 Enduro	'04→'05	94119-11	47103-52	420	126	41,09
9201644	50 XP6 50 SM	'01	94109-12	56103-52	420	126	45,85
9201645	50 XP6 50 SM	'02→'03	94119-12	47103-52	420	126	41,34
9201639	50 XP6 50 SM Top Road	'04→'06	94119-11	47103-52	420	126	41,09
9201640	50 XP6 50 SM Top Road	'07→'11	94119-11	47103-60	420	132	47,68
9201643	50 XP6 50 SM Top Road	'12	94119-11	92122-60	420	132	54,36
9201610	50 XP6 50 Track	'06	94119-11	47103-52	420	124	40,81
9201607	50 XP6 50 Track	'07→'12	94119-11	47103-62	420	134	50,16
9201642	50 XPS 50 SM	'09	94119-11	47103-60	420	132	47,68
9201638	50 XPS 50 SM Street	'05→'09	94119-11	92122-52	420	126	42,95
9201641	50 XPS 50 SM Top Road	'03→'06	94119-11	47103-52	420	126	41,09
9201642	50 XPS 50 SM Top Road	'07→'12	94119-11	47103-60	420	132	47,68
9201608	50 XPS 50 Track	'03→'06	94119-11	47103-52	420	126	41,09
9201609	50 XPS 50 Track	'07→'12	94119-11	47103-62	420	134	50,16
9201241	50 XR6 50	'01→'07	94119-12	92114-52	420	128	42,50
9201243	50 XR7 50 Full Fairing	'08→'13	94119-11	92122-60	420	138	55,13
9213551	125 XPS 125 CT	'05→'07	21200-14	47200-48	428	124	39,28

RIEJU

8001611	50 50 Spike	'04	94119-11	80105-48	420	124	41,65
8001613	50 50 Spike	'05→'06	94119-11	80105-52	420	126	44,91
8001100	50 50 Tango	'07→'17	94119-11	47103-52	420	128	41,34
8001101	50 50 Tango Motard	'09→'11	94119-11	92122-52	420	128	43,20
8001614	50 MRT 50	'09→'17	94119-11	47103-52	420	132	41,83
8001638	50 MRT 50 Supermotard	'09→'17	94119-11	47103-52	420	132	41,83
8001642	50 MRT 50 Supermotard	'11	94119-11	92122-52	420	132	43,69
8001614	50 MRT-Pro 50	'09→'17	94119-11	47103-52	420	132	41,83
8001638	50 MRT-Pro 50 Supermotard	'09→'13	94119-11	47103-52	420	132	41,83
8001642	50 MRT-Pro 50 Supermotard	'11	94119-11	92122-52	420	132	43,69
8001615	50 MRT	'17→'20	94119-11	47103-62	420	138	50,64
8001643	50 MRT 50 SM	'11→'20	94119-11	47103-62	420	124	50,89
8001610	50 MRX 50	'03→'04	94119-11	47103-48	420	124	38,26
8001612	50 MRX 50	'05→'08	94119-11	47103-52	420	126	41,09
8001609	50 MRX 50 Castrol	'01→'02	94119-12	47103-48	420	124	38,50
8001610	50 MRX 50 Pro/Top	'04	94119-11	47103-48	420	124	38,26
8001612	50 MRX 50 Pro/Top	'05→'08	94119-11	47103-52	420	126	41,09



KIT AFAM / AFAM KIT

Codice Kit Code	Applicazione Application	Anno Year	Pignone F. Sprocket	Corona R. Sprocket	Passo Pitch	Mg. Nm	€
8001200	50 NKD 50	'04→'10	94119-11	80104-47	420	126	41,93
8001605	50 RR 50 Castrol	'99→'02	94119-12	80103-48	420	124	41,90
8001608	50 RR 50 SM Spike	'99→'02	94119-12	80103-48	420	124	41,90
8001611	50 RRX 50 SM Spike	'03→'04	94119-11	80105-48	420	124	41,65
8001613	50 RRX 50 SM Spike	'05→'08	94119-11	80105-52	420	126	44,91
8001636	50 RRX 50 SM Spike	'06→'09	94119-11	92122-52	420	126	42,95
8001131	50 RS 50 NKD	'13→'17	94119-11	47103-47	420	134	39,35
8001244	50 RS 50 Sport	'12→'17	94119-11	47103-47	420	134	39,35
8001241	50 RS1 50	'97→'04	94109-12	80101-44	420	126	42,07
8001243	50 RS2 50 FR	'09→'10	94119-11	80104-47	420	126	41,93
8001243	50 RS2 50 Matrix	'04→'10	94119-11	80104-47	420	126	41,93
8001242	50 RS2 50 Matrix	'02→'03	94119-13	80104-47	420	128	42,99
8001243	50 RS2 50 NKD	'05	94119-11	80104-47	420	126	41,93
8001243	50 RS2 50 Pro	'06→'10	94119-11	80104-47	420	126	41,93
8001244	50 RS3 50	'11→'16	94119-11	47103-47	420	134	39,35
8001131	50 RS3 50 NKD	'12→'16	94119-11	47103-47	420	134	39,35
8001244	50 RS3 50 Pro	'11→'17	94119-11	47103-47	420	134	39,35
8001639	50 SMX 50	'02	94119-12	47103-48	420	124	38,50
8001640	50 SMX 50	'03→'04	94119-11	47103-48	420	124	38,26
8001641	50 SMX 50	'05→'06	94119-11	47103-52	420	126	41,09
8001637	50 SMX 50 Power Up	'07→'08	94119-11	92122-52	420	126	42,95
8001637	50 SMX 50 Pro Street	'06→'08	94119-11	92122-52	420	126	42,95
8001641	50 SMX 50 Pro Supermotard/Top	'04→'07	94119-11	47103-52	420	126	41,09
8013637	125 125 LC Marathon Pro Supermotard	'09→'15	21208-14	47200-56	428	136	51,88
8013100	125 Naked 125	'06→'10	21200-14	80200-46	428	126	43,19
8013101	125 Naked 125 LC	'13→'15	21208-14	47200-48	428	128	39,63
8013500	125 125 Tango	'06→'15	21207-14	47200-48	428	126	39,55
8013500	125 125 Tango Motard	'08→'09	21207-14	47200-48	428	126	39,55
8013500	125 125 Tango Pro	'07→'10	21207-14	47200-48	428	126	39,55
8013241	125 RS2 125	'06→'10	21200-14	80200-46	428	126	43,19
8013241	125 RS2 125 Pro	'07→'10	21200-14	80200-46	428	126	43,19
8013242	125 RS3 125 Sport	'11→'16	21208-14	47200-48	428	128	39,63
8013636	125 SMX 125	'05→'08	21200-14	47200-48	428	126	39,52
8013501	125 MARATHON 125 ENDURO	'09→'20	21208-14	47200-56	428	136	51,88
8013502	125 MARATHON AC	'09→'11	21207-14	47200-56	428	136	52,05
8013503	125 MARATHON 125 AC	'12→'20	20209-15	47200-48	428	134	40,80
8013638	125 MARATHON AC SM	'09→'11	21207-14	47200-56	428	136	52,05
8013639	125 MARATHON 125 AC SM	'12→'20	20209-15	47200-48	428	134	40,80
8013102	125 CENTURY	'18→'20	37200-13	47203-62	428	142	60,91
ROXON							
12501600	50 50 SM Duel	'06→'07	58102-13	47103-48	420	126	41,09
12501600	50 50 TT Duel	'06→'07	58102-13	47103-48	420	126	41,09
SUZUKI							
1401600	50 AP 50	'75→'78	22100-12	14100-38	420	106	34,59
1401200	50 GT 50	'78→'80	22100-13	14100-46	420	114	40,95
1401202	50 RG 50	'91	22103-12	14100-43	420	116	39,00
1401203	50 RG 50 W D	'83	27100-13	14100-46	420	118	41,44
1401800	50 JR 50	'78→'07	27100-13	14102-28	420	78	28,64
1401606	50 RMX 50	'96→'03	22103-12	14109-50	420	128	45,23
1401100	50 RV 50 VanVan	'79	27100-15	14100-32	420	96	31,65
1401636	50 SMX 50	'01→'03	22103-12	14109-50	420	128	45,23
1401602	50 TS 50 APX ER21	'81→'89	22101-12	14100-48	420	112	40,50
1401605	50 TS 50 ERK T,X	'80→'81	27100-13	14100-46	420	114	40,95
1401601	50 TS 50 KN ER21	'79→'80	27100-12	14100-46	420	114	40,74
1401608	50 TS 50 W	'86	22103-12	14100-46	420	120	42,11
1401603	50 TS 50 X Automatique France	'90→'96	22101-12	14100-51	420	130	45,75
1401609	50 TS 50 XK	'84→'02	22103-12	14100-51	420	124	45,57
1401102	50 TV 50 M,R	'91→'94	22103-12	14100-43	420	116	39,00
1401204	50 ZR 50	'83→'90	27100-12	14100-46	420	114	40,74

KIT AFAM / AFAM KIT



Codice Kit Code	Applicazione Application	Anno Year	Pignone F. Sprocket	Corona R. Sprocket	Passo Pitch	Mg. Nm	€
1401201	50 ZR 50 S automatique France	'81→'88	22101-12	14100-46	420	112	40,50
1401161	50 ZR 50 SL automatique France	'81→'88	22101-12	14100-43	420	110	37,66
1407751	80 DS 80	'80→'00	22102-14	14101-40	428	102	37,42
1407161	80 GT 80 L	'81→'82	22102-14	14101-40	428	110	38,47
1407752	80 JR 80 K1,K2,K3,K4,K5,K6,K7	'01→'07	22102-14	14101-40	428	102	37,42
1407200	80 RG 80	'80→'81	22102-14	14101-43	428	112	39,45
1407241	80 RG 80 Gamma	'84→'93	28200-14	14201-47	428	130	44,74
1407600	80 TS 80 ER	'81→'84	22102-14	14101-46	428	114	42,67
1407601	80 TS 80 X / RH	'84→'88	28200-14	14101-43	428	122	40,75
1413500	125 DR 125 S Z,D,E	'82→'84	22200-14	14200-47	428	122	43,02
1413636	125 DR 125 SM K8,K9,L0,L1,L2,L3	'08→'13	21200-16	14207-50	428	130	46,52
1413161	125 GN 125 E R,S,T	'94→'96	22200-14	14201-41	428	114	39,06
1413162	125 GN 125 E V,W,X,Y,K1	'97→'01	22205-14	14201-41	428	114	40,74
1413162	125 GN 125 V,W,X,Y,K1	'97→'01	22205-14	14201-41	428	114	40,74
1413161	125 GN 125 Z,D,R,S,T	'82→'96	22200-14	14201-41	428	114	39,06
1413301	125 GP 125	'78→'89	33201-15	14201-41	428	124	40,61
1413132	125 GS 125 ES X,Y	'97→'00	22200-14	14201-43	428	124	40,36
1413131	125 GS 125 ES Z,D,F,K,L,M,R	'82→'96	22200-14	14201-43	428	116	39,31
1413131	125 GS 125 Z,D	'82→'84	22200-14	14201-43	428	116	39,31
1413163	125 GZ 125 Marauder W,X,Y,K1,K2,K3, K4,K5,K6,K7,K8,K9,L0,L1	'98→'11	22205-15	14213-45	428	132	45,40
1413302	125 RG 125 BU Gamma J	'88	28200-15	14201-41	428	128	41,80
1413302	125 RG 125 C Gamma G,H,J	'86→'90	28200-15	14201-41	428	128	41,80
1413302	125 RG 125 Gamma J	'88	28200-15	14201-41	428	128	41,80
1413302	125 RG 125 UC G,H,J	'86→'88	28200-15	14201-41	428	128	41,80
1413100	125 RV 125 K,L,M,A	'73→'76	33201-15	14201-50	428	116	44,63
1413101	125 RV 125 Van-Van K2,K3,K4,K5,K6	'02→'06	33201-15	14215-51	428	134	47,99
1413600	125 TS 125 A,B,C,CZ	'75→'78	28200-14	14200-50	428	118	45,33
1413601	125 TS 125 ER N,T,X,Z	'79→'82	28200-15	14200-44	428	114	42,04
1413166	125 TU 125 X	'99	22205-14	14201-41	428	114	40,74
1413164	125 VL 125 Intruder X,Y,K1,K2,K3,K4, K5,K6,K7,K8	'99→'08	22205-14	14214-56	428	142	54,82
1413133	125 GSX-S 125	'17→'20	28201-14	14212-45	428	122	42,78
1413241	125 GSX-R 125	'17→'20	28201-14	14212-45	428	122	42,78
1421100	200 RV 200 Van-Van L6,L7	'16→'17	22305-15	14310-46	520	114	81,84
1426161	250 GN 250 F,G,H,J,K,L,M,N,P,R,S,T,V,W	'85→'98	22401-15	14312-41	520	100	65,70
1426241	250 GSX 250 R L7,L8	'17→'18	22310-14	14405-46	520	116	119,18
1426200	250 GW 250 F Inazuma L5	'15	22310-14	14405-46	520	116	119,18
1426200	250 GW 250 Inazuma L3,L4,L5	'13→'15	22310-14	14405-46	520	116	119,18
1426163	250 GZ 250 Marauder K2,K3,K4,K5, K6,K7,K8	'02→'08	22401-15	14312-41	520	110	67,87
1426163	250 GZ 250 X,Y,K1	'99→'01	22401-15	14312-41	520	110	67,87
1426302	250 RGV 250 J,K,L	'88→'90	27500-15	14303-46	520	114	110,89
1426303	250 RGV 250 M,N,P,R,S,T	'91→'96	27500-14	14206-43	520	114	109,17
1426164	250 TU 250 X Volty S,T,V,W,X,Y	'95→'00	22401-15	14312-41	520	100	65,70
1426162	250 VL 250 Intruder Y,K1,K2,K3,K4, K5,K6,K7	'00→'07	22401-15	14313-43	520	114	72,52
1426551	250 DL 250 V-STROM	'17→'20	22310-14	14405-47	520	116	81,88
1438500	370 SP 370 B,C,N,T	'77→'80	22401-15	14304-42	520	100	62,09
1439300	380 GT 380 J,K,L,M,A,B	'72→'7	22502-14	14400-42	530	104	113,41
1443500	400 DR 400 S T,X,Z	'80→'82	22401-16	14206-44	520	108	71,93
1443161	400 GN 400 T,X	'80→'81	22401-16	14401-37	520	98	62,23
1443200	400 GS 400 B,C	'77→'78	28400-16	14400-45	530	104	119,67
1443204	400 GSF 400 Bandit K,L,M,M,N,N	'89→'92	22404-14	14404-47	525	114	134,09
1443205	400 GSF 400 Bandit P,P,R,R,S,T,V	'93→'97	22404-14	14404-46	525	114	131,04
1443201	400 GSX 400 E T,X,Z	'80→'82	28400-15	14400-44	530	104	116,98



KIT AFAM / AFAM KIT

Codice Kit Code	Applicazione Application	Anno Year	Pignone F. Sprocket	Corona R. Sprocket	Passo Pitch	Mg. Nm	€
1443203	400 GSX 400 E-S Z,D,E,F,G,H	'82→'87	28400-16	14400-45	530	110	123,34
1443209	400 GSX 400 F J,K,L	'88→'90	22404-14	14404-48	525	114	134,09
1443202	400 GSX 400 F X,Z,D,E,F	'81→'85	22403-15	14503-43	530	104	116,98
1443208	400 GSX 400 Impulse R,S,T,X	'94→'99	22404-14	14404-48	525	116	135,53
1443206	400 GSX 400 T D	'83→'83	28400-16	14400-44	530	108	120,33
1443207	400 GSX 400 X Impulse J,K,L,M,N,P	'88→'93	22404-14	14404-46	525	110	128,17
1443241	400 GSX-R 400 R L,M,N,P,R,S	'90→'95	22404-14	14404-44	525	108	125,41
1446200	425 GS 425	'79→'80	28400-16	14400-45	530	104	119,67
1451202	450 GS 450 E T,X	'80→'81	28400-16	14400-45	530	104	119,67
1451200	450 GS 450 E Z,D,E,F,G,H,J	'82→'88	28400-16	14400-45	530	110	123,34
1451161	450 GS 450 L	'80→'87	28400-16	14400-42	530	108	117,22
1459500	500 DR 500 S E,F,G,H,J	'84→'88	22401-15	14401-45	520	106	79,70
1459501	500 DR 500 X,Z,D	'81→'83	22401-15	14401-45	520	108	80,26
1459200	500 GS 500 E K,L,M,N,P	'89→'93	27500-16	14405-39	520	110	75,11
1459201	500 GS 500 E R,S,T,V,W,X,Y	'94→'00	22505-16	14405-39	520	110	79,45
1459204	500 GS 500 ED	'82→'83	28400-14	14503-50	530	108	126,07
1459202	500 GS 500 F K4,K5,K6,K7,K8	'04→'08	22505-16	14405-39	520	110	79,45
1459201	500 GS 500 K1,K2,K3,K4,K5,K6,K7	'01→'07	22505-16	14405-39	520	110	79,45
1459203	500 GS 500 Katana	'80→'83	28400-14	14503-50	530	110	127,26
1459205	500 GSX 500 E / ES	'83→'87	28400-14	14503-50	530	114	129,75
1459300	500 GT 500 A,B	'76→'77	22501-15	14400-33	530	110	108,50
1459302	500 RG 500 Gamma G,H,J,K	'86→'89	28400-16	14500-40	530	106	126,22
1459301	500 T 500	'68→'75	22501-15	14400-33	530	110	108,50
1468200	550 GS 550 D B,C	'77→'78	28400-14	14400-45	530	108	120,82
1468201	550 GS 550 E C,N,T,X,Z	'78→'82	28400-15	14503-50	530	110	127,72
1468203	550 GS 550 ES	'83→'86	28400-14	14902-48	530	112	126,74
1468163	550 GS 550 L	'83→'86	28400-14	14503-46	530	112	123,24
1468161	550 GS 550 L T	'80→'80	28400-15	14503-50	530	110	127,72
1468162	550 GS 550 L X,Z	'81→'82	28400-15	14503-50	530	110	127,72
1468204	550 GS 550 M X,Z	'81→'82	28400-15	14503-50	530	112	128,95
1468202	550 GSX 550 EF E,F,G	'84→'86	28400-14	14503-46	530	112	123,24
1468202	550 GSX 550 ES D,E,H	'83→'87	28400-14	14503-46	530	112	123,24
1470500	600 DR 600 R Dakar G,H,J,K	'86→'89	22503-16	14501-42	520	108	111,16
1470500	600 DR 600 S F,G,H,J,K	'85→'89	22503-16	14501-42	520	108	111,16
1470203	600 GSF 600 Bandit S,T,V,W,X	'95→'99	28400-15	14601-47	530	110	138,26
1470206	600 GSF 600 Bandit Y,K1,K2,K3,K4	'00→'04	28400-15	14601-47	530	112	139,69
1470203	600 GSF 600 S Bandit T,V,W,X	'96→'99	28400-15	14601-47	530	110	138,26
1470206	600 GSF 600 S Bandit Y,K1,K2,K3,K4	'00→'04	28400-15	14601-47	530	112	139,69
1470100	600 GSR 600 K6,K7,K8,K9,L0	'06→'10	28401-16	14604-48	525	114	138,22
1470201	600 GSX 600 F K,L,M	'89→'91	28400-14	14601-46	530	112	135,73
1470207	600 GSX 600 F N,P,R,S,T,V	'92→'97	28400-14	14601-45	530	112	135,73
1470205	600 GSX 600 F W,X,Y,K1,K2,K3,K4,K5,K6	'98→'06	28400-15	14601-47	530	118	144,03
1470243	600 GSX-R 600 K1,K2,K3	'01→'03	28401-16	14604-45	525	110	132,30
1470244	600 GSX-R 600 K4,K5	'04→'05	28401-16	14604-45	525	112	133,74
1470245	600 GSX-R 600 K6,K7,K8,K9,L0	'06→'10	28401-16	14604-43	525	114	133,84
1470246	600 GSX-R 600 L1,L2,L3,L4,L5,L6,L7	'11→'17	28401-16	12815-43	525	114	133,84
1470241	600 GSX-R 600 V	'97→'97	28401-16	14507-45	525	108	127,83
1470242	600 GSX-R 600 W,X,Y	'98→'00	28401-16	14507-46	525	108	127,83
1470202	600 RF 600 R P,R	'93→'94	28400-14	14601-43	530	108	131,04
1470204	600 RF 600 R S,T,V	'95→'97	28400-14	14601-42	530	108	127,93
1473554	650 DL 650 A V-Strom ABS K7,K8,K9, L0,L1,L2,L3,L4,L5,L6,L7	'07→'17	28401-15	14604-47	525	118	140,43
1473554	650 DL 650 A V-Strom Traveller ABS K7GT,K8GT,K9GT,L0GT,L1GT	'07→'11	28401-15	14604-47	525	118	140,43
1473554	650 DL 650 A V-Strom Xpedition ABS L1XP	'11	28401-15	14604-47	525	118	140,43
1473552	650 DL 650 V-Strom K4,K5,K6	'04→'06	28401-15	14604-47	525	116	139,03
1473553	650 DL 650 X V-Strom K7,K8,K9,L0,L1	'07→'11	28401-15	14604-47	525	118	140,43
1473554	650 DL 650 XA V-Strom XT ABS L5,L6,L7	'15→'17	28401-15	14604-47	525	118	140,43

KIT AFAM / AFAM KIT



Codice Kit Code	Applicazione Application	Anno Year	Pignone F. Sprocket	Corona R. Sprocket	Passo Pitch	Mg. Nm	€
1473500	650 DR 650 R L,M,N,P	'90→'93	22503-16	14501-42	520	114	114,87
1473500	650 DR 650 RE R,S	'94→'95	22503-16	14501-42	520	114	114,87
1473500	650 DR 650 RS L,M	'90→'91	22503-16	14501-42	520	114	114,87
1473500	650 DR 650 RSE M,N,P,R,S,T	'91→'96	22503-16	14501-42	520	114	114,87
1473501	650 DR 650 SE T,T,V,V,W,X,Y,K1,K2, K3,K4,K5,K6	'96→'06	22602-15	14506-41	525	110	125,79
1473201	650 GR 650 D,E,F	'83→'85	22403-15	14503-38	530	106	122,19
1473200	650 GS 650 G Katana X,Z,D	'81→'83	28400-15	14503-46	530	108	133,32
1473204	650 GSF 650 N Bandit ABS K5,K6	'05→'06	28400-15	14601-47	530	116	142,60
1473211	650 GSF 650 N Bandit ABS K7,K8,K9, L0,L1,L2,L3,L4,L5	'07→'15	28401-15	14404-48	525	118	137,38
1473203	650 GSF 650 N Bandit K5,K6	'05→'06	28400-15	14601-47	530	112	139,69
1473207	650 GSF 650 N Bandit K7,K8,K9,L0, L1,L2,L3,L4,L5	'07→'15	28401-15	14404-48	525	118	137,38
1473206	650 GSF 650 S Bandit ABS K5,K6	'05→'06	28400-15	14601-47	530	116	142,60
1473208	650 GSF 650 S Bandit ABS K7,K8,K9, L0,L1,L2,L3,L4,L5	'07→'15	28401-15	14404-48	525	118	137,38
1473205	650 GSF 650 S Bandit K5,K6	'05→'06	28400-15	14601-47	530	112	139,69
1473210	650 GSF 650 S Bandit K7,K8,K9,L0, L1,L2,L3	'07→'13	28401-15	14404-48	525	118	137,38
1473209	650 GSX 650 F K8,K9,L0,L1,L2,L3, L4,L5,L6	'08→'16	28401-15	14404-48	525	118	137,38
1473212	650 GSX 650 FA ABS K8,K9,L0,L1,L2, L3,L4,L5,L6	'08→'16	28401-15	14404-48	525	118	137,38
1473101	650 SFV 650 A Gladius ABS K9,L0,L1, L2,L3,L4,L5,L6	'09→'16	27500-15	14405-46	520	112	117,78
1473100	650 SFV 650 Gladius K9,L0,L1,L2,L3, L4,L5,L6	'09→'16	27500-15	14405-46	520	112	117,78
1473141	650 SV 650 A ABS + CAFE RACER + SCRAMBLER	'16→'17	27500-15	14405-46	520	112	117,78
1473131	650 SV 650 N X,Y,K1,K2,K3,K4,K5, K6,K7,K8,K9,L0	'99→'10	28401-15	14404-45	525	110	128,63
1473133	650 SV 650 NA ABS K7,K8,K9,L0	'07→'10	28401-15	14404-45	525	114	131,50
1473135	650 SV 650 S K8,K9,L0,L1	'08→'11	28401-15	14404-45	525	108	127,20
1473132	650 SV 650 S X,Y,K1,K2,K3,K4,K5,K6,K7	'99→'07	28401-15	14404-44	525	108	125,87
1473134	650 SV 650 SA ABS K7,K8,K9,L0,L1,L2,L3	'07→'13	28401-15	14404-45	525	114	131,50
1473141	650 SV 650 XA ABS L8	'18→'18	27500-15	14405-46	520	112	121,14
1473551	650 XF 650 Freewind V,W,X,Y,K1,K2	'97→'02	22602-15	14506-43	525	110	129,89
1477500	750 DR 750 S J	'88→'88	22600-15	14401-48	520	116	124,78
1477501	750 DR 750 S K	'89	22600-15	14501-48	520	116	124,78
1477200	750 GS 750 B	'77	33600-15	14600-41	630	96	211,44
1477200	750 GS 750 D B,C	'77→'78	33600-15	14600-41	630	96	211,44
1477200	750 GS 750 E C,N	'78→'79	33600-15	14600-41	630	96	211,44
1477101	750 GSR 750 A ABS L2,L3,L4,L5,L6,L7	'12→'17	28401-17	14604-42	525	112	128,84
1477100	750 GSR 750 L1,L2,L3,L4,L5,L6	'11→'16	28401-17	14604-42	525	112	128,84
1477201	750 GSX 750 E T,X,Z	'80→'82	22601-15	14600-41	630	96	217,92
1477202	750 GSX 750 EF E,F	'84→'85	28400-14	14503-43	530	114	135,38
1477202	750 GSX 750 ES D,E,G,H,J,K	'83→'89	28400-14	14503-43	530	114	135,38
1477203	750 GSX 750 F K,L,M,N,P,R,S,T,V	'89→'97	28400-15	14601-47	530	118	144,03
1477206	750 GSX 750 F W,X,Y,K1,K2,K3,K4,K5,K6	'98→'06	28400-15	14601-45	530	116	139,10
1477205	750 GSX 750 Inazuma W,X,Y,K1,K2,K3	'98→'03	28400-15	14902-42	530	112	131,25
1477201	750 GSX 750 L	'82→'82	22601-15	14600-41	630	96	217,92
1477202	750 GSX 750 S E	'84	28400-14	14503-43	530	114	135,38
1477202	750 GSX 750 S2 Katana E	'84	28400-14	14503-43	530	114	135,38
1477202	750 GSX 750 SE Katana	'85	28400-14	14503-43	530	114	135,38
1477201	750 GSX 750 T,X	'80→'81	22601-15	14600-41	630	96	217,92
1477241	750 GSX-R 750 F	'85	28400-14	14601-42	530	106	126,50
1477242	750 GSX-R 750 G,H	'86→'87	28400-14	14601-42	530	110	129,37
1477243	750 GSX-R 750 J,K	'88→'89	28400-15	14601-44	530	108	131,50
1477249	750 GSX-R 750 K4,K5	'04→'05	28401-17	14604-43	525	110	131,50
1477250	750 GSX-R 750 K6,K7,K8,K9,L0	'06→'10	28401-17	14604-45	525	116	137,14
1477244	750 GSX-R 750 L,M	'90→'91	28400-15	14902-43	530	108	131,50



KIT AFAM / AFAM KIT

Codice Kit Code	Applicazione Application	Anno Year	Pignone F. Sprocket	Corona R. Sprocket	Passo Pitch	Mg. Nm	€
1477251	750 GSX-R 750 L1,L2,L3,L4,L5,L6,L7	'11→'17	28401-17	12815-45	525	116	137,14
1477241	750 GSX-R 750 R G	'86	28400-14	14601-42	530	106	126,50
1477371	750 GSX-R 750 R J,K	'88→'89	28400-15	14902-39	530	104	123,90
1477372	750 GSX-R 750 R SP N,P,R,S	'92→'95	28400-16	14902-42	530	108	129,26
1477246	750 GSX-R 750 T,V	'96→'97	28400-16	16603-43	530	108	132,37
1477245	750 GSX-R 750 W N,P,R,S	'92→'95	28400-15	14902-42	530	108	128,38
1477247	750 GSX-R 750 W,X	'98→'99	28401-16	14507-44	525	108	126,50
1477248	750 GSX-R 750 Y,K1,K2,K3	'00→'03	28401-17	14604-42	525	110	127,40
1477103	750 GSX-S 750 A ABS L5,L6,L7	'15→'17	28401-17	14604-42	525	112	154,63
1477102	750 GSX-S 750 L5	'15	28401-17	14604-42	525	112	154,63
1477300	750 GT 750 A,B	'76→'77	22502-16	14503-43	530	108	132,37
1480502	800 DR 800 S K,L	'89→'90	22600-15	14501-48	520	116	124,78
1480500	800 DR 800 S M,N,P	'91→'93	22600-15	14501-47	520	116	124,78
1480501	800 DR 800 S R,S,T	'94→'96	22602-15	14603-47	525	116	138,57
1480161	800 VZ 800 Marauder V,W,X,Y,K1,K2, K3,K4	'97→'04	28400-15	14601-48	530	116	142,60
1486200	900 RF 900 R R,S,T,V,W,X	'94→'99	28400-15	14902-43	530	110	132,94
1489553	1000 DL 1000 A V-Strom ABS L4,L5, L6,L7,L8	'14→'8	28401-17	14604-41	525	120	162,16
1489551	1000 DL 1000 V-Strom K2,K3,K4,K5, K6,K7,K8,K9,L0,L1	'02→'11	28401-17	14604-41	525	112	154,63
1489553	1000 DL 1000 XA V-Strom XT ABS L7,L8	'17→'18	28401-17	14604-41	525	120	162,16
1489201	1000 GS 1000 S + GSX KATANA	'79→'82	22601-15	14600-42	630	96	222,54
1489245	1000 GSX-R 1000 + R	'17	22801-17	12815-45	525	120	206,44
1489244	1000 GSX-R 1000 A ABS L5,L6,L7	'15→'17	22900-17	12813-42	530	114	170,56
1489409	1000 GSX-R 1000 A ABS L5,L6,L7	'15→'17	22901-17	12815-42	525	114	189,63
1489242	1000 GSX-R 1000 K1,K2,K3,K4,K5,K6	'01→'06	28400-17	86603-42	530	110	166,50
1489405	1000 GSX-R 1000 K1,K2,K3,K4,K5,K6	'01→'06	28403-17	14604-42	525	110	184,77
1489243	1000 GSX-R 1000 K7,K8	'07→'08	28400-17	86603-43	530	112	171,64
1489407	1000 GSX-R 1000 K7,K8	'07→'08	28403-17	14604-43	525	112	191,35
1489244	1000 GSX-R 1000 K9,L0,L1,L2,L3, L4,L5,L6	'09→'16	22900-17	12813-42	530	114	170,56
1489409	1000 GSX-R 1000 K9,L0,L1,L2,L3, L4,L5,L6	'09→'16	22901-17	12815-42	525	114	189,63
1489244	1000 GSX-R 1000 Z L3	'13	22900-17	12813-42	530	114	170,56
1489133	1000 GSX-S 1000 + ABS	'15→'18	28401-17	12815-44	525	116	194,22
1489134	1000 GSX-S 1000 FA ABS L5,L6,L7,L8	'15→'18	28401-17	12815-44	525	116	194,22
1489132	1000 SV 1000 N K3,K4,K5,K6,K7	'03→'07	28400-17	86603-40	530	110	164,89
1489200	1000 SV 1000 S K3,K4,K5,K6,K7	'03→'07	28400-17	86603-40	530	108	162,86
1489241	1000 TL 1000 R W,X,Y,K1,K2	'98→'02	28400-17	16603-39	530	104	155,68
1489131	1000 TL 1000 S V,W,X,Y,K1	'97→'01	28400-17	16603-38	530	104	152,53
1490551	1050 DL 1050 V-STROM	'20	28401-17	14604-41	525	120	162,16
1492200	1100 GS 1100 E + ES	'80→'83	22601-15	14600-42	630	96	222,54
1492201	1100 GS 1100 ES Z	'82	22601-15	14600-42	630	98	225,27
1492202	1100 GSX 1100 EF E,F	'84→'85	22601-15	14600-42	630	102	230,87
1492201	1100 GSX 1100 ES D	'83	22601-15	14600-42	630	98	225,27
1492202	1100 GSX 1100 ES E	'84	22601-15	14600-42	630	102	230,87
1492203	1100 GSX 1100 F H,J	'87→'88	28400-15	14902-52	530	118	183,89
1492205	1100 GSX 1100 F H,J	'87→'88	22800-15	14901-52	532	118	287,95
1492204	1100 GSX 1100 F K,L,M,N,P,R	'89→'94	28400-15	14902-52	530	122	187,95
1492206	1100 GSX 1100 F K,L,M,N,P,R	'89→'94	22800-15	14901-52	532	122	294,98
1492161	1100 GSX 1100 L	'80	22601-15	14600-41	630	96	217,92
1492241	1100 GSX-R 1100 G,H	'86→'87	28400-14	14601-47	530	114	174,02
1492243	1100 GSX-R 1100 J	'88	28400-14	14601-46	530	114	170,52
1492245	1100 GSX-R 1100 K	'89	28400-15	14902-48	530	114	174,48
1492247	1100 GSX-R 1100 K	'89	22800-15	14901-48	532	114	274,09
1492246	1100 GSX-R 1100 L,M,N	'90→'92	28400-15	14902-48	530	118	178,54
1492248	1100 GSX-R 1100 L,M,N	'90→'92	22800-15	14901-48	532	118	281,13
1492252	1100 GSX-R 1100 W P,R	'93→'94	28400-15	14902-42	530	114	166,04

KIT AFAM / AFAM KIT



Codice Kit Code	Applicazione Application	Anno Year	Pignone F. Sprocket	Corona R. Sprocket	Passo Pitch	Mg. Nm	€
1492250	1100 GSX-R 1100 W P,R	'93→'94	22800-15	14901-42	532	114	263,45
1492253	1100 GSX-R 1100 W S,T,V,W	'95→'98	28400-16	14902-44	530	116	172,06
1492251	1100 GSX-R 1100 W S,T,V,W	'95→'98	22800-16	14901-44	532	116	271,92
1495203	1200 GS 1200 SS K1	'01	28400-15	14902-45	530	114	170,98
1495204	1200 GSF 1200 A Bandit ABS K6	'06	28400-15	86603-45	530	116	176,12
1495204	1200 GSF 1200 N Bandit K6	'06	28400-15	86603-45	530	116	176,12
1495200	1200 GSF 1200 N Bandit T,V,W,X,Y, K1, K2,K3,K4,K5	'96→'05	28400-15	14902-45	530	110	166,92
1495205	1200 GSF 1200 S Bandit K6	'06	28400-15	86603-45	530	116	176,12
1495202	1200 GSF 1200 S Bandit T,V,W,X,Y,K1, K2,K3,K4,K5	'96→'05	28400-15	14902-45	530	110	166,92
1495206	1200 GSF 1200 SA Bandit ABS K6	'06	28400-15	86603-45	530	116	176,12
1495203	1200 GSF 1200 SA Bandit ABS V,W,X, Y,K1,K2,K3,K4,K5	'97→'05	28400-15	14902-45	530	114	170,98
1495201	1200 GSX 1200 FS Inazuma W,X,Y	'98→'00	28400-15	14902-44	530	112	167,13
1496203	1250 GSF 1250 N Bandit ABS K7,K8, K9,L0,L1	'07→'11	28400-18	86603-43	530	118	178,43
1496200	1250 GSF 1250 N Bandit K7,K8,K9, L0,L1,L2	'07→'12	28400-18	86603-43	530	118	178,43
1496201	1250 GSF 1250 S Bandit K7,K8,K9,L0	'07→'10	28400-18	86603-43	530	118	178,43
1496202	1250 GSF 1250 SA Bandit ABS K7,K8, K9,L0,L1,L2,L3,L4,L5,L6	'07→'16	28400-18	86603-43	530	118	178,43
1496204	1250 GSX 1250 FA ABS L0,L1,L2,L3, L4,L5,L6	'10→'16	28400-18	86603-43	530	118	178,43
1496204	1250 GSX 1250 FA ST Traveller ABS L0,L1,L2,L3,L4,L5	'10→'15	28400-18	86603-43	530	118	178,43
1497100	1300 GSX 1340 BK B-King K8,K9,L0,L1,L2	'08→'12	22900-18	86603-43	530	118	229,43
1497241	1300 GSX-R 1300 R Hayabusa X,Y,K1, K2,K3,K4,K5,K6,K7	'99→'07	28400-17	16603-40	530	112	212,24
1497242	1300 GSX-R 1340 R Hayabusa K8,K9, L0,L1,L2	'08→'12	22900-18	86603-43	530	114	223,65
1497243	1300 GSX-R 1340 RA Hayabusa ABS L3,L4,L5,L6,L7	'13→'17	22900-18	86603-43	530	114	223,65
1498200	1400 GSX 1400 K1,K2,K3,K4,K5,K6,K7	'01→'07	28400-18	14911-41	530	116	220,33

SUZUKI CORONE ALLUMINIO + TRASFORMAZIONE #520

1570412	600 GSR 600 K6,K7,K8,K9,L0	'06→'10	28404-16	15605-48	520	114	183,20
1570402	600 GSX-R 600 K1,K2,K3	'01→'03	28404-16	15605-45	520	110	176,27
1570403	600 GSX-R 600 K4,K5	'04→'05	28404-16	15605-45	520	112	178,05
1570404	600 GSX-R 600 K6,K7,K8,K9,L0	'06→'10	28404-16	15605-43	520	114	177,95
1570411	600 GSX-R 600 L1,L2,L3,L4,L5,L6,L7	'11→'17	28404-16	13814-43	520	114	177,95
1570401	600 GSX-R 600 V	'97	28404-16	17404-45	520	108	174,48
1570401	600 GSX-R 600 W,X,Y	'98→'00	28404-16	17404-45	520	108	174,48
1573401	650 SV 650 N X,Y,K1,K2,K3,K4,K5, K6,K7,K8,K9,L0	'99→'10	28404-15	15405-45	520	110	175,53
1573403	650 SV 650 S K8,K9,L0,L1	'08→'11	28404-15	15405-45	520	108	173,74
1573402	650 SV 650 S X,Y,K1,K2,K3,K4,K5,K6,K7	'99→'07	28404-15	15405-44	520	108	171,85
1577413	750 GSR 750 L1,L2,L3,L4,L5,L6	'11→'16	28404-17	15605-42	520	112	173,99
1577408	750 GSX-R 750 J,K	'88→'89	28402-15	15405-44	520	108	172,17
1577405	750 GSX-R 750 K4,K5	'04→'05	28404-17	15605-43	520	110	174,97
1577406	750 GSX-R 750 K6,K7,K8,K9,L0	'06→'10	28404-17	15605-45	520	116	182,25
1577412	750 GSX-R 750 L1,L2,L3,L4,L5,L6,L7	'11→'17	28404-17	13814-45	520	116	182,25
1477104	750 GSX-S 750	'17→'20	28401-17	12815-43	520	114	155,20
1577402	750 GSX-R 750 T,V	'96→'97	28402-16	17404-43	520	108	172,97
1577403	750 GSX-R 750 W,X	'98→'99	28404-16	17404-45	520	108	174,48
1577404	750 GSX-R 750 Y,K1,K2,K3	'00→'03	28404-17	15605-42	520	110	172,21
1589410	1000 GSX-R 1000 A ABS L5,L6,L7	'15→'17	22902-17	13814-42	520	114	208,82



KIT AFAM / AFAM KIT

Codice Kit Code	Applicazione Application	Anno Year	Pignone F. Sprocket	Corona R. Sprocket	Passo Pitch	Mg. Nm	€
1589403	1000 GSX-R 1000 K1,K2,K3,K4,K5,K6	'01→'06	28402-17	15605-42	520	110	202,90
1589408	1000 GSX-R 1000 K7,K8	'07→'08	28402-17	15605-43	520	112	208,01
1589410	1000 GSX-R 1000 K9,L0,L1,L2,L3,L4,L5,L6	'09→'16	22902-17	13814-42	520	114	208,82
1589413	1000 GSX-R 1000 L7	'17	22802-17	13814-45	520	120	223,34
1589413	1000 GSX-R 1000 R L7	'17	22802-17	13814-45	520	120	223,34
1589411	1000 GSX-S 1000 + ABS	'15→'18	28404-17	13814-44	520	116	212,38
1589411	1000 GSX-S 1000 L5,L6,L7,L8	'15→'18	28404-17	13814-44	520	116	212,38
1489413	1000 GSXR 1000 #520 STEEL RAC 2017-2020	'17→'20	22802-17	12814RLK-45	520	120	213,96
1589406	1000 SV 1000 N K3,K4,K5,K6,K7	'03→'07	28402-17	15605-40	520	110	197,23
1589404	1000 SV 1000 S K3,K4,K5,K6,K7	'03→'07	28402-17	15605-40	520	108	194,85
1597401	1300 GSX-R 1300 R Hayabusa X,Y,K1, K2,K3,K4,K5,K6,K7	'99→'07	28402-17	17404-40	520	112	199,57

TRIUMPH

8670242	600 600 Daytona	'03→'04	24506-15	14604-45	525	108	137,17
8670241	600 600 Speedfour	'02→'03	24506-14	86500-42	525	106	129,37
8670243	600 600 Speedfour	'04→'05	24506-15	14604-45	525	108	137,17
8670240	600 TT 600	'00→'03	24506-14	86500-42	525	106	129,37
8674242	675 675 Daytona	'13→'16	28401-15	86605-47	525	114	137,59
8674241	675 675 Daytona	'06→'12	28401-16	86605-47	525	116	139,66
8674242	675 675 R Daytona	'13	28401-15	86605-47	525	114	137,59
8674242	675 675 R Daytona	'14→'17	28401-15	86605-47	525	114	137,59
8674241	675 675 R Daytona	'11→'12	28401-16	86605-47	525	116	139,66
8674200	675 675 R Street Triple	'09→'13	28401-16	86605-47	525	116	139,66
8674201	675 675 R Street Triple	'13→'16	28401-16	86605-47	525	118	141,06
8674201	675 675 RX Street Triple	'15→'16	28401-16	86605-47	525	118	141,06
8674201	675 675 Street Triple	'07→'16	28401-16	86605-47	525	118	141,06
8677200	750 750 Daytona	'91→'93	88800-17	86600-48	530	114	142,56
8677201	750 750 Trident	'91→'98	88800-17	86600-48	530	114	142,56
8678200	765 R + RS + S 765 Street Triple	'17→'19	28401-16	86605-46	525	118	151,24
8680131	800 800 Bonneville	'01→'06	88600-17	86500-43	525	104	138,89
8680132	800 800 Bonneville America	'02→'06	88600-17	86604-42	525	112	141,40
8680161	800 800 Speedmaster	'03→'05	88600-16	86604-42	525	112	140,88
8680200	800 800 Tiger + Tiger ABS	'11→'14	28401-16	86605-50	525	122	159,22
8680551	800 800 XC + a + x Tiger + ABS	'11→'17	28401-16	86605-50	525	124	160,87
8680552	800 800 XR + XRt + XRx Tiger ABS	'14→'19	28401-16	86605-50	525	124	160,87
8680131	800 T 100 Bonneville	'01→'06	88600-17	86500-43	525	104	138,89
8686164	865 900 America	'07→'14	88600-18	86604-42	525	112	141,93
8686165	865 900 America 694350 ->	'15→'17	88802-18	86609-42	520	112	152,08
8686136	865 900 Bonneville	'04→'13	88600-18	86500-43	525	104	139,41
8686136	865 900 Bonneville -> 694351	'14	88600-18	86500-43	525	104	139,41
8686164	865 900 Bonneville Black	'07→'08	88600-18	86604-42	525	112	141,93
8686138	865 900 Bonneville+ new church + spirit + t214	'15→'16	88802-18	86608-43	520	104	145,64
8686164	865 900 LT America ->694349	'14	88600-18	86604-42	525	112	129,37
8686100	865 900 Scrambler	'06→'13	88600-18	86500-43	525	106	129,19
8686100	865 900 Scrambler ->694349	'14	88600-18	86500-43	525	106	129,19
8686101	865 900 Scrambler 694350 ->	'15→'17	88802-18	86608-43	520	112	152,81
8686134	865 900 SE Bonneville	'09→'11	88600-18	86500-43	525	104	127,75
8686136	865 900 SE Bonneville	'12	88600-18	86500-43	525	104	127,75
8686136	865 900 SE Bonneville Steve McQueen	'12	88600-18	86500-43	525	104	127,75
8686163	865 900 Speedmaster	'05→'13	88600-18	86604-42	525	112	129,37
8686163	865 900 Speedmaster -> 694386	'14	88600-18	86604-42	525	112	129,37
8686166	865 900 Speedmaster 694350 ->	'15→'17	88802-18	86609-42	520	112	152,08
8686133	865 900 Thruxton	'04→'13	88600-18	86500-43	525	106	129,19
8686139	865 900 Thruxton + ACE	'15→'16	88802-18	86608-43	520	106	147,46
8686133	865 900 Thruxton ->694349	'14	88600-18	86500-43	525	106	129,19

KIT AFAM / AFAM KIT



Codice Kit Code	Applicazione Application	Anno Year	Pignone F. Sprocket	Corona R. Sprocket	Passo Pitch	Mg. Nm	€
8686134	865 T100 900 Bonneville	'04→'13	88600-18	86500-43	525	104	127,75
8686140	865 T100 900 Bonneville + BLACK 694352 ->	'15→'16	88802-18	86608-43	520	104	145,64
8686136	865 T100 900 Bonneville + BLACK ->694351	'14	88600-18	86500-43	525	104	127,75
8686134	865 T100 900 Bonneville Steve Mc Queen	'13	88600-18	86500-43	525	104	127,75
8686207	885 T 509 Speed Triple	'97→'01	88800-18	86601-43	530	108	133,60
8686142	900 Boneville T100	'18→'20	88803-17	86606-41	520	102	137,06
8686551	900 855 i Tiger	'98	88800-18	86600-48	530	114	143,26
8686552	900 855 i Tiger	'99	88800-18	86600-48	530	116	144,70
8686161	900 885 Adventurer	'96→'97	88800-17	86600-43	530	114	137,24
8686162	900 885 Adventurer	'98→'01	88800-18	86600-43	530	114	137,94
8686210	900 885 Speed Triple	'94→'96	88800-17	86600-43	530	110	134,34
8686135	900 885 Thunderbird	'95→'99	88800-17	86600-43	530	110	134,34
8686132	900 885 Thunderbird	'00→'03	88800-18	86600-43	530	114	137,94
8686131	900 885 Thunderbird Sport	'98→'04	88800-17	86600-43	530	114	137,24
8686551	900 885 Tiger	'92→'98	88800-18	86600-48	530	114	143,26
8686552	900 885 Tiger	'99	88800-18	86600-48	530	116	144,70
8686209	900 900 Daytona	'94→'97	88800-17	86600-43	530	110	134,34
8686213	900 900 Daytona	'93	88800-17	86600-46	530	112	137,59
8686209	900 900 Daytona Super III	'94→'97	88800-17	86600-43	530	110	134,34
8686201	900 900 Sprint	'95→'98	88800-17	86600-43	530	110	134,34
8686200	900 900 Sprint	'93→'94	88800-17	86600-46	530	112	137,59
8686201	900 900 Sprint Executive	'97→'98	88800-17	86600-43	530	110	134,34
8686103	900 900 Street Cup	'17	88803-17	86606-41	520	102	137,06
8686102	900 900 Street Scrambler	'17	88803-17	86606-41	520	102	137,06
8686141	900 900 Street Twin	'16→'17	88803-17	86606-41	520	102	137,06
8686214	900 900 Trident	'92→'98	88800-17	86600-46	530	112	155,79
8686215	900 900 Trophy	'94→'01	88800-17	86600-43	530	110	152,19
8686212	900 900 Trophy	'91→'93	88800-17	86600-46	530	112	155,79
8686137	900 TT 885 Legend	'98→'01	88800-17	86600-43	530	114	155,72
8686214	900 TT 900 Trident	'91	88800-17	86600-46	530	112	155,79
8686240	955 955 i Daytona	'99→'01	88800-18	86601-42	530	106	160,02
8686241	955 955 i Daytona	'01→'03	88800-19	86603-44	530	106	166,88
8686242	955 955 i Daytona	'02→'03	88800-19	86601-42	530	106	160,65
8686243	955 955 i Daytona	'04→'06	88800-18	86601-42	530	106	160,02
8686239	955 955 i Daytona	'98	88800-18	86601-43	530	108	165,17
8686211	955 955 RS Sprint	'03→'04	88800-19	86601-43	530	108	165,80
8686206	955 955 Speed Triple	'02	88800-18	86601-42	530	106	129,05
8686204	955 955 ST Sprint	'99→'00	88800-18	86601-43	530	108	165,17
8686205	955 955 ST Sprint	'01→'04	88800-19	86601-43	530	108	165,80
8686553	955 955 Tiger	'00→'04	88800-18	86600-46	530	114	173,08
8686554	955 955 Tiger	'04→'06	88800-18	86603-46	530	114	176,19
8686552	955 955 Tiger	'99	88800-18	86600-48	530	116	144,70
8686203	955 RS 955 Sprint	'99→'02	88800-19	86603-43	530	108	168,91
8686202	955 T 509 Speed Triple	'99→'01	88800-18	86601-43	530	108	165,17
8686207	955 T 509 Speed Triple	'97→'98	88800-18	86601-43	530	108	133,60
8686239	955 T 595 Daytona	'97→'98	88800-18	86601-43	530	108	165,17
8689201	1000 1000 Daytona	'91→'92	88800-17	86600-48	530	112	173,85
8689200	1000 1000 Trophy	'92	88800-17	86600-46	530	112	170,35
8690203	1050 1050 GT Sprint ABS	'10→'16	88800-19	86601-42	530	116	170,80
8690200	1050 1050 i Sprint ST	'11→'12	88800-19	86601-42	530	106	160,65
8690200	1050 1050 i Sprint ST ABS	'11→'12	88800-19	86601-42	530	106	160,65
8690202	1050 1050 R Speed Triple + S + ABS	'11→'17	88800-18	86601-43	530	108	165,17
8690551	1050 1050 SE Tiger ABS	'10→'13	88800-18	86603-44	530	114	174,37
8690201	10501050 Speed Triple	'05→'10	88800-18	86601-42	530	106	160,02
8690201	1050 1050 Speed Triple ABS	'07→'10	88800-18	86601-42	530	106	160,02
8690200	1050 1050 ST Sprint	'05→'10	88800-19	86601-42	530	106	160,65
8690200	1050 1050 ST Sprint ABS	'05→'10	88800-19	86601-42	530	106	160,65



KIT AFAM / AFAM KIT

Codice Kit Code	Applicazione Application	Anno Year	Pignone F. Sprocket	Corona R. Sprocket	Passo Pitch	Mg. Nm	€
8690551	1050 1050 Tiger	'07→'12	88800-18	86603-44	530	114	174,37
8690552	1050 1050 Tiger Sport ABS	'13→'17	88800-18	86601-45	530	120	179,17
8695100	1200 1200 Bonneville Bobber	'17	88900-17	86605-37	525	108	149,52
8695100	1200 1200 Bonneville Bobber Black	'18	88900-17	86605-37	525	108	149,52
8695241	1200 1200 Daytona	'94→'98	88800-18	86600-43	530	110	167,20
8695242	1200 1200 Daytona	'93	88800-18	86600-45	530	112	171,05
8695102	1200 SCRAMBLER XC + XE	'19→'20	88900-16	86605-44	525	114	162,03
8695201	1200 1200 Trophy	'94→'95	88800-18	86600-44	530	110	167,20
8695202	1200 1200 Trophy	'96→'98	88800-18	86600-42	530	110	164,08
8695203	1200 1200 Trophy	'99→'01	88800-19	86600-40	530	110	163,10
8695200	1200 1200 Trophy	'91→'93	88800-18	86600-45	530	112	171,05
8695132	1200 1200 Truxton	'16→'17	88900-16	86605-42	525	100	145,29
8695132	1200 R 1200 Truxton	'16→'17	88900-16	86605-42	525	100	145,29
8695131	1200 T120 1200 Bonneville	'16→'17	88900-17	86605-37	525	100	141,96
8695131	1200 T120 1200 Bonneville Black	'16→'17	88900-17	86605-37	525	100	141,96
8695161	1200 SPEEDMASTER	'19→'20	88900-17	86605-37	525	108	149,50

TRIUMPH CORONE ALLUMINIO + TRASFORMAZIONE # 520

8774404	675 675 Daytona	'13→'16	28404-15	87606-47	520	114	182,46
8774401	675 675 Daytona	'06→'12	28404-16	87606-47	520	116	185,015
8774404	675 675 R Daytona	'13	28404-15	87606-47	520	114	182,46
8774401	675 675 R Daytona	'11→'12	28404-16	87606-47	520	116	185,015
8774402	675 675 R Street Triple	'09→'13	28404-16	87606-47	520	116	185,015
8774403	675 675 R Street Triple	'13→'16	28404-16	87606-47	520	118	186,795
8774403	675 675 RX Street Triple	'15→'16	28404-16	87606-47	520	118	186,795
8774402	675 675 Street Triple	'07→'13	28404-16	87606-47	520	116	185,015
8774403	675 675 Street Triple	'13→'14	28404-16	87606-47	520	118	186,795
8774403	675 675 Street Triple	'15→'16	28404-16	87606-47	520	118	186,795
8778401	765 R 765 Street Triple	'17	28404-16	87606-46	520	118	183,435
8778401	765 RS 765 Street Triple	'17	28404-16	87606-46	520	118	183,435
8778401	765 S 765 Street Triple	'17	28404-16	87606-46	520	118	183,435

VOXAN

8989100	1000 1000 Black Magic	'06→'08	91800-18	92666-39	525	114	164,325
8989241	1000 1000 Cafe Racer	'99→'08	91800-18	92666-39	525	106	156,735
8989242	1000 1000 Charade Racing	'05→'08	91800-18	92630-40	525	114	164,325
8989131	1000 1000 Roadster	'99→'08	91800-18	92666-40	525	106	156,735
8989200	1000 1000 Street Scrambler	'04→'08	91800-18	92666-42	525	106	158,03

YAMAHA

1201600	50 DT 50 M	'78→'82	27100-12	12100-45	420	106	38,93
1201602	50 DT 50 MX	'86→'87	27100-14	12100-38	420	104	34,69
1201603	50 DT 50 MX	'88	30100-14	12100-38	420	104	33,57
1201601	50 DT 50 MX	'81→'85	27100-15	12100-42	420	106	37,60
1201611	50 DT 50 MX	'83→'95	27100-12	12100-48	420	112	40,50
1201605	50 DT 50 R	'91→'95	30100-13	12100-38	420	116	34,76
1201604	50 DT 50 R	'88→'90	30100-13	12100-45	420	120	39,62
1201606	50 DT 50 R	'89→'97	30100-13	12100-48	420	120	40,43
1201607	50 DT 50 R	'96	27100-10	12100-52	420	124	44,70
1201610	50 DT 50 R	'03→'06	94119-11	47103-50	420	126	39,90
1201608	50 DT 50 R	'97→'02	94109-12	12100-52	420	128	46,10
1201612	50 DT 50 R	'07→'12	94119-11	47103-62	420	134	50,16
1201638	50 DT 50 R Supermotard	'03→'06	94119-11	47103-48	420	126	38,54
1201636	50 DT 50 R Supermotard	'02	94119-12	35103-50	420	128	43,20
1201640	50 DT 50 R Supermotard	'07	94119-11	47103-60	420	132	47,68
1201637	50 DT 50 R Supermotard	'02	94118-13	35107-50	428	128	46,31
1201639	50 DT 50 X Supermotard	'08→'12	94119-11	47103-60	420	132	47,68
1201200	50 FS1 50	'76→'79	27100-12	12101-41	420	110	37,66
1201204	50 FS1E 50	'74→'76	27100-13	12100-42	420	100	36,58
1201204	50 FS1E 50 DX	'77→'79	27100-13	12100-42	420	100	36,58

KIT AFAM / AFAM KIT



Codice Kit Code	Applicazione Application	Anno Year	Pignone F. Sprocket	Corona R. Sprocket	Passo Pitch	Mg. Nm	€
1201101	50 LB 50 Chappy	'75→'79	30100-14	12100-32	420	94	30,17
1201102	50 LB 50 Chappy	'80→'81	30100-15	12101-30	420	94	30,38
1201103	50 LB 50 Chappy	'82→'86	30100-14	12100-32	420	94	30,17
1201104	50 LB 50 Chappy	'87→'94	30100-14	12101-32	420	94	30,17
1201100	50 LC 50 MX Bop	'80→'80	30100-14	12101-36	420	92	32,31
1201206	50 RD 50	'78→'79	27100-13	12100-42	420	100	36,58
1201202	50 RD 50 M	'79→'80	27100-12	12101-48	420	106	39,73
1201205	50 RD 50 MX	'81→'87	27100-12	12101-48	420	112	40,50
1201105	50 RZ 50	'02	30100-13	12101-48	420	106	38,65
1201700	50 TT-R 50 E V,W,X,Y,Z,A,B,D,E,F,F,H,J	'06→'18	30100-13	12101-37	420	80	30,21
1201676	50 TY 50 M	'77→'81	27100-12	12100-45	420	104	38,68
1201243	50 TZR 50	'00→'02	94119-12	12113-47	420	132	42,92
1201244	50 TZR 50	'03→'06	94119-11	12115-47	420	132	38,79
1201245	50 TZR 50	'07→'16	94119-11	12115-60	420	138	47,96
1201242	50 TZR 50 Thunderkid	'97→'00	94109-12	12112-47	420	132	43,62
1201241	50 YSR 50 T	'87	27100-12	12100-45	420	102	38,44
1207602	80 DT 80 LC	'81→'84	28200-12	12204-49	428	118	45,09
1207603	80 DT 80 LC-2	'85→'92	28200-15	12204-51	428	126	47,64
1207600	80 DT 80 MX	'81→'83	27100-12	12100-45	420	108	39,17
1207100	80 LB2 80 Chappy	'80	30100-15	12101-30	420	90	29,86
1207101	80 LB3 80 Bop	'80	30100-15	12101-32	420	92	30,38
1207202	80 RD 80 LC	'82	22101-12	12101-48	420	106	39,73
1207201	80 RD 80 MX	'82	27100-12	12101-41	420	108	37,38
1207161	80 RX 80 SE	'82	27100-13	12101-48	420	110	40,46
1207676	80 TY 80	'80	27100-13	12100-42	420	104	37,10
1207241	80 YSR 80	'87→'90	27100-14	12100-38	420	100	34,17
1211751	100 RT 100	'93→'03	30100-14	12101-48	420	104	38,71
1212100	115 T 115 Crypton	'09	21200-15	12200-36	428	104	33,08
1213600	125 DT 125 E	'74→'79	28200-16	12203-37	428	112	37,38
1213602	125 DT 125 LC	'81→'83	21200-15	12204-49	428	118	44,56
1213603	125 DT 125 LC	'84	21200-16	12204-53	428	126	50,30
1213604	125 DT 125 LC	'85→'88	21200-16	12204-49	428	126	45,99
1213601	125 DT 125 MX	'78→'91	28200-16	12204-49	428	118	45,82
1213610	125 DTR 125	'93→'98	21202-16	12207-57	428	134	48,27
1213609	125 DT 125 X	'05→'06	21202-16	12207-57	428	134	48,27
1213605	125 DT-Z 125 Tenere	'88→'90	26200-16	12204-49	428	124	46,59
1213200	125 MT 125	'15→'16	21208-14	12227-48	428	132	40,99
1213200	125 MT 125 A ABS	'15→'18	21208-14	12227-48	428	132	40,99
1213310	125 MT-09 TRACER 2018-2019	'18→'19	21200-14	12227-52	428	130	41,81
1213201	125 MT-125	'20	21200-14	12227-52	428	130	41,81
1213301	125 RD 125 DX	'75→'77	28200-15	12200-39	428	112	36,75
1213302	125 RD 125 DX	'78→'81	28200-15	12201-39	428	112	38,99
1213303	125 RD 125 LC	'82→'85	21200-16	12202-46	428	118	42,85
1213304	125 RD 125 LC	'86→'89	21200-16	12202-45	428	118	41,94
1213300	125 RD 125 T	'75	28200-15	12200-36	428	110	34,90
1213131	125 RS 125	'75	28200-16	12200-36	428	112	35,35
1213131	125 RS 125 DX	'76→'81	28200-16	12200-36	428	112	35,35
1213161	125 SR 125	'89→'98	21200-14	12202-49	428	120	44,56
1213162	125 SR 125	'99→'03	21200-14	12202-49	428	120	44,56
1213161	125 SR 125 SE	'82→'96	21200-14	12202-49	428	120	44,56
1213165	125 SR 125 SE	'83→'87	21200-14	12204-49	428	120	44,56
1213606	125 DT 125 R	'88	21202-17	12207-55	428	134	48,48
1213607	125 DT 125 R/DTR E	'99→'05	21202-16	12207-57	428	134	48,24
1213608	125 DT 125 R	'89→'92	21202-16	12207-55	428	134	48,03
1213504	125 XTZ 125	'03→'10	21200-14	12204-49	428	124	45,06
1213636	125 TDR 125	'89→'93	21202-16	12207-53	428	132	46,38
1213637	125 TDR 125 R	'94→'03	21202-16	12313-57	428	136	52,89
1213100	125 TW 125	'99→'01	21305-14	12208-50	428	122	44,84
1213101	125 TW 125	'02→'06	21305-14	12208-51	428	126	46,38
1213305	125 TZR 125	'87→'92	21200-16	12202-45	428	130	43,48



KIT AFAM / AFAM KIT

Codice Kit Code	Applicazione Application	Anno Year	Pignone F. Sprocket	Corona R. Sprocket	Passo Pitch	Mg. Nm	€
1213307	125 TZR 125	'93→'95	21202-16	12216-46	428	140	45,89
1213306	125 TZR 125 R	'91→'93	21202-18	12313-47	428	136	46,52
1213308	125 TZR 125 RR	'94→'97	21202-18	12313-51	428	136	49,67
1213639	125 WR 125 X Supermoto	'09→'16	21208-14	12207-53	428	132	45,36
1213500	125 XT 125	'82→'87	21200-14	12208-50	428	118	44,32
1213501	125 XT 125	'88→'91	21200-14	12208-54	428	120	48,86
1213502	125 XT 125 R	'05→'11	21207-14	47200-50	428	128	41,27
1213638	125 XT 125 X	'05→'11	21207-14	47200-48	428	126	39,55
1213163	125 XV 125 Virago	'97→'01	21308-13	12505-47	520	114	74,41
1213164	125 XVS 125 Dragstar	'00→'05	21202-16	12221-59	428	146	56,60
1213166	125 YB 125 SPD	'08	21207-14	12200-43	428	118	36,93
1213133	125 YBR 125 E	'06→'13	21207-14	12200-45	428	118	37,21
1213132	125 YBR 125 ED	'05→'06	21200-14	12200-45	428	118	37,18
1213133	125 YBR 125 ED	'07→'14	21207-14	12200-45	428	118	37,21
1213133	125 YBR 125 EGS	'08→'16	21207-14	12200-45	428	118	37,21
1213166	125 YBR 125 SPD Custom	'08→'16	21207-14	12200-43	428	118	36,93
1213134	125 YS 125	'17	21207-14	12227-43	428	126	40,29
1213309	125 YZF-R 125	'08→'16	21208-14	12227-48	428	132	40,99
1213309	125 YZF-R 125 A ABS	'15→'18	21208-14	12227-48	428	132	40,99
1213102	125 Z 125	'0	21200-14	12200-43	428	120	37,14
1214100	135 T 135 S Crypton X	'06→'08	21208-15	12200-39	428	112	35,84
1214100	135 T 135 SE Crypton X	'06→'08	21208-15	12200-39	428	112	35,84
1214102	135 T 135 Spark	'11→'12	21200-15	12200-39	428	120	36,75
1221100	200 TW 200	'89→'94	21305-14	12203-45	428	120	41,55
1224500	240 XT 240	'84→'85	21301-15	12300-46	520	98	68,85
1226602	250 DT 250 MX	'80→'82	30300-15	12305-46	520	104	69,06
1226300	250 RD 250 DX B	'76→'76	30301-17	12303-39	530	96	108,78
1226301	250 RD 250 DX C,D	'77→'78	30301-16	12303-39	530	96	108,26
1226302	250 RD 250 DX E,F	'79→'80	30301-17	12401-39	530	96	108,78
1226303	250 RD 250 LC	'80→'86	30301-16	12302-41	530	102	113,58
1226164	250 SR 250	'88→'90	21301-14	12300-40	520	102	63,04
1226166	250 SR 250	'91→'95	21301-16	12300-46	520	102	70,25
1226162	250 SR 250 SE	'81→'84	21301-16	12300-45	520	102	70,25
1226636	250 TDR 250	'88→'92	27500-14	12304-45	520	108	69,13
1226100	250 XG 250 Tricker	'04→'07	21311-15	12325-45	428	124	47,78
1226200	250 XS 250 D,E,F	'79→'81	30301-15	12401-41	530	100	111,48
1226201	250 XS 250 S E,F	'79→'82	30301-15	12401-39	530	104	112,25
1226500	250 XT 250	'80→'83	21301-16	12300-46	520	98	69,37
1226163	250 XV 250 S Virago	'95→'15	21301-16	12505-45	520	114	72,87
1226163	250 XV 250 Virago	'89→'94	21301-16	12505-45	520	114	72,87
1226165	250 XVS 250 Dragster	'01→'03	21202-20	12221-59	428	146	60,69
1226202	250 YBR 250	'07→'12	21311-15	12226-44	428	132	47,99
1230131	300 MT-03 320 A MTN 320 ABS	'16→'18	27500-14	12814-43	520	112	113,02
1230241	300 YZF-R3 320 ABS	'15→'18	27500-14	12814-43	520	112	113,02
1235300	350 RD 350	'74→'76	28400-16	12303-39	530	96	108,26
1235302	350 RD 350 LC	'80→'82	30301-16	12303-39	530	102	111,97
1235303	350 RD 350 YPVS + LCF	'83→'92	30300-17	12304-39	520	106	102,98
1235304	350 RZ 350	'84→'85	30300-17	12304-39	520	106	102,98
1236200	360 XS 360 B,C	'75→'77	30301-16	12401-39	530	98	109,52
1243600	400 DT 400 MX	'77→'78	30300-17	12500-43	520	102	69,73
1243301	400 RD 400 DX C,D,E,F	'76→'79	30301-17	12401-36	530	96	104,27
1243133	400 SR 400	'14→'16	28404-15	12500-44	520	104	107,56
1243203	400 XJ 400	'82	21501-16	12403-44	530	102	119,88
1243200	400 XS 400 C	'78→'80	30301-16	12401-39	530	104	113,13
1243202	400 XS 400 DOHC	'82→'86	21501-16	12402-38	530	102	112,00
1243161	400 XS 400 SE	'80→'81	30301-16	12401-36	530	106	109,87

KIT AFAM / AFAM KIT



Codice Kit Code	Applicazione Application	Anno Year	Pignone F. Sprocket	Corona R. Sprocket	Passo Pitch	Mg. Nm	€
1243501	400 XT 400 4 Valve	'82→'84	21502-15	12505-45	520	100	71,09
1259241	500 FZR 500	'89→'93	28400-14	12601-46	530	104	118,34
1259133	500 SR 500	'91→'00	28404-16	12500-44	520	104	112,91
1259131	500 SR 500	'78→'90	28400-16	12503-42	530	102	124,92
1259200	500 XS 500 C,D	'78→'79	28400-17	12401-43	530	106	131,47
1259501	500 XT 500	'76→'89	21500-16	12501-42	530	100	112,78
1259500	500 XT 500	'76→'89	27500-16	12502-42	520	100	98,29
1268200	550 XJ 550	'81→'84	21501-16	12403-45	530	104	134,51
1268500	550 XT 550	'82→'83	21502-15	12505-39	520	98	97,72
1270204	600 FZ 6 N	'04→'07	21602-16	12813-46	530	118	147,53
1270205	600 FZ 6 S Fazer	'04→'07	21602-16	12813-46	530	118	147,53
1270205	600 FZ 6 S Fazer ABS	'06→'07	21602-16	12813-46	530	118	147,53
1270209	600 FZ 6 S2	'07→'10	21602-16	12813-46	530	118	147,53
1270210	600 FZ 6 S2 Fazer	'07→'09	21602-16	12813-46	530	118	147,53
1270210	600 FZ 6 S2 Fazer ABS	'08	21602-16	12813-46	530	118	147,53
1270210	600 FZ 6 S2 Fazer ABS	'09	21602-16	12813-46	530	118	147,53
1270242	600 FZR 600 B,D,E	'91→'93	28400-15	12601-45	530	106	131,89
1270243	600 FZR 600 R	'94→'95	28400-15	12801-47	530	108	139,93
1270241	600 FZR 600 W,A	'89→'90	28400-15	12601-46	530	106	131,89
1270203	600 FZS 600 Fazer	'98→'03	28400-15	12801-48	530	110	141,37
1270131	600 SRX 600	'85→'93	21502-15	12304-37	520	104	104,30
1270212	600 XJ 6 F Diversion	'10→'16	21512-16	12604-46	520	118	125,62
1270213	600 XJ 6 FA Diversion ABS	'10→'16	21512-16	12604-46	520	118	125,62
1270132	600 XJ 6 N Diversion	'09→'16	21512-16	12604-46	520	118	125,62
1270133	600 XJ 6 NA Diversion ABS	'09→'16	21512-16	12604-46	520	118	125,62
1270208	600 XJ 6 S Diversion	'09→'16	21512-16	12604-46	520	118	125,62
1270211	600 XJ 6 SA Diversion ABS	'09→'16	21512-16	12604-46	520	118	125,62
1270211	600 XJ 6 SP Diversion ABS	'13	21512-16	12604-46	520	118	125,62
1270202	600 XJ 600 N Diversion	'91→'03	21506-16	12305-48	520	110	127,97
1270200	600 XJ 600 Radian	'84→'91	21501-16	12507-44	530	106	134,13
1270206	600 XJ 600 S Diversion	'92→'03	21506-16	12305-48	520	110	127,97
1270500	600 XT 600	'84→'86	21502-15	12505-40	520	102	105,67
1270502	600 XT 600	'87→'95	21504-15	12505-39	520	102	111,69
1270503	600 XT 600 E	'90→'03	21504-15	12505-45	520	106	120,37
1270551	600 XT 600 Z Tenere	'83→'84	21502-15	12505-39	520	102	105,67
1270553	600 XT 600 Z Tenere	'85	21502-15	12505-40	520	102	105,67
1270555	600 XT 600 Z Tenere	'86→'87	21502-15	12505-40	520	104	106,89
1270557	600 XT 600 Z Tenere	'87→'89	21504-15	12505-40	520	104	112,91
1270558	600 XT 600 Z Tenere	'90→'95	21504-15	12505-45	520	106	120,37
1270200	600 YX 600 Radian	'86→'90	21501-16	12507-44	530	106	134,13
1270244	600 YZF 600 R Thunder cat	'96→'03	28400-15	12801-47	530	108	139,93
1270248	600 YZF 600 R6	'06→'18	21606-16	12815-45	525	114	139,51
1270245	600 YZF 600 R6	'99→'02	21602-16	12607-48	530	116	146,48
1270246	600 YZF 600 R6	'03→'05	21602-16	12813-48	530	116	149,60
1270247	600 YZF 600 R6	'99→'02	21802-16	12608-48	532	116	282,17
1270405	600 YZF 600 R6 #520 steel	'06→'20	21511-16	12814RLK-45	520	114	173,22
1273200	650 XS 650 SE	'79→'81	21600-17	12600-33	530	104	117,88
1273132	660 MT-03 660	'06→'13	21510-15	12305-47	520	112	122,33
1273131	660 SZR 660	'96→'98	21504-15	12304-39	520	110	116,59
1273500	660 XT 660 R	'04→'16	21510-15	12305-45	520	110	118,31
1273636	660 XT 660 X Supermoto	'04→'16	21510-15	12305-45	520	110	118,31
1273553	660 XT 660 Z Tenere	'08→'16	21510-15	12305-45	520	110	118,31
1273554	660 XT 660 ZA Tenere ABS	'11→'16	21510-15	12305-45	520	110	118,31
1273551	660 XTZ 660 Tenere	'90→'95	21504-15	12505-45	520	110	122,82
1273552	660 XTZ 660 Tenere	'96→'00	21504-15	12505-46	520	110	122,82
1275200	700 FZ 700 S	'86	21602-16	12601-46	530	112	140,07
1275161	700 FZX 700 Fazer S,T	'86→'87	21602-16	12601-44	530	108	135,38
1275131	700 MT-07 700	'14→'16	21607-16	12815-43	525	108	158,76
1275133	700 MT-07 700 A ABS	'14→'17	21607-16	12815-43	525	108	158,76



KIT AFAM / AFAM KIT

Codice Kit Code	Applicazione Application	Anno Year	Pignone F. Sprocket	Corona R. Sprocket	Passo Pitch	Mg. Nm	€
1275133	700 MT-07 700 A-U ABS	'18→'20	21607-16	12815-43	525	108	158,76
1275201	700 MTT 700 A-U Tracer	'16→'18	21607-16	12815-43	525	114	164,43
1275202	700 TRACER 700	'20	21607-16	12815-45	525	116	167,64
1275100	700 XSR 700 MTM 690 U	'16→'20	21607-16	12815-43	525	108	158,76
1275551	700 TENERE 700	'20	21607-15	12815-46	525	122	172,25
1277201	750 FZ 750	'85→'86	21602-16	12601-44	530	110	136,82
1277202	750 FZ 750	'87→'89	21602-16	12601-43	530	110	136,82
1277205	750 FZ 750	'90→'91	21602-17	12601-43	530	110	137,52
1277241	750 FZR 750 Genesis	'87→'89	21602-17	12801-42	530	108	136,08
1277242	750 FZR 750 R OW01	'88→'90	21602-16	12801-46	530	108	140,32
1277161	750 FZX 750 Fazer	'86→'91	21602-17	12601-39	530	106	129,93
1277162	750 FZX 750 Fazer	'92→'97	21602-17	12601-38	530	106	126,78
1277551	750 XTZ 750 Super Tenere	'89→'00	21601-16	12305-46	520	112	118,31
1277203	750 YZF 750 R	'93→'98	21602-16	12801-43	530	106	137,07
1277204	750 YZF 750 R	'93→'98	21802-16	12802-43	532	106	257,85
1277243	750 YZF 750 R7 OW02	'99→'03	21602-17	12813-43	530	118	146,41
1277371	750 YZF 750 SP	'93→'99	21602-16	12801-39	530	104	130,90
1280131	800 FZ 8 N S	'10→'16	21607-16	12606-46	525	122	155,86
1280132	800 FZ 8 NA ABS SA ABS	'10→'16	21607-16	12606-46	525	122	155,86
1280200	800 FZ 8 S Fazer	'10→'16	21607-16	12606-46	525	122	155,86
1280201	800 FZ 8 SA Fazer ABS	'10→'16	21607-16	12606-46	525	122	155,86
1283636	850 TDM 850	'91→'95	28401-16	12603-44	525	114	143,58
1283637	850 TDM 850	'96→'98	21606-17	12603-42	525	114	144,52
1283638	850 TDM 850	'99→'01	28401-16	12603-43	525	114	143,58
1283131	850 TRX 850	'96→'99	21606-17	12606-39	525	110	139,94
1283101	850 XSR 900	'16→'20	21607-16	12815-45	525	110	161,98
1283101	850 XSR 900 Abarth	'17→'18	21607-16	12815-45	525	110	161,98
1283132	900 MT-09 850	'13→'20	21607-16	12815-45	525	110	161,98
1283134	900 MT-09 850 A ABS	'14→'20	21607-16	12815-45	525	110	161,98
1283134	900 MT-09 850 A SP ABS	'18	21607-16	12815-45	525	110	161,98
1283134	900 MT-09 850 A Sport Tracker ABS	'14→'17	21607-16	12815-45	525	110	161,98
1283134	900 MT-09 850 A Street Rally ABS	'14→'17	21607-16	12815-45	525	110	161,98
1283134	900 MT-09 850 A Tracer ABS	'15→'18	21607-16	12815-45	525	110	161,98
1283200	900 MT-09 TRACER 2018-2020	'18→'20	21607-16	12815-45	525	118	169,51
1286636	900 TDM 900	'02→'14	21607-16	12606-42	525	118	161,04
1286637	900 TDM 900 A ABS	'05→'13	21607-16	12606-42	525	118	161,04
1283101	900 XSR 850 MTM 850 ABS	'16→'18	21607-16	12815-45	525	110	161,98
1289131	1000 FZ 1 N	'06→'15	21801-17	12813-45	530	122	186,80
1289132	1000 FZ 1 NA Fazer ABS	'08→'15	21801-17	12813-45	530	122	186,80
1289203	1000 FZ 1 S Fazer	'06→'15	21801-17	12813-45	530	122	186,80
1289204	1000 FZ 1 SA Fazer ABS	'08→'15	21801-17	12813-45	530	122	186,80
1289243	1000 FZR 1000 EXUP	'89→'97	21602-17	12801-47	530	110	177,76
1289244	1000 FZR 1000 EXUP	'89→'97	21802-17	12802-47	532	110	272,44
1289241	1000 FZR 1000 Genesis	'87→'88	21602-16	12801-46	530	110	173,56
1289242	1000 FZR 1000 Genesis	'87→'88	21802-16	12802-46	532	110	267,19
1289202	1000 FZS 1000 Fazer N,P,R,S,T,V	'01→'06	21801-16	12813-44	530	116	178,19
1289200	1000 GTS 1000	'93→'99	21602-17	12801-47	530	118	186,24
1289201	1000 GTS 1000	'93→'99	21802-17	12802-47	532	118	286,55
1289133	1000 MT-10 1000	'16→'20	21607-16	12815-43	525	114	195,58
1289133	1000 MT-10 1000 SP	'17→'18	21607-16	12815-43	525	114	195,58
1289133	1000 MT-10 1000 Tourer Edition	'18	21607-16	12815-43	525	114	195,58
1289245	1000 YZF 1000 R Thunderace	'96→'97	21602-17	12801-46	530	110	174,62
1289248	1000 YZF 1000 R Thunderace	'98→'01	21602-17	12801-47	530	110	178,12
1289246	1000 YZF 1000 R Thunderace	'96→'97	21802-17	12802-46	532	110	268,03
1289249	1000 YZF 1000 R Thunderace	'98→'01	21802-17	12802-47	532	110	272,44
1289247	1000 YZF 1000 R1	'98→'03	21801-16	12813-43	530	114	176,16
1289250	1000 YZF 1000 R1	'04→'05	21801-17	12813-45	530	116	180,71
1289251	1000 YZF 1000 R1	'06→'08	21801-17	12813-45	530	118	182,74



KIT AFAM / AFAM KIT

Codice Kit Code	Applicazione Application	Anno Year	Pignone F. Sprocket	Corona R. Sprocket	Passo Pitch	Mg. Nm	€
1289252	1000 YZF 1000 R1	'09→'14	21801-17	12813-47	530	120	188,27
1289402	1000 YZF 1000 R1	'98→'03	21805-16	12815-43	525	114	195,58
1289403	1000 YZF 1000 R1	'04→'05	21805-17	12815-45	525	116	200,06
1289405	1000 YZF 1000 R1	'06→'08	21805-17	12815-45	525	118	202,51
1289409	1000 YZF 1000 R1	'09→'14	21805-17	12815-47	525	120	207,98
1289371	1000 YZF 1000 R1 SP	'06	21801-17	92631-45	530	118	179,62
1289407	1000 YZF 1000 R1 SP	'06	21805-17	92630-45	525	118	199,47
1289253	1000 YZF-R1 1000	'15→'18	21607-16	12816-41	525	114	191,49
1289253	1000 YZF-R1 1000 M	'15→'20	21607-16	12816-41	525	114	191,49
1289411	1000 YZF-R1/ M # 520 RACING 15-20	'15→'20	21611-16	12817RLK-41	520	114	199,05
1292200	1100 FJ 1100	'84→'85	21801-17	12801-41	530	110	137,52
1295200	1200 FJ 1200	'86→'95	21801-17	12801-40	530	110	135,91
1295201	1200 FJ 1200 A ABS	'91→'95	21801-17	12801-39	530	110	135,91
1295202	1200 XJR 1200	'95→'98	21801-17	12801-38	530	110	132,80
1295203	1200 XJR 1200	'95→'98	21803-17	12802-38	532	110	255,85
1297204	1300 XJR 1300 C	'15→'17	21801-17	12813-38	530	110	164,96
1297204	1300 XJR 1300 C Racer	'16→'17	21801-17	12813-38	530	110	164,96
1297200	1300 XJR 1300 L,M,N	'98→'01	21801-17	12801-38	530	110	164,96
1297201	1300 XJR 1300 P,R	'02→'03	21801-18	12801-39	530	112	170,91
1297202	1300 XJR 1300 S,T,V,W	'04→'07	21801-18	12813-39	530	112	170,91
1297200	1300 XJR 1300 SP L,M,N	'99→'01	21801-17	12801-38	530	110	164,96
1297203	1300 XJR 1300 X,Y,Z,A,B,D,E	'08→'14	21801-17	12813-38	530	110	164,96
1299100	1670 MT-01 1670	'05→'12	21801-17	12813-39	530	114	221,41
1299100	1670 MT-01 1670 S	'09	21801-17	12813-39	530	114	221,41
YAMAHA CORONE ALLUMINIO + TRASFORMAZIONE # 520							
1330241	300 YZF-R3 320 ABS	'15→'18	27500-14	13814-43	520	112	134,83
1370403	600 FZS 600 FAZER #520	'98→'02	28402-15	13604-48	520	110	179,20
1370406	600 FZ 6 N	'04→'07	21603-16	13814-46	520	118	187,08
1370408	600 FZ 6 S Fazer	'04→'07	21603-16	13814-46	520	118	187,08
1370408	600 FZ 6 S Fazer ABS	'06→'07	21603-16	13814-46	520	118	187,08
1370409	600 FZ 6 S2	'07→'10	21603-16	13814-46	520	118	187,08
1370410	600 FZ 6 S2 Fazer	'07→'09	21603-16	13814-46	520	118	187,08
1370410	600 FZ 6 S2 Fazer ABS	'08	21603-16	13814-46	520	118	187,08
1370409	600 FZ 6 S2 Fazer ABS	'09	21603-16	13814-46	520	118	187,08
1370405	600 YZF 600 R6	'06→'18	21511-16	13814-45	520	114	182,60
1370402	600 YZF 600 R6	'99→'02	21603-16	11509-48	520	116	187,78
1370404	600 YZF 600 R6	'03→'05	21603-16	13814-48	520	116	187,78
1375401	700 MT-07 700	'14→'16	21611-16	13814-43	520	108	175,35
1375401	700 MT-07 700 A ABS	'14→'17	21611-16	13814-43	520	108	175,35
1375401	700 MT-07 700 A-U ABS	'18	21611-16	13814-43	520	108	175,35
1377402	750 YZF 750 R7 OW02	'99→'03	21603-17	13814-43	520	118	185,01
1380401	800 FZ 8 N	'10→'16	21611-16	13604-46	520	122	189,77
1380401	800 FZ 8 NA ABS	'10→'16	21611-16	13604-46	520	122	189,77
1380401	800 FZ 8 S Fazer	'10→'16	21611-16	13604-46	520	122	189,77
1380401	800 FZ 8 SA Fazer ABS	'10→'16	21611-16	13604-46	520	122	189,77
1383401	900 MT-09 850	'13→'16	21611-16	13814-45	520	110	209,41
1389412	1000 MT-10 1000	'16→'18	21611-16	13814-43	520	114	212,21
1389412	1000 MT-10 1000 SP	'17→'18	21611-16	13814-43	520	114	212,21
1389412	1000 MT-10 1000 Tourer Edition	'18	21611-16	13814-43	520	114	212,21
1389401	1000 YZF 1000 R1	'98→'03	21804-16	13814-43	520	114	212,21
1389403	1000 YZF 1000 R1	'04→'05	21804-17	13814-45	520	116	217,14
1389406	1000 YZF 1000 R1	'06→'08	21804-17	13814-45	520	118	219,49
1389410	1000 YZF 1000 R1	'09→'14	21804-17	13814-47	520	120	225,19
1389408	1000 YZF 1000 R1 SP	'06	21804-17	93622-45	520	118	219,49
1389411	1000 YZF-R1 1000	'15→'18	21611-16	13817-41	520	114	206,65
1389411	1000 YZF-R1 1000 M	'15→'17	21611-16	13817-41	520	114	206,65
1389413	1000 YZF-R1 S 1000	'16	21611-16	13814-41	520	114	207,80

RUOTE
RUOTE



marchesini 

 **motorquality**
TECHNOLOGY FOR SPORT

RUOTE / WHEELS

Identificativo <i>Identity</i>	Modello <i>Model</i>	Materiale <i>Material</i>	Applicazione <i>Application</i>	€
TA	10 SPOKE M10RS KOMPE 300 cc. Bikes	Alluminio Forgiato <i>Forged Aluminium</i>	anteriore/front	575,00
			posteriore bibraccio (cush incluso) <i>rear dual side (cush included)</i>	939,00
TA	10 SPOKE M10RS KOMPE Street Version	Alluminio Forgiato <i>Forged Aluminium</i>	anteriore/front	693,00
			posteriore bibraccio (cush incluso) <i>rear dual side (cush included)</i>	1142,00
			anteriore/front	693,00
			posteriore (monobraccio) <i>rear single side</i>	927,00
TA*	10 SPOKE M10RS KOMPE Street Version - BMW GS 1200	Alluminio Forgiato <i>Forged Aluminium</i>	anteriore/front	840,00
			posteriore/rear	758,00
SM	10 SPOKE M10RR KOMPE MOTARD Spermoto version	Alluminio Forgiato <i>Forged Aluminium</i>	anteriore/front	808,00
			posteriore (bibraccio) <i>rear dual side</i>	1084,00
FM	10 SPOKE M10RS CORSE Street Version	Magnesio Forgiato <i>Forged Magnesium</i>	anteriore/front	1363,00
			posteriore bibraccio (cush incluso) <i>rear dual side (cush included)</i>	1720,00
			anteriore/front	1363,00
			posteriore (monobraccio) <i>rear single side</i>	1384,00
AS	7 SPOKE M7RS GENESI Street Version	Alluminio Forgiato <i>Forged Aluminium</i>	anteriore/front	860,00
			posteriore (bibraccio)	1376,00
			anteriore/front	860,00
			posteriore (monobraccio)	1040,00
FS	7 SPOKE M7R GENESI Street Version	Magnesio Forgiato <i>Forged Magnesium</i>	anteriore/front	1499,00
			posteriore (bibraccio)	1899,00
			rear dual side	
TA	10 SPOKE M10RS KOMPE Racing Version MOTO3	Alluminio Forgiato <i>Forged Aluminium</i>	anteriore/front	636,00
			posteriore bibraccio (cush incluso)	883,00
			rear dual side (cush included)	
F	10 SPOKE M10RS CORSE Racing Version MOTO3	Magnesio Forgiato <i>Forged Magnesium</i>	anteriore/front	1309,00
			posteriore bibraccio (cush incluso)	1806,00
			rear dual side (cush included)	

* : Verniciatura (nero lucido e argento) e versione anodizzata (nero e silver) hanno lo stesso prezzo.

* : Painted (NL and AGN) and anodized versions (AN and ASL) will have the same price.



RICAMBI GOMMINI PARASTRAPPI CUSH DRIVE RUBBERS



Code 4240

Code 4162

Code 4181

PER RUOTE A CATALOGO / FOR CURRENT WHEELS

Modello Model	Tipo Type	Materiale Material	Codice Code	Quantità Quantity	€	
M10RS KOMPE	TA...	10 razze	ALU	4181	5	9,52
M10RR KOMPE Motard	SM...	10 razze	ALU	4154	5	9,52
M7RS GENESI	AS...	7 razze	ALU	4240	5	9,52
M10RS KOMPE Moto3	TA...	10 razze	ALU	4240	3	9,52
M10RS CORSE	FM...	10 razze	MAG	4181	5	9,52
M7R GENESI	FS...	7 razze	MAG	4240	5	9,52
M10RS CORSE Moto3	F...	10 razze	MAG	4240	3	9,52

PER RUOTE FUORI PRODUZIONE / FOR OUT OF PRODUCTION WHEELS

Modello Model	Tipo Type	Materiale Material	Codice Code	Quantità Quantity	€	
M10R KOMPE	TA...	10 razze	ALU	4181	5	9,56
M10RR KOMPE RACING	TA...	10 razze	ALU	4181	5	9,56
M10R CORSE SBK DESIGN	F7...	10 razze	MAG	4181	5	9,56
M10RR CORSE SBK DESIGN	F6...	10 razze	MAG	4181	5	9,56
MAGNESIO FUSO	-	5 razze	MAG	4162	5	9,56

VALVOLE "DE LUXE" A 90° 90° "DE LUXE" VALVES



KIT VALVOLA	-	-	-	KITV90AN	1	25,00
-------------	---	---	---	-----------------	---	-------

- Logo Marchesini "laserato" sul corpo valvola.
- Logo Marchesini sul cappuccio valvola.
- Finitura di anodizzazione nera.

- Marchesini logo lasered on valve body.
- Marchesini logo on valve cap.
- Black anodizing.

Il kit contiene 2 valvole ed il manuale di montaggio.

Kit includes 2 valves and user manual.



TA - 300 cc. BIKES . M10RS KOMPE - ALLUMINIO FORGIATO TA - 300 cc. BIKES . M10RS KOMPE - FORGED ALUMINIUM

Applicazioni Application	Anno Year	Anteriore Front Wheel	Dim. Originale Original Size	Posteriore Rear Wheel	Dim. Originale Original Size
HONDA					
CBR250R ABS	'13→'16	TA71561	17" x 3,00"	TA72688	17" x 4,25"
KAWASAKI					
Ninja 300 ABS	'13→	TA71558	17" x 3,00"	TA72685	17" x 4,25"
KTM					
125 Duke ABS	'13→	TA71559	17" x 3,00"	TA72686	17" x 4,25"
390 Duke ABS	'13→'16	TA71559	17" x 3,00"	TA72686	17" x 4,25"
390 Duke ABS	'17→	TA71588	17" x 3,00"	TA72686	17" x 4,25"
YAMAHA					
MT 03	'16→	TA71560	17x3,00	TA72687	17" x 4,25"
YZF-R3 ABS	'15→	TA71560	17x3,00	TA72687	17" x 4,25"

Queste ruote utilizzano la corona originale.

These wheels use the original sprocket supplied with the bike.

TA - M10RS KOMPE - ALLUMINIO FORGIATO TA - M10RS KOMPE - FORGED ALUMINIUM

Applicazioni Application	Anno Year	Anteriore Front Wheel	Dim. Originale Original Size	Posteriore Rear Wheel	Dim. Originale Original Size
BMW					
* GS1200 R - Adventure	→'12	TA91465 # See Note	19" x 2,50"	TA72599	17" x 4,00"
DUCATI					
* Monster 1100 S	'09→	TA71246	17" x 3,50"	MA72164	17" x 5,50"
* Monster 1100	'09→	TA71246	17" x 3,50"	MA72164	17" x 5,50"
Monster 696	'08→	TA71150	17" x 3,50"	TA72317xx/450	17" x 4,50"
Monster 795	'12→	TA71150	17" x 3,50"	TA72317xx/450	17" x 4,50"
Monster 795 rear oversize	'12→	TA71150	17" x 3,50"	TA72317	17" x 5,50"
* Monster 796 / Hypermotard 796	'10→	TA71246	17" x 3,50"	MA72164	17" x 5,50"
Monster 821	'15→	TA71246	17" x 3,50"	TA72667	17" x 5,50"
* Monster S4R	'03→'06	TA71150	17" x 3,50"	MA72164	17" x 5,50"
* Monster S2R 800	'05→'09	TA71150	17" x 3,50"	MA72164	17" x 5,50"
* Monster S2R 1000	'06→'08	TA71150	17" x 3,50"	MA72164	17" x 5,50"
* Monster S4R Testastretta	'07→'08	TA71246	17" x 3,50"	MA72164	17" x 5,50"
* Monster S4RS Testastretta	'06→'08	TA71246	17" x 3,50"	MA72164	17" x 5,50"
* Monster 1200	2014→	TA71246	17" x 3,50"	MA72481	17" x 6,00"
* Monster 1200 S	2014→	TA71246	17" x 3,50"	MA72481	17" x 6,00"
* Supersport 937	2017→	TA71246	17" x 3,50"	MA72481	17" x 6,00"
* 748/916/996/998	ALL	TA71150	17" x 3,50"	MA72164	17" x 5,50"
* 748/916/996/998	ALL	TA71150	17" x 3,50"	MA72164xx/600	17" x 6,00"
749/749S/999/999S/999R	ALL	TA71246	17" x 3,50"	TA72354	17" x 5,50"
* Multistrada 950	'17→	TA71246	17" x 3,50"	MA72481	17" x 6,00"
* Multistrada 1000 kit	'02→'06	TA71150 • See Note	17" x 3,50"	MA72164	17" x 5,50"
* Multistrada 1100 kit	'07→'08	TA71150 • See Note	17" x 3,50"	MA72164	17" x 5,50"
* Multistrada 1200 (all versions)	'10→	TA71246	17" x 3,50"	MA72481	17" x 6,00"
* 1260 Multistrada	'18→	TA71246	17" x 3,50"	MA72481	17" x 6,00"
* 1260 S Multistrada	'18→	TA71246	17" x 3,50"	MA72481	17" x 6,00"
* Hypermotard 796	'10→'11	TA71246	17" x 3,50"	MA72164	17" x 5,50"
* Hypermotard 821	'13→	TA71246	17" x 3,50"	MA72164	17" x 5,50"
* Hypermotard 939	'16→	TA71246	17" x 3,50"	MA72164	17" x 5,50"
* Hypermotard SP 821	'13→	TA71246	17" x 3,50"	MA72164	17" x 5,50"
* Hyperstrada 821	'13→	TA71246	17" x 3,50"	MA72164	17" x 5,50"
* Hyperstrada 939	'16→	TA71246	17" x 3,50"	MA72164	17" x 5,50"
* Hypermotard/848	'08→	TA71246	17" x 3,50"	MA72164	17" x 5,50"

TA - M10R KOMPE - ALLUMINIO FORGIATO

TA - M10R KOMPE - FORGED ALUMINIUM



Applicazioni Application	Anno Year	Anteriore Front Wheel	Dim. Originale Original Size	Posteriore Rear Wheel	Dim. Originale Original Size
899 Panigale	'13→	TA71487	17" x 3,50"	TA72667	17" x 5,50"
937 Supersport	'17→	TA71246	17" x 3,50"	MA72164	17" x 5,50"
959 Panigale	'16→	TA71487	17" x 3,50"	TA72667	17" x 5,50"
* 1098	ALL	TA71246	17" x 3,50"	MA72481	17" x 6,00"
* 1198 (ALL MODELS)	'09→	TA71246	17" x 3,50"	MA72481	17" x 6,00"
* 1199 Panigale (ALL MODELS)	'12→	TA71487	17" x 3,50"	MA72481	17" x 6,00"
* 1299 Panigale (ALL MODELS)	'15→	TA71487	17" x 3,50"	MA72481	17" x 6,00"
* 1103 V4 Panigale (ALL MODELS)	'18→	TA71487	17" x 3,50"	MA72481	17" x 6,00"
* Streetfighter 848	ALL	TA71246	17" x 3,50"	MA72164	17" x 5,50"
* Streetfighter	'09→	TA71246	17" x 3,50"	MA72481	17" x 6,00"

MV AGUSTA

* F4	→'09	TA71164	17" x 3,50"	MA72226	17" x 6,00"
* F4 Brutale	→'09	TA71164	17" x 3,50"	MA72226	17" x 6,00"
* 910 R Brutale	→'09	TA71164	17" x 3,50"	MA72226	17" x 6,00"
* F3 675	'11→	TA71520	17" x 3,50"	MA72226xx/550	17" x 5,50"
* F3 800	'13→	TA71520	17" x 3,50"	MA72226xx/550	17" x 5,50"
* Rivale 800	'13→	TA71520	17" x 3,50"	MA72226xx/550	17" x 5,50"
* Brutale 800 (all models)	'14→	TA71520	17" x 3,50"	MA72226xx/550	17" x 5,50"
* F4 Brutale	'10→	TA71443	17" x 3,50"	MA72226	17" x 6,00"
* F4 1000 LH44	'18→	TA71164	17" x 3,50"	MA72226	17" x 6,00"
* Brutale 1090	'13→	TA71443	17" x 3,50"	MA72226	17" x 6,00"

- Questa applicazione richiede un kit specifico Ducati.
- *: Monobraccio
- ** : Lunghezza viti fissaggio disco: 21 mm (senza ABS)
Lunghezza viti fissaggio disco: 23 mm (con ABS)

GS1200 R - Ruote Adventure: verniciatura standard NL (nero lucido) e AGN (argento); anodizzazione standard AN (nero) e ASL (argento). Deve essere utilizzato kit BMW di viti lunghe cod. 36317668389

- This application requires a kit available only from Ducati.
- *: Single arm wheel.
- ** : Disc fixing screw cut lenght : 21mm (not ABS models)
Disc fixing screw cut lenght : 23mm (ABS models)

GS1200 R - Adventure wheels: standard painted colors are NL (gloss black) and AGN (silver); standard anodized colors are AN (black) and ASL (silver); please note that have to be used BMW long screws 36317668389

SM - M10RR KOMPE MOTARD - ALLUMINIO FORGIATO

SM - M10RR KOMPE MOTARD - FORGED ALUMINIUM

Applicazione	Anno	Ruota Anteriore		Ruota Posteriore	
		Dimensione	Codice	Dimensione	Codice
Application	Year	Front Wheel	Code	Rear Wheel	Code
		Size	Code	Size	Code
APRILIA					
SXV 5.5 / SXV 4.5	'08→'12	17" x 3,50"	SM71101350	17" x 5,40"	SM72101540
		16,5" x 3,50"	SM61101350		
BMW					
G 450 X	'08→'11	17" x 3,50"	SM71201350	17" x 5,00"	SM72201500
		16,5" x 3,50"	SM61201350		
HONDA					
CRF 450R	'02→'06	17" x 3,50"	SM71301350	17" x 4,25"	SM72301425
		16,5" x 3,50"	SM61301350	17" x 4,50"	SM72302450
CRF 450R	'07→'12	17" x 3,50"	SM71301350	17" x 5,00"	SM72302500
				17" x 5,40"	SM72302540
		17" x 3,50"	SM71301350	17" x 4,25"	SM72301425
CRF 450R	'13→	16,5" x 3,50"	SM61301350	17" x 4,50"	SM72303450
				17" x 5,00"	SM72303500
				17" x 5,40"	SM72303540
CRF 450R	'13→	17" x 3,50"	SM71301350	17" x 4,25"	SM72306425
		16,5" x 3,50"	SM61301350	17" x 4,50"	SM72307450
CRF 250R	'02→'12	17" x 3,50"	SM71301350	17" x 5,00"	SM72307500
		16,5" x 3,50"	SM61301350	17" x 5,40"	SM72307540
XR 400R	'96→'04	17" x 3,50"	SM71302350	17" x 4,25"	SM72304425
XR 650R / XR 650SM	'00→'07	16,5" x 3,50"	SM61302350		
		17" x 3,50"	SM71302350	17" x 4,25"	SM72305425
		16,5" x 3,50"	SM61302350		
HUSQVARNA					
SM 450R / SM 510R SM 610S / SMS 610	'04→'14	17" x 3,50"	SM71401350	17" x 4,25"	SM72401425
		16,5" x 3,50"	SM61401350	17" x 4,50"	SM72401450
FS 450	'16	17" x 3,50"	SM71602350	17" x 5,00"	SM72603500
		16,5" x 3,50"	SM61602350	17" x 5,40"	SM72603540
SMR 499 / 511	'11→'13	17" x 3,50"	SM71402350	17" x 4,25"	SM72402425
		16,5" x 3,50"	SM61402350	17" x 4,50"	SM72402450
				17" x 5,00"	SM72402500
KAWASAKI					
KX250 / KX250F / KX450F	→'05	17" x 3,50"	SM71501350	17" x 5,00"	SM72501500
		16,5" x 3,50"	SM61501350		
KX450F	'06	17" x 3,50"	SM71502350	17" x 5,00"	SM72501500
		16,5" x 3,50"	SM61502350		
KTM					
450 SMR	'06→'12	17" x 3,50"	SM71602350	17" x 5,00"	SM72602500
		16,5" x 3,50"	SM61602350	17" x 5,40"	SM72602540
450 SMR	'13→'14	17" x 3,50"	SM71602350	17" x 5,00"	SM72603500
		16,5" x 3,50"	SM61602350	17" x 5,40"	SM72603540
450 SMR	'15	17" x 3,50"	SM71603350	17" x 5,00"	SM72603500
		16,5" x 3,50"	SM61603350	17" x 5,40"	SM72603540

SM - M10RR KOMPE MOTARD - ALLUMINIO FORGIATO SM - M10RR KOMPE MOTARD - FORGED ALUMINIUM



Applicazione <i>Application</i>	Anno <i>Year</i>	Ruota Anteriore		Ruota Posteriore	
		Dimensione <i>Size</i>	Codice <i>Front Wheel Code</i>	Dimensione <i>Size</i>	Codice <i>Rear Wheel Code</i>
SUZUKI					
RM-Z450	'05→'12	17" x 3,50"	SM71701350	17" x 4,25"	SM72701425
		16,5" x 3,50"	SM61701350	17" x 4,50"	SM72701450
RM-Z250	'07→'12	17" x 3,50"	SM71701350	17" x 5,00"	SM72701500
		16,5" x 3,50"	SM61701350	17" x 4,25"	SM72701425
DR-Z400SM	'20→'12	17" x 3,50"	SM71702350	17" x 4,50"	SM72701450
		16,5" x 3,50"	SM61702350	17" x 5,00"	SM72701500
DR-Z400S	'00→'12	17" x 3,50"	SM71702350	17" x 4,25"	SM72702425
		16,5" x 3,50"	SM61702350	17" x 4,50"	SM72702450
		16,5" x 3,50"	SM61702350	17" x 5,00"	SM72702500
		17" x 3,50"	SM71702350	17" x 4,50"	SM72703450
YAMAHA					
YZ250F / YZ450F / YZ426F	'01→'08	17" x 3,50"	SM71901350	17" x 4,50"	SM72901450
		16,5" x 3,50"	SM61901350	17" x 5,00"	SM72902500
YZ250F / YZ450F / YZ426F	'09→'13	17" x 3,50"	SM71901350	17" x 5,40"	SM72902540
		16,5" x 3,50"	SM61901350	17" x 4,50"	SM72903450
YZ250F / YZ450F / YZ426F	'14	17" x 3,50"	SM71903350	17" x 5,00"	SM72904500
		16,5" x 3,50"	SM61903350	17" x 5,40"	SM72904540
YZ125 / YZ250	'99→'12	17" x 3,50"	SM71901350	17" x 4,50"	SM72903450
		16,5" x 3,50"	SM61903350	17" x 5,00"	SM72904500
WR250X	'08→'12	17" x 3,50"	SM71901350	17" x 5,40"	SM72904540
		16,5" x 3,50"	SM61901350	17" x 4,50"	SM72901450
WR250F / WR450F	'01→'12	17" x 3,50"	SM71902350	17" x 5,00"	SM72902500
		16,5x3,50	SM61901350	17" x 4,50"	SM72905450
		17" x 3,50"	SM71901350	17" x 4,50"	SM72901450



FM - M10RS CORSE - MAGNESIO FORGIATO FM - M10RS CORSE - FORGED MAGNESIUM

Applicazioni Application	Anno Year	Anteriore Front Wheel	Dim. Originale Original Size	Posteriore Rear Wheel	Dim. Originale Original Size
APRILIA					
Tuono V4 Factory	'11→	FM71234	17" x 3,50"	FM72542	17" x 6,00"
Tuono V4 Factory APRC	'11→	FM71234	17" x 3,50"	FM72542	17" x 6,00"
Tuono V4 Factory / Tuono V4 R / Tuono V4 RR	'17→	FM71234	17" x 3,50"	FM72542	17" x 6,00"
RSV4 Factory / RSV4 R	'09→	FM71234	17" x 3,50"	FM72542	17" x 6,00"
RSV4 RF / RSV4 RR	'17→	FM71234	17" x 3,50"	FM72542	17" x 6,00"
BMW					
S 1000 RR	'09 →'18	FM71430	17" x 3,50"	FM72565	17" x 6,00"
S 1000 RR (casted wheels)	'19→	FM71430	17" x 3,50"	FM72565	17" x 6,00"
S 1000 RR (carbon and forged wheels)	'19 >	FM71614	17" x 3,50"	FM72738	17" x 6,00"
S 1000 R Naked	'14→	FM71430	17" x 3,50"	FM72565	17" x 6,00"
HP 4	'13→	FM71504	17" x 3,50"	FM72632	17" x 6,00"
DUCATI					
* Monster 1100 S	'09→	FM71246	17" x 3,50"	FM72164	17" x 5,50"
* Monster 1100	'09→	FM71246	17" x 3,50"	FM72164	17" x 5,50"
* Monster 796	'10→	FM71246	17" x 3,50"	FM72164	17" x 5,50"
Monster 821	'15→	FM71246	17" x 3,50"	FM72667	17" x 5,50"
* Monster S4R	'03→'06	FM71150	17" x 3,50"	FM72164	17" x 5,50"
* Monster S2R 800	'05→'09	FM71150	17" x 3,50"	FM72164	17" x 5,50"
* Monster S2R 1000	'06→'08	FM71150	17" x 3,50"	FM72164	17" x 5,50"
* Monster S4R Testastretta	'07→'08	FM71246	17" x 3,50"	FM72164	17" x 5,50"
* Monster S4RS Testastretta	'06→'08	FM71246	17" x 3,50"	FM72164	17" x 5,50"
* Monster 1200	'14→	FM71246	17" x 3,50"	FM72481	17" x 6,00"
* Monster 1200 S	'14→	FM71246	17" x 3,50"	FM72481	17" x 6,00"
* Supersport 937	'17→	FM71246	17" x 3,50"	FM72481	17" x 6,00"
* 748/916/996/998	ALL	FM71150	17" x 3,50"	FM72164	17" x 5,50"
* 748/916/996/998	ALL	FM71150	17" x 3,50"	FM72164xx/600	17" x 6,00"
* Multistrada 950	'17→	FM71246	17" x 3,50"	FM72481	17" x 6,00"
* Multistrada 1000 kit	'02→'06	FM71150 • See Note	17" x 3,50"	FM72164	17" x 5,50"
* Multistrada 1100 kit	'07→'08	FM71150 • See Note	17" x 3,50"	FM72164	17" x 5,50"
* Multistrada 1200 (all versions)	'10→	FM71246	17" x 3,50"	FM72481	17" x 6,00"
1260 Multistrada	'18→	FM71246	17" x 3,50"	FM72481	17" x 6,00"
1260 S Multistrada	'18→	FM71246	17" x 3,50"	FM72481	17" x 6,00"
* Hypermotard 796	'10→'11	FM71246	17" x 3,50"	FM72164	17" x 5,50"
* Hypermotard 821	'13→	FM71246	17" x 3,50"	FM72164	17" x 5,50"
* Hypermotard 939	'16→	FM71246	17" x 3,50"	FM72164	17" x 5,50"
* Hypermotard SP 821	'13→	FM71246	17" x 3,50"	FM72164	17" x 5,50"
* Hyperstrada 821	'13→	FM71246	17" x 3,50"	FM72164	17" x 5,50"
* Hyperstrada 939	'16→	FM71246	17" x 3,50"	FM72164	17" x 5,50"
* Hypermotard/848	'08→	FM71246	17" x 3,50"	FM72164	17" x 5,50"
899 Panigale	'13→	FM71487	17" x 3,50"	FM72667	17" x 5,50"
937 Supersport	'17→	FM71246	17" x 3,50"	FM72164	17" x 5,50"
959 Panigale	'13→	FM71487	17" x 3,50"	FM72667	17" x 5,50"
* 1098	ALL	FM71246	17" x 3,50"	FM72481	17" x 6,00"
* 1198 (ALL MODELS)	'09→	FM71246	17" x 3,50"	FM72481	17" x 6,00"
* 1199 Panigale (ALL MODELS)	'12→	FM71487	17" x 3,50"	FM72481	17" x 6,00"
* 1199 Superleggera	'14	FM71487	17" x 3,50"	FM72481	17" x 6,00"
* 1299 Panigale (ALL MODELS)	'12→	FM71487	17" x 3,50"	FM72481	17" x 6,00"
* 1103 V4 Panigale (ALL MODELS)	'18→	FM71487	17" x 3,50"	FM72481	17" x 6,00"
* Streetfighter 848	ALL	FM71246	17" x 3,50"	FM72164	17" x 5,50"
* Streetfighter	'09→	FM71246	17" x 3,50"	FM72481	17" x 6,00"
HONDA					
CBR1000RR Fireblade (NO ABS)	'08→'16	FM71372	17" x 3,50"	FM72390	17" x 6,00"
CBR1000RR Fireblade (ABS)	'08→'16	FM71372	17" x 3,50"	FM72601	17" x 6,00"
CBR1000RR SP	'14→'16	FM71372	17" x 3,50"	FM72601	17" x 6,00"

FM - M10RS CORSE - MAGNESIO FORGIATO FM - M10RS CORSE - FORGED MAGNESIUM



Applicazioni Application	Anno Year	Anteriore Front Wheel	Dim. Originale Original Size	Posteriore Rear Wheel	Dim. Originale Original Size
CBR1000RR	'17→'19	FM71595	17" x 3,50"	FM72724	17" x 6,00"
CBR1000RR SP1	'17→'19	FM71595	17" x 3,50"	FM72724	17" x 6,00"
CBR1000RR SP2	'17→'19	FM71596	17" x 3,50"	FM72724	17" x 6,00"
CBR1000RR-R	'20→	FM71617	17" x 3,50"	FM72742	17" x 6,00"

KAWASAKI

** Ninja ZX-6R	'07→	FM71278	17" x 3,50"	FM72485	17" x 5,50"
** Ninja ZX-10R	'06→'10	FM71278	17" x 3,50"	FM72462	17" x 6,00"
** Ninja ZX-10R (ABS and NO ABS)	'11→'15	FM71278	17" x 3,50"	FM72584	17" x 6,00"
** ZX - 10R	'16→	FM71553	17" x 3,50"	FM72670	17" x 6,00"

KTM

1190 RC8	'08→	FM71362	17" x 3,50"	FM72486	17" x 6,00"
1190 RC8 R	'09→	FM71362	17" x 3,50"	FM72486	17" x 6,00"

MV AGUSTA

* F4	→'09	FM71164	17" x 3,50"	FM72226	17" x 6,00"
* F4 Brutale	→'09	FM71164	17" x 3,50"	FM72226	17" x 6,00"
* 910 R Brutale	→'09	FM71164	17" x 3,50"	FM72226	17" x 6,00"
* F3 675	'11→	FM71520	17" x 3,50"	FM72226xx/550	17" x 5,50"
* F3 800	'13→	FM71520	17" x 3,50"	FM72226xx/550	17" x 5,50"
* Rivale 800	'13→	FM71520	17" x 3,50"	FM72226xx/550	17" x 5,50"
* Brutale 800	'14→	FM71520	17" x 3,50"	FM72226xx/550	17" x 5,50"
* F4 1000 LH44	'18→	FM71520	17" x 3,50"	FM72226	17" x 6,00"
* F4 e Brutale	'10→	FM71443	17" x 3,50"	FM72226	17" x 6,00"
* Brutale 1090	'10→	FM71443	17" x 3,50"	FM72226	17" x 6,00"

SUZUKI

GSX-R 600 / GSX-R 750	'08→'10	FM71380	17" x 3,50"	FM72461	17" x 5,50"
GSX-R 600 / GSX-R 750	'11→	FM71466	17" x 3,50"	FM72600	17" x 5,50"
GSX-R 1000	'05→'08	FM71303	17" x 3,50"	FM72431	17" x 6,00"
GSX-R 1000	'09→ '16	FM71380	17" x 3,50"	FM72514	17" x 6,00"
GSX-R 1000	'17→	FM71380	17" x 3,50"	FM72728	17" x 6,00"

YAMAHA

YZF-R6	'03→'16	FM71259	17" x 3,50"	FM72366	17" x 5,50"
YZF-R6	'17→	FM71546	17" x 3,50"	FM72733	17" x 5,50"
YZF-R1	'04→'14	FM71259	17" x 3,50"	FM72377	17" x 6,00"
YZF-R1	'15→	FM71546	17" x 3,50"	FM72669	17" x 6,00"
MT-10	'16→	FM71546	17" x 3,50"	FM72669	17" x 6,00"

- Questa applicazione richiede un kit specifico Ducati.
- ** : Lunghezza viti fissaggio disco: 21 mm (senza ABS)
Lunghezza viti fissaggio disco: 23 mm (con ABS)

- This application requires a kit available only from Ducati.
- ** : Disc fixing screw cut length : 21mm (not ABS models)
Disc fixing screw cut length : 23mm (ABS models)

Colori Standard: Nero Lucido - Nero Opaco - Oro.

Standard Colours: Glossy Black - Matte Black - Gold.



AS - M7RS GENESI - ALLUMINIO FORGIATO AS - M7RS GENESI - FORGED ALLUMINIUM

Applicazioni Application	Anno Year	Anteriore Front Wheel	Dim. Originale Original Size	Posteriore Rear Wheel	Dim. Originale Original Size
APRILIA					
Tuono V4 Factory	11→	AS71234	17" x 3,50"	AS72542	17" x 6,00"
Tuono V4 Factory APRC	11→	AS71234	17" x 3,50"	AS72542	17" x 6,00"
RSV4 Factory / RSV4 R	09→	AS71234	17" x 3,50"	AS72542	17" x 6,00"
BMW					
S 1000 RR	09→'18	AS71430	17" x 3,50"	AS72565	17" x 6,00"
S 1000 RR (casted wheels)	19→	AS71430	17" x 3,50"	AS72565	17" x 6,00"
S 1000 RR (carbon and forged wheels)	19→	AS71614	17" x 3,50"	AS72738	17" x 6,00"
S 1000 R Naked	14→	AS71430	17" x 3,50"	AS72565	17" x 6,00"
HP 4	13→	AS71504	17" x 3,50"	AS72632	17" x 6,00"
DUCATI					
899 Panigale	13→	AS71487	17" x 3,50"	AS72667	17" x 5,50"
959 Panigale	16→	AS71487	17" x 3,50"	AS72667	17" x 5,50"
* Monster 1200	14→	AS71246	17" x 3,50"	AS72481	17" x 6,00"
* Monster 1200 S	14→	AS71246	17" x 3,50"	AS72481	17" x 6,00"
* Supersport 937	17→	AS71246	17" x 3,50"	AS72481	17" x 6,00"
* Multistrada 950	17→	AS71246	17" x 3,50"	AS72481	17" x 6,00"
* Multistrada 1200 (all versions)	10→	AS71246	17" x 3,50"	AS72481	17" x 6,00"
* 1260 Multistrada	18→	AS71246	17" x 3,50"	AS72481	17" x 6,00"
* 1260 S Multistrada	18→	AS71246	17" x 3,50"	AS72481	17" x 6,00"
* 1098	ALL	AS71246	17" x 3,50"	AS72481	17" x 6,00"
* 1198 (ALL MODELS)	09→	AS71246	17" x 3,50"	AS72481	17" x 6,00"
* 1199 Panigale (ALL MODELS)	12→	AS71487	17" x 3,50"	AS72481	17" x 6,00"
* 1299 Panigale (ALL MODELS)	15→	AS71487	17" x 3,50"	AS72481	17" x 6,00"
* 1103 V4 Panigale (ALL MODELS)	18→	AS71487	17" x 3,50"	AS72481	17" x 6,00"
* Streetfighter	09→	AS71246	17" x 3,50"	AS72481	17" x 6,00"
HONDA					
CBR1000RR Fireblade (no ABS)	08→'16	AS71372	17" x 3,50"	AS72390	17" x 6,00"
CBR1000RR Fireblade (ABS)	08→'16	AS71372	17" x 3,50"	AS72601	17" x 6,00"
CBR1000RR SP	14→'16	AS71372	17" x 3,50"	AS72601	17" x 6,00"
CBR1000RR	17→'19	AS71595	17" x 3,50"	AS72724	17" x 6,00"
CBR1000RR SP1	17→'19	AS71595	17" x 3,50"	AS72724	17" x 6,00"
CBR1000RR SP2	17→'19	AS71596	17" x 3,50"	AS72724	17" x 6,00"
CBR1000RR-R	20→	AS71617	17" x 3,50"	AS72742	17" x 6,00"
KAWASAKI					
** Ninja ZX-6R	07→	AS71278	17" x 3,50"	AS72485	17" x 5,50"
** Ninja ZX-10R	06→'10	AS71278	17" x 3,50"	AS72462	17" x 6,00"
** Ninja ZX-10R (ABS and NO ABS)	11→'15	AS71278	17" x 3,50"	AS72584	17" x 6,00"
** ZX - 10R	16→	AS71553	17" x 3,50"	AS72670	17" x 6,00"
** ZX - 10RR	17→	AS71604	17" x 3,50"	AS72734	17" x 6,00"
KTM					
1190 RC8	08→	AS71362	17" x 3,50"	AS72486	17" x 6,00"
1190 RC8 R	09→	AS71362	17" x 3,50"	AS72486	17" x 6,00"
SUZUKI					
GSX-R 600 / GSX-R 750	08→'10	AS71380	17" x 3,50"	AS72461	17" x 5,50"
GSX-R 600 / GSX-R 750	11→	AS71466	17" x 3,50"	AS72600	17" x 5,50"
GSX-R 1000	05→'08	AS71303	17" x 3,50"	AS72431	17" x 6,00"

AS - M7RS GENESI - ALLUMINIO FORGIATO AS - M7RS GENESI - FORGED ALLUMINIUM



Applicazioni Application	Anno Year	Anteriore Front Wheel	Dim. Originale Original Size	Posteriore Rear Wheel	Dim. Originale Original Size
GSX-R 1000	09→'16	AS71380	17" x 3,50"	AS72514	17" x 6,00"
GSX-R 1000	17→	AS71380	17" x 3,50"	AS72728	17" x 6,00"

YAMAHA

YZF-R6	03→'16	AS71259	17" x 3,50"	AS72366	17" x 5,50"
YZF-R6	17→	AS71546	17" x 3,50"	AS72733	17" x 5,50"
YZF-R1	04→'14	AS71259	17" x 3,50"	AS72377	17" x 6,00"
YZF-R1	15→	AS71546	17" x 3,50"	AS72669	17" x 6,00"
MT-10	16→	AS71546	17" x 3,50"	AS72669	17" x 6,00"

** : L1 viti fissaggio disco: 21 mm (senza ABS), 23 mm (con ABS)
Colori Standard: Nero Lucido - Nero Opaco - Oro.

Per il trattamento antislip, aggiungere una "X" dopo il suffisso colore.

** : Fixing screw lenght: 21mm (no ABS mod.), 23mm (ABS mod.)
Standard Colours: Glossy Black - Matte Black - Gold.

Please add a final "X" for antislip treatment after color suffix.



FS - M7R GENESI - MAGMESIO FORGIATO

FS - M7R GENESI - FORGED MAGNESIUM

Applicazioni <i>Application</i>	Anno <i>Year</i>	Anteriore <i>Front Wheel</i>	Dim. Originale <i>Original Size</i>	Posteriore <i>Rear Wheel</i>	Dim. Originale <i>Original Size</i>
APRILIA					
RSV 1000 R	'06→'08	FS71234	17" x 3,50"	FS72363	17" x 6,00"
RSV 1000 R Factory	'06→'08	FS71234	17" x 3,50"	FS72363	17" x 6,00"
Tuono V4 Factory	'11→	FS71234	17" x 3,50"	FS72542	17" x 6,00"
Tuono V4 Factory APRC	'11→	FS71234	17" x 3,50"	FS72542	17" x 6,00"
RSV4 Factory / RSV4 R	'09→	FS71234	17" x 3,50"	FS72542	17" x 6,00"
BIMOTA					
DB5	'05→	FS71338	17" x 3,50"	FS72463	17" x 5,50"
DB6 Delirio	'06→	FS71338	17" x 3,50"	FS72463	17" x 5,50"
BMW					
S 1000 RR	'09→'18	FS71430	17" x 3,50"	FS72565	17" x 6,00"
S 1000 RR (casted wheels)	'19→	FS71430	17" x 3,50"	FS72565	17" x 6,00"
S 1000 RR (carbon and forged wheels)	'19→	FS71614	17" x 3,50"	FS72738	17" x 6,00"
S 1000 R Naked	'14→	FS71430	17" x 3,50"	FS72565	17" x 6,00"
HP 4	'13→	FS71504	17" x 3,50"	FS72632	17" x 6,00"
DUCATI					
899 Panigale	'13→	FS71487	17" x 3,50"	FS72667	17" x 5,50"
959 Panigale	'16→	FS71487	17" x 3,50"	FS72667	17" x 5,50"
749/749S/999/999S/999R	ALL	FS71246	17" x 3,50"	FS72354	17" x 6,00"
Desmosedici RR	ALL	FS71398	17" x 3,50"	FS72530	17" x 6,00"
HONDA					
CBR600RR	'07→	FS71359	17" x 3,50"	FS72477	17" x 5,50"
CBR1000RR Fireblade	'04→'07	FS71216	17" x 3,50"	FS72390	17" x 6,00"
CBR1000RR Fireblade (NO ABS)	'08→'16	FS71372	17" x 3,50"	FS72390	17" x 6,00"
CBR1000RR Fireblade (ABS)	'08→'16	FS71372	17" x 3,50"	FS72601	17" x 6,00"
CBR1000RR SP	'14→'16	FS71372	17" x 3,50"	FS72601	17" x 6,00"
CBR1000RR	'17→'19	FS71595	17" x 3,50"	FS72724	17" x 6,00"
CBR1000RR SP1	'17→'19	FS71595	17" x 3,50"	FS72724	17" x 6,00"
CBR1000RR SP2	'17→'19	FS71596	17" x 3,50"	FS72724	17" x 6,00"
CBR1000RR-R	'20→	FS71617	17" x 3,50"	FS72742	17" x 6,00"
KAWASAKI					
** Ninja ZX-6R	'07→	FS71278	17" x 3,50"	FS72485	17" x 5,50"
** Ninja ZX-10R	'04→'05	FS71277	17" x 3,50"	FS72391	17" x 6,00"
** Ninja ZX-10R	'06→'10	FS71278	17" x 3,50"	FS72462	17" x 6,00"
** Ninja ZX-10R (ABS and NO ABS)	'11→'15	FS71278	17" x 3,50"	FS72584	17" x 6,00"
** ZX - 10R	'16→	FS71553	17" x 3,50"	FS72670	17" x 6,00"
KTM					
1190 RC8	'08→	FS71362	17" x 3,50"	FS72486	17" x 6,00"
1190 RC8-R	'09→	FS71362	17" x 3,50"	FS72486	17" x 6,00"
SUZUKI					
GSX-R 600 / GSX-R 750	'06→'07	FS71303	17" x 3,50"	FS72461	17" x 5,50"
GSX-R 600 / GSX-R 750	'08→'10	FS71380	17" x 3,50"	FS72461	17" x 5,50"
GSX-R 600 / GSX-R 750	'11→	FS71466	17" x 3,50"	FS72600	17" x 5,50"
GSX-R 1000	'01→'04	FS71220	17" x 3,50"	FS72330	17" x 6,00"
GSX-R 1000	'05→'08	FS71303	17" x 3,50"	FS72431	17" x 6,00"
GSX-R 1000	'09→'16	FS71380	17" x 3,50"	FS72514	17" x 6,00"
GSX-R 1000	'17→	FS71380	17" x 3,50"	FS72728	17" x 6,00"

FS - M7R GENESI - MAGMESIO FORGIATO FS - M7R GENESI - FORGED MAGNESIUM



Applicazioni Application	Anno Year	Anteriore Front Wheel	Dim. Originale Original Size	Posteriore Rear Wheel	Dim. Originale Original Size
YAMAHA					
YZF-R6	'03→'16	FS71259	17" x 3,50"	FS72366	17" x 5,50"
YZF-R6	'17→	FS71546	17" x 3,50"	FS72733	17" x 5,50"
YZF-R1	'02→'03	FS71186	17" x 3,50"	FS72347	17" x 6,00"
YZF-R1	'04→'14	FS71259	17" x 3,50"	FS72377	17" x 6,00"
YZF-R1	'15→	FS71546	17" x 3,50"	FS72669	17" x 6,00"
MT-10	'16→	FS71546	17" x 3,50"	FS72669	17" x 6,00"

** : L1 viti fissaggio disco: 21 mm (senza ABS), 23 mm (con ABS)
Colori Standard: Nero Lucido - Nero Opaco - Oro.

Per il trattamento antislip, aggiungere una "X" dopo il suffisso colore.

** : Fixing screw lenght: 21mm (no ABS mod.), 23mm (ABS mod.)
Standard Colours: Glossy Black - Matte Black - Gold.

Please add a final "X" for antislip treatment after color suffix.



TA - M10RS KOMPE MOTO 3 - ALLUMINIO FORGIATO
TA - M10RS KOMPE MOTO 3 - FORGED ALUMINUM

Applicazioni Application	Anno Year	Anteriore Front Wheel	Dim. Originale Original Size	Posteriore Rear Wheel	Dim. Originale Original Size
APRILIA					
22 mm axle		TA71482	17" x 2,50"	TA72607	17" x 3,50"
HONDA					
15 mm axle		TA71480	17" x 2,50"	TA72606	17" x 3,50"
17 mm axle		TA71497	17" x 2,50"	TA72627	17" x 3,50"
20 mm axle		TA71481	17" x 2,50"	TA72613	17" x 3,50"

F - M10RS CORSE MOTO 3 - MAGMESIO FORGIATO
F - M10RS CORSE MOTO 3 - FORGED MAGNESIUM

APRILIA					
22 mm axle		F71482	17" x 2,50"	F72607	17" x 3,50"
HONDA					
15 mm axle		F71480	17" x 2,50"	F72606	17" x 3,50"
17 mm axle		F71497	17" x 2,50"	F72627	17" x 3,50"
20 mm axle		F71481	17" x 2,50"	F72613	17" x 3,50"

Colori Standard: Nero Lucido - Nero Opaco - Oro.

Standard Colours: Glossy Black - Matte Black - Gold

Per il trattamento antislip, aggiungere una "X" dopo il suffisso colore.

Please add a final "X" for antislip treatment after color suffix.

FILTRI OLIO





Filtri Olio ad Alta Tecnologia.

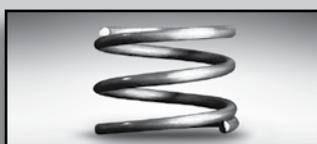

MOLLA

Realizzata con materiale eccellente, mantiene il corretto accoppiamento tra cartuccia e corpo.



VALVOLA BY-PASS

Permette il flusso d'olio di sicurezza anche in caso di alta differenza di pressione (filtro intasato).



SPIRALE

Grazie alla sua conformazione, sostiene l'elemento filtrante e consente il migliore flusso d'olio possibile.



CARTUCCIA

Le specifiche costruttive forniscono un elevato rapporto tra grado di filtraggio e durata del filtro stesso.



VALVOLA NON-RITORNO

Impedisce gli eventuali flussi di ritorno nel circuito di lubrificazione.



FONDELLO

Doppio sistema di aggancio tra piattello e corpo, per garantire la massima resistenza alle sollecitazioni meccaniche.



TENUTE

Guarnizioni a profilo quadro, evitano perdite ed assicurano i corretti flussi interni al filtro.

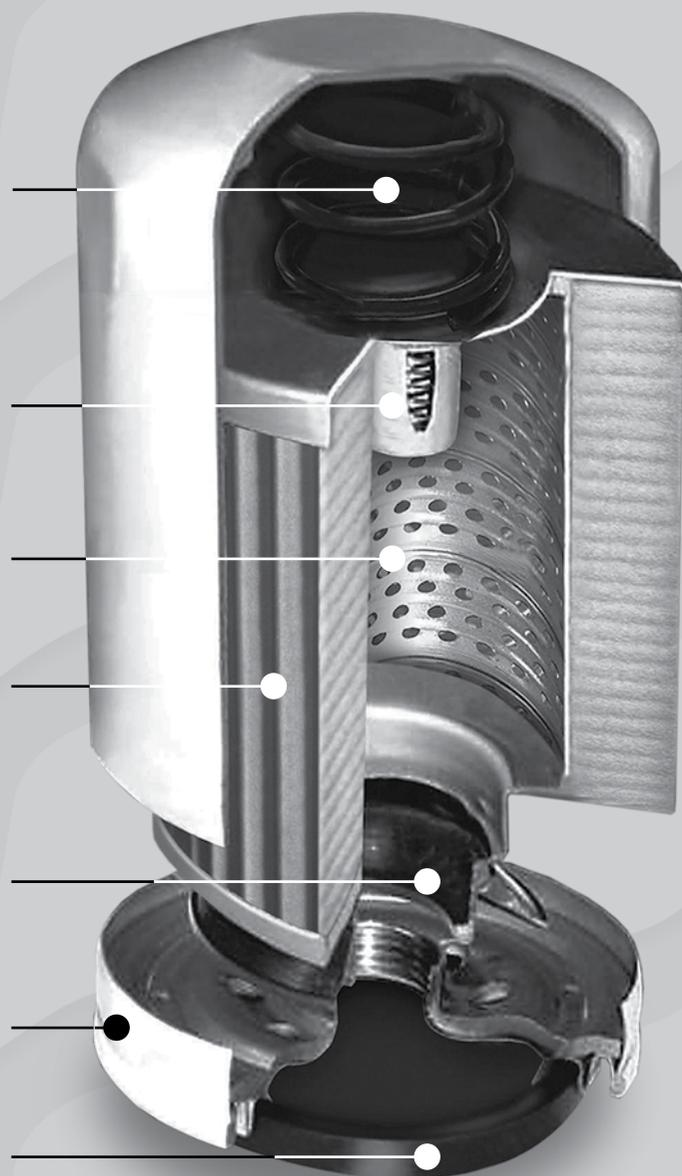



FILTRI ISON / ISON FILTER

CC	Modello Model	Anno Years	Codice Code	€
ADIVA SCOOTERS				
125	AD	'08→'10	ISON183	5,39
250	AD	'06→'11	ISON183	5,39
400	AD	'09→'11	ISON184	6,41

ADLY

300	Interceptor	'05→'07	ISON112	3,34
300	Utility	'05→'07	ISON112	3,34
500	S ATV	'08→'10	ISON112	3,34

APRILIA

125	Atlantic	'03→'13	ISON183	5,39
125	Leonardo	'96→'98	ISON185	3,47
125	Leonardo	'99→'01	ISON185	3,47
125	Leonardo ST	'02→'04	ISON185	3,47
125	Mojito	'0→'12	ISON183	5,39
125	Mojito Custom	'03→'12	ISON183	5,39
125	Mojito E3	'08	ISON183	5,39
125	RS4	'11→'20	ISON563	8,31
125	RS4 GP Replica	'18→'20	ISON563	8,31
125	Scarabeo	'99→'04	ISON185	3,47
125	Scarabeo	'03→'06	ISON183	5,39
125	Scarabeo GT	'04→'06	ISON183	5,39
125	Sportcity	'04→'08	ISON183	5,39
125	Sportcity Cube	'08→'12	ISON183	5,39
125	Sportcity One	'08→'12	ISON183	5,39
125	Sportcity Street	'12→'12	ISON183	5,39
125	SR MAX	'11→'16	ISON183	5,39
125	SR Motard	'12→'16	ISON183	5,39
125	Tuono 4T	'17→'20	ISON563	8,31
150	Leonardo	'96→'01	ISON185	3,47
150	Leonardo ST	'02→'04	ISON185	3,47
150	Mojito	'03→'07	ISON183	5,39
150	Scarabeo	'99→'04	ISON185	3,47
150	Scarabeo GT	'04→'06	ISON185	3,47
200	Atlantic	'03→'05	ISON183	5,39
200	Scarabeo	'99→'04	ISON185	3,47
200	Scarabeo	'03→'06	ISON183	5,39
200	Sportcity	'04→'08	ISON183	5,39
200	Sportcity Cube	'08→'09	ISON183	5,39
250	Atlantic	'03→'05	ISON183	5,39
250	Atlantic IE	'06→'08	ISON183	5,39
250	Scarabeo	'04→'06	ISON183	5,39
250	Scarabeo Light E3	'06→'10	ISON183	5,39
250	Sportcity Cube IE	'08→'12	ISON183	5,39
250	Sportcity IE	'06→'08	ISON183	5,39
300	Atlantic	'10→'11	ISON183	5,39
300	Scarabeo Light E3	'09→'11	ISON183	5,39
300	Sport Cube	'11	ISON183	5,39
300	Sportcity Cube IE	'08→'12	ISON183	5,39
300	Sportcity Street	'12→'12	ISON183	5,39
300	SR Max	'11→'16	ISON183	5,39
350	ETX Tuareg	'85→'87	ISON151	6,42
350	ETX Tuareg Wind	'88→'89	ISON151	6,42
400	Atlantic Sprint	'05→'08	ISON184	6,41
400	Scarabeo Light	'06→'10	ISON184	6,41
450	RXV	'06→'13	ISON563	8,31
450	SXV Supermoto	'06→'13	ISON563	8,31
450	SXV Van Den Bosch Replica	'08	ISON563	8,31
500	Atlantic	'01→'04	ISON184	6,41

CC	Modello Model	Anno Years	Codice Code	€
500	Atlantic Sprint	'05→'10	ISON184	6,41
500	Scarabeo ABS	'03→'06	ISON184	6,41
500	Scarabeo Classic	'10→'12	ISON184	6,41
500	Scarabeo GT ABS	'05→'07	ISON184	6,41
500	Scarabeo IE	'07→'12	ISON184	6,41
500	Scarabeo LIGHT	'06→'06	ISON184	6,41
550	RXV	'06→'13	ISON563	8,31
550	SXV Supermoto	'06→'13	ISON563	8,31
550	SXV Van Den Bosch Replica	'08	ISON563	8,31
600	ETX Tuareg	'85→'87	ISON151	6,42
600	Pegaso	'90→'92	ISON151	6,42
600	Tuareg Wind	'87→'91	ISON151	6,42
650	Motò 6.5	'95→'01	ISON151	6,42
650	Pegaso	'93→'96	ISON151	6,42
650	Pegaso IE	'01→'04	ISON151	6,42
650	Pegaso IE Factory	'06→'10	ISON145	4,77
650	Pegaso IE Strada	'05→'10	ISON145	4,77
650	Pegaso IE Trail	'06→'08	ISON145	4,77
650	Pegaso III	'97→'01	ISON151	6,42
750	Dorsoduro	'08→'12	ISON565	9,47
750	Dorsoduro ABS	'13→'16	ISON565	9,47
750	Dorsoduro Factory	'10→'13	ISON565	9,47
750	Dorsoduro Factory ABS	'10→'13	ISON565	9,47
750	Shiver	'07→'16	ISON565	9,47
750	Shiver ABS	'13→'16	ISON565	9,47
750	Shiver GT	'09→'10	ISON565	9,47
750	Shiver GT ABS	'10→'13	ISON565	9,47
850	Mana	'07→'13	ISON565	9,47
850	Mana ABS	'13	ISON565	9,47
850	SRV	'12	ISON565	9,47
850	SRV ABS	'12→'14	ISON565	9,47
900	Dorsoduro ABS	'17→'20	ISON565	9,47
900	Shiver ABS	'17→'20	ISON565	9,47
1000	ETV Caponord	'01→'03	ISON152	8,34
1000	ETV Caponord ABS	'04→'08	ISON152	8,34
1000	ETV Caponord Rally	'01→'09	ISON152	8,34
1000	RST Futura	'01→'04	ISON152	8,34
1000	RSV	'98→'04	ISON152	8,34
1000	RSV Dream	'04→'08	ISON152	8,34
1000	RSV Factory	'04→'08	ISON152	8,34
1000	RSV R	'00→'08	ISON152	8,34
1000	RSV SP	'99→'00	ISON152	8,34
1000	RSV4 APRC R	'11→'12	ISON138	8,06
1000	RSV4 APRC R ABS	'13→'14	ISON138	8,06
1000	RSV4 APRC SE	'11→'12	ISON138	8,06
1000	RSV4 APRC STD	'11→'12	ISON138	8,06
1000	RSV4 Factory	'09→'10	ISON138	8,06
1000	RSV4 Factory APRC ABS	'13→'14	ISON138	8,06
1000	RSV4 R	'09→'10	ISON138	8,06
1000	RSV4 RF	'15→'19	ISON138	8,06
1000	RSV4 RR	'15→'20	ISON138	8,06
1000	RSV4 RR Racer Pack	'15	ISON138	8,06
1000	RSV4 SBK Racing	'09→'10	ISON138	8,06
1000	SL Falco	'99→'04	ISON152	8,34
1000	Tuono	'02→'05	ISON152	8,34
1000	Tuono R	'02→'10	ISON152	8,34
1000	Tuono R Factory	'06→'10	ISON152	8,34
1000	Tuono V4 R	'11→'15	ISON138	8,06
1000	Tuono V4 R APRC	'11→'13	ISON138	8,06
1000	Tuono V4 R APRC ABS	'13→'15	ISON138	8,06
1100	RSV4 Factory	'19→'20	ISON138	8,06
1100	Tuono V4 Factory	'15→'20	ISON138	8,06



FILTRI ISON / ISON FILTER

CC	Modello Model	Anno Years	Codice Code	€
1100	Tuono V4 RR	'15→'20	ISON138	8,06
1200	Caponord	'13→'16	ISON565	9,47
1200	Caponord Rally	'15→'19	ISON565	9,47
1200	Caponord Travel Pack	'13→'17	ISON565	9,47
1200	Dorsoduro	'10→'11	ISON565	9,47
1200	Dorsoduro ABS	'12→'15	ISON565	9,47

ARCTIC CAT

250	2X4	'99→'05	ISON132	3,34
250	4X4	'99→'05	ISON132	3,34
300	2X4	'98→'05	ISON132	3,34
300	4X4	'98→'05	ISON132	3,34
400	2X4	'03→'04	ISON138	8,06
400	4X4	'04→'07	ISON138	8,06
400	4X4 ACT	'04	ISON138	8,06
400	4X4 ACT Auto	'04	ISON138	8,06
400	4X4 Automatic	'03→'08	ISON138	8,06
400	4X4 Automatic LE	'05→'07	ISON138	8,06
400	4X4 Automatic TBX	'04→'06	ISON138	8,06
400	4X4 Automatic TRV	'06→'07	ISON138	8,06
400	4X4 Automatic VP	'05→'06	ISON138	8,06
400	4X4 VP	'05→'06	ISON138	8,06
400	DVX	'04→'08	ISON139	4,26
454	Bear Cat 2X4/4X4	'96→'98	ISON138	8,06
500	4X4	'04→'08	ISON138	8,06
500	4X4 Automatic	'04→'07	ISON138	8,06
500	4X4 Automatic LE	'05→'06	ISON138	8,06
500	4X4 Automatic TBX	'04→'06	ISON138	8,06
500	4X4 Automatic TRV	'04→'06	ISON138	8,06
500	Artic Cat	'98→'04	ISON138	8,06
600	4X4	'04→'04	ISON204	8,06
600	4X4 LE	'04→'04	ISON204	8,06
650	4X4 V2	'06→'06	ISON204	8,06
650	4X4 V2 Automatic	'04→'05	ISON204	8,06
650	4X4 V2 Automatic LE	'04→'05	ISON204	8,06
650	4X4 V2 LE	'06	ISON204	8,06
1056	Bearcat	'07→'11	ISON138	8,06

BENELLI

125	Adiva	'00→'02	ISON183	5,39
150	Adiva	'00→'04	ISON183	5,39

BETA

125	RR Enduro	'11→'20	ISON141	5,56
125	RR Motard	'11→'20	ISON141	5,56
200	ALP	'00→'18	ISON132	3,34
250	EVO 2T	'14→'14	ISON207	4,54
250	EVO 4T	'09→'19	ISON207	4,54
250	REV 4T	'07→'08	ISON207	4,54
250	RR Enduro	'05→'09	ISON155	5,50
250	RR Enduro	'05→'09	ISON157	5,67
300	EVO 4T	'10→'20	ISON207	4,54
300	EVO Factory 4T	'19→'19	ISON207	4,54
350	ALP 4.0	'05→'15	ISON136	4,89
350	EURO	'00→'06	ISON136	4,89
350	Jonathan	'03→'06	ISON136	4,89
350	M4 Motard	'07→'15	ISON136	4,89
350	M4 Supermotard	'04→'06	ISON136	4,89
400	RR Enduro	'05→'09	ISON155	5,50
400	RR Enduro	'05→'09	ISON157	5,67

CC	Modello Model	Anno Years	Codice Code	€
450	RR Enduro	'05→'09	ISON155	5,50
450	RR Enduro	'05→'09	ISON157	5,67
450	RR Enduro Racing	'06→'09	ISON155	5,50
450	RR Enduro Racing	'06→'09	ISON157	5,67
525	RR Enduro	'05→'09	ISON155	5,50
525	RR Enduro	'05→'09	ISON157	5,67
525	RR Enduro Racing	'06→'06	ISON155	5,50
525	RR Enduro Racing	'06→'06	ISON157	5,67
525	RR Enduro Racing	'09→'09	ISON155	5,50
525	RR Enduro Racing	'09→'09	ISON157	5,67

BMW

125	C1	'99→'03	ISON185	3,47
200	C1	'01→'03	ISON185	3,47
400	C 400 GT	'19→'20	ISON164	10,43
400	C 400 X	'18→'20	ISON164	10,43
450	G 450 X	'08→'11	ISON611	6,07
450	R 45	'78→'85	ISON161	6,39
450	R 45 N	'78→'85	ISON161	6,39
450	R 45 T	'80→'85	ISON161	6,39
500	R 50 /5	'69→'73	ISON161	6,39
600	C 600 Sport	'11→'17	ISON164	10,43
600	R 60 /5	'69→'73	ISON161	6,39
600	R 60 /6	'73→'76	ISON161	6,39
600	R 60 /7	'76→'80	ISON161	6,39
600	R 60 TIC	'78→'82	ISON161	6,39
650	C 650 GT	'11→'20	ISON164	10,43
650	C 650 Sport	'15→'20	ISON164	10,43
650	F 650	'93→'00	ISON151	6,42
650	F 650 CS Scarver	'00→'07	ISON151	6,42
650	F 650 Funduro	'97→'03	ISON151	6,42
650	F 650 GS	'99→'07	ISON151	6,42
650	F 650 GS	'08→'12	ISON160	10,43
650	F 650 GS 30 Years GS	'11→'11	ISON160	10,43
650	F 650 GS Dakar	'99→'07	ISON151	6,42
650	F 650 ST	'96→'02	ISON151	6,42
650	G 650 GS	'08→'15	ISON151	6,42
650	G 650 GS Sertão	'12→'14	ISON151	6,42
650	G 650 Xchallenge	'07→'09	ISON151	6,42
650	G 650 Xcountry	'06→'09	ISON151	6,42
650	G 650 Xmoto	'07→'09	ISON151	6,42
650	R 65	'88→'89	ISON161	6,39
650	R 65 G/S	'87→'92	ISON161	6,39
650	R 65 LS	'81→'85	ISON161	6,39
650	R 65 RT	'85→'88	ISON161	6,39
650	R 65 T	'80→'85	ISON161	6,39
700	F 700 GS	'11→'18	ISON160	10,43
750	F 750 GS	'17→'20	ISON160	10,43
750	K 75	'84→'96	ISON163	10,51
750	K 75 /2	'84→'96	ISON163	10,51
750	K 75 ABS	'90→'95	ISON163	10,51
750	K 75 C	'85→'90	ISON163	10,51
750	K 75 RT	'89→'96	ISON163	10,51
750	K 75 RT ABS	'89→'96	ISON163	10,51
750	K 75 S	'84→'96	ISON163	10,51
750	K 75 S ABS	'85→'96	ISON163	10,51
750	R 75 /5	'69→'73	ISON161	6,39
750	R 75 /6	'73→'76	ISON161	6,39
750	R 75 /7	'73→'79	ISON161	6,39
800	F 800 GS	'08→'18	ISON160	10,43
800	F 800 GS 30 Years GS	'11→'11	ISON160	10,43



FILTRI ISON / ISON FILTER

CC	Modello Model	Anno Years	Codice Code	€	CC	Modello Model	Anno Years	Codice Code	€
800 F	800 GS Adventure	'12→'18	ISON160	10,43	1100 R	1100 RT	'94→'01	ISON163	10,51
800 F	800 GS Triple Black	'12→'12	ISON160	10,43	1100 R	1100 RT ABS	'94→'01	ISON163	10,51
800 F	800 GS Trophy	'12→'12	ISON160	10,43	1100 R	1100 S	'96→'06	ISON163	10,51
800 F	800 GT	'11→'20	ISON160	10,43	1100 R	1100 S ABS	'00→'06	ISON163	10,51
800 F	800 R	'05→'20	ISON160	10,43	1150 R	1150 GS	'99→'04	ISON163	10,51
800 F	800 R Chris Pfeiffer Edition	'09→'11	ISON160	10,43	1150 R	1150 GS ABS	'99→'04	ISON163	10,51
800 F	800 S	'06→'11	ISON160	10,43	1150 R	1150 GS Adventure	'02→'05	ISON163	10,51
800 F	800 ST	'06→'12	ISON160	10,43	1150 R	1150 GS Adventure (Integral ABS)	'02→'05	ISON163	10,51
800 R	80	'77→'95	ISON161	6,39	1150 R	1150 R	'99→'06	ISON163	10,51
800 R	80 GS	'80→'96	ISON161	6,39	1150 R	1150 R Rockster	'03→'06	ISON163	10,51
800 R	80 Mystic	'94→'95	ISON161	6,39	1150 R	1150 RS	'01→'05	ISON163	10,51
800 R	80 R	'91→'94	ISON161	6,39	1150 R	1150 RS ABS	'01→'05	ISON163	10,51
800 R	80 RT	'82→'95	ISON161	6,39	1150 R	1150 RT	'00→'06	ISON163	10,51
800 R	80 ST	'82→'84	ISON161	6,39	1150 R	1150 RT ABS	'00→'06	ISON163	10,51
800 R	80 TIC	'78→'79	ISON161	6,39	1170 HP2	Enduro	'05→'08	ISON164	10,43
800 R	80 TIC	'80→'80	ISON161	6,39	1170 HP2	Megamoto	'07→'11	ISON164	10,43
800 R	80 TIC	'81→'85	ISON161	6,39	1170 HP2	Sport	'08→'11	ISON164	10,43
850 F	850 GS	'18→'20	ISON160	10,43	1170 R	Ninet	'13→'20	ISON164	10,43
850 F	850 GS Adventure	'18→'20	ISON160	10,43	1170 R	Ninet Pure	'17→'20	ISON164	10,43
850 R	850 C	'97→'00	ISON163	10,51	1170 R	Ninet Racer	'17→'20	ISON164	10,43
850 R	850 GS	'96→'00	ISON163	10,51	1170 R	Ninet Scrambler	'16→'20	ISON164	10,43
850 R	850 GS ABS	'96→'00	ISON163	10,51	1170 R	Ninet Urban GS	'17→'20	ISON164	10,43
850 R	850 R	'94→'07	ISON163	10,51	1200 K	1200 GT	'03→'05	ISON163	10,51
850 R	850 RT	'96→'06	ISON163	10,51	1200 K	1200 GT	'04→'08	ISON160	10,43
900 F	900 R	'20	ISON160	10,43	1200 K	1200 LT	'97→'09	ISON163	10,51
900 F	900 XR	'20	ISON160	10,43	1200 K	1200 R	'05→'08	ISON160	10,43
900 R	90 /6	'73→'76	ISON161	6,39	1200 K	1200 R Sport	'07→'11	ISON160	10,43
900 R	90 S	'73→'76	ISON161	6,39	1200 K	1200 RS	'96→'04	ISON163	10,51
900 R	900 RT	'05→'10	ISON164	10,43	1200 K	1200 RS ABS	'96→'04	ISON163	10,51
1000 HP4		'13→'14	ISON160	10,43	1200 K	1200 S	'03→'08	ISON160	10,43
1000 HP4	RACE	'17→'18	ISON160	10,43	1200 R	1200 C	'97→'05	ISON163	10,51
1000 K	1	'88→'93	ISON163	10,51	1200 R	1200 C ABS	'97→'05	ISON163	10,51
1000 K	1 ABS	'88→'93	ISON163	10,51	1200 R	1200 C Classic	'03→'04	ISON163	10,51
1000 K	100	'83→'89	ISON163	10,51	1200 R	1200 C Independent	'00→'04	ISON163	10,51
1000 K	100 /2	'87→'90	ISON163	10,51	1200 R	1200 C Montauk	'04→'04	ISON163	10,51
1000 K	100 /2 ABS	'87→'90	ISON163	10,51	1200 R	1200 CL	'02→'04	ISON163	10,51
1000 K	100 LT	'86→'91	ISON163	10,51	1200 R	1200 GS	'04→'10	ISON164	10,43
1000 K	100 LT ABS	'86→'91	ISON163	10,51	1200 R	1200 GS	'11→'18	ISON160	10,43
1000 K	100 RS	'83→'92	ISON163	10,51	1200 R	1200 GS Adventure	'06→'13	ISON164	10,43
1000 K	100 RS ABS	'83→'92	ISON163	10,51	1200 R	1200 GS Adventure	'14→'18	ISON160	10,43
1000 K	100 RT	'83→'89	ISON163	10,51	1200 R	1200 GS Rallye	'12→'12	ISON164	10,43
1000 K	100 RT ABS	'83→'89	ISON163	10,51	1200 R	1200 GS Rallye	'17→'18	ISON160	10,43
1000 R	100 /7	'76→'77	ISON161	6,39	1200 R	1200 R	'06→'13	ISON164	10,43
1000 R	100 /7T	'77→'84	ISON161	6,39	1200 R	1200 R	'14→'18	ISON160	10,43
1000 R	100 RS	'76→'84	ISON161	6,39	1200 R	1200 R Classic	'11→'12	ISON164	10,43
1000 R	100 RT	'78→'84	ISON161	6,39	1200 R	1200 RS	'15→'18	ISON160	10,43
1000 R	100 S	'76→'80	ISON161	6,39	1200 R	1200 RT	'05→'13	ISON164	10,43
1000 S	1000 R (K47 - forg. wheels)	'17→'20	ISON160	10,43	1200 R	1200 RT	'14→'18	ISON160	10,43
1000 S	1000 R (K47)	'13→'20	ISON160	10,43	1200 R	1200 S	'05→'08	ISON164	10,43
1000 S	1000 RR (K46 - forg. wheels)	'15→'18	ISON160	10,43	1200 R	1200 ST	'03→'08	ISON164	10,43
1000 S	1000 RR (K46)	'09→'18	ISON160	10,43	1250 R	1250 GS	'19→'20	ISON160	10,43
1000 S	1000 RR (K67)	'19→'20	ISON160	10,43	1250 R	1250 GS Adventure	'19→'20	ISON160	10,43
1000 S	1000 XR (K49)	'15→'19	ISON160	10,43	1250 R	1250 R	'19→'20	ISON160	10,43
1000 S	1000 XR (K69)	'20→'20	ISON160	10,43	1250 R	1250 RS	'19→'20	ISON160	10,43
1100 K	1100 LT	'89→'99	ISON163	10,51	1250 R	1250 RT	'19→'20	ISON160	10,43
1100 K	1100 LT ABS	'93→'99	ISON163	10,51	1250 R	1250 RT Sport	'19→'20	ISON160	10,43
1100 K	1100 RS	'92→'96	ISON163	10,51	1300 K	1300 GT	'09→'11	ISON160	10,43
1100 K	1100 RS ABS	'92→'96	ISON163	10,51	1300 K	1300 R	'07→'12	ISON160	10,43
1100 R	1100 GS	'93→'99	ISON163	10,51	1300 K	1300 S	'07→'16	ISON160	10,43
1100 R	1100 GS ABS	'93→'99	ISON163	10,51	1600 K	1600 Bagger	'17→'20	ISON164	10,43
1100 R	1100 R	'93→'01	ISON163	10,51	1600 K	1600 Grand America	'18→'20	ISON164	10,43
1100 R	1100 RS	'92→'01	ISON163	10,51					



FILTRI ISON / ISON FILTER

CC	Modello Model	Anno Years	Codice Code	€
1600	K 1600 GT	'11→'20	ISON164	10,43
1600	K 1600 GTL	'11→'20	ISON164	10,43
1600	K 1600 GTL Exclusive	'13→'20	ISON164	10,43

BOMBARDIER-CAN AM

400	EFI Outlander	'09→'14	ISON152	8,34
400	STD Outlander	'07→'09	ISON152	8,34
400	STD Outlander Max	'07→'14	ISON152	8,34
400	XT Outlander	'07→'14	ISON152	8,34
400	XT Outlander Max	'07→'13	ISON152	8,34
500	Outlander	'13→'14	ISON152	8,34
500	Outlander Max	'13→'14	ISON152	8,34
500	Renegade	'07→'15	ISON152	8,34
500	STD Outlander	'07→'14	ISON152	8,34
500	STD Outlander Max	'07→'12	ISON152	8,34
500	XT Outlander	'07→'14	ISON152	8,34
500	XT Outlander Max	'07→'14	ISON152	8,34
650	DS	'00	ISON151	6,42
650	DS X Baja	'07	ISON152	8,34
650	Outlander	'13→'15	ISON152	8,34
650	Outlander Max	'13→'14	ISON152	8,34
650	STD Outlander	'07→'12	ISON152	8,34
650	STD Outlander Max	'07→'12	ISON152	8,34
650	XT Outlander	'07→'12	ISON152	8,34
650	XT Outlander Max	'07→'12	ISON152	8,34
800	EFI Renegade	'07→'08	ISON152	8,34
800	LTD Outlander Max	'07→'12	ISON152	8,34
800	R Commander	'11→'15	ISON152	8,34
800	R EFI Outlander	'09→'12	ISON152	8,34
800	R EFI Renegade	'09→'11	ISON152	8,34
800	R Outlander	'12→'15	ISON152	8,34
800	R Outlander 4X4 DPS	'13	ISON152	8,34
800	R Outlander DPS	'13	ISON152	8,34
800	R Outlander MAX	'13→'14	ISON152	8,34
800	R Renegade	'12→'15	ISON152	8,34
800	R X Renegade	'09→'10	ISON152	8,34
800	R XMR Outlander	'11→'12	ISON152	8,34
800	R XT Outlander	'09→'14	ISON152	8,34
800	R XT Outlander Max	'09→'12	ISON152	8,34
800	R XXC Outlander	'11	ISON152	8,34
800	R XXC Renegade	'11→'14	ISON152	8,34
800	STD Outlander	'07→'08	ISON152	8,34
800	STD Outlander Max	'07→'12	ISON152	8,34
800	X EFI Renegade	'08→'08	ISON152	8,34
800	XT Outlander	'07→'08	ISON152	8,34
800	XT Outlander Max	'07→'08	ISON152	8,34
1000	Commander	'11→'15	ISON152	8,34
1000	Commander Max	'14→'14	ISON152	8,34
1000	DPS Commander	'13→'15	ISON152	8,34
1000	LTD Commander	'12→'15	ISON152	8,34
1000	Maverick Max	'14→'15	ISON152	8,34
1000	Outlander	'12→'14	ISON152	8,34
1000	Outlander 4X4	'13→'14	ISON152	8,34
1000	Outlander Max	'13	ISON152	8,34
1000	R Maverick	'14	ISON152	8,34
1000	Renegade	'12→'14	ISON152	8,34
1000	X Commander	'11→'13	ISON152	8,34
1000	XT Commander	'11→'15	ISON152	8,34
1000	XT Outlander	'13→'14	ISON152	8,34
1000	XT-P Commander	'14→'15	ISON152	8,34
1000	XXC Renegade	'12→'14	ISON152	8,34

CC	Modello Model	Anno Years	Codice Code	€
BUELL				
1200	M2 Cyclone	'94→'02	ISON171B	9,67
1200	S1 Lightning	'94→'00	ISON171B	9,67
1200	S1 White Lightning	'98→'99	ISON171B	9,67
1200	S2 Thunderbolt	'94→'95	ISON171B	9,67
1200	S2T Thunderbolt	'95→'96	ISON171B	9,67
1200	S3 Thunderbolt	'97→'00	ISON171B	9,67
1200	S3T Thunderbolt	'97→'02	ISON171B	9,67
1200	X1 Lightning	'98→'02	ISON171B	9,67

CAGIVA

350	Alazzurra	'85→'88	ISON153	8,87
350	Alazzurra GT	'84→'86	ISON153	8,87
350	Alazzurra TL	'84→'86	ISON153	8,87
650	Alazzurra	'85→'88	ISON153	8,87
650	Alazzurra GT	'87→'88	ISON153	8,87
650	Raptor	'01→'05	ISON138	8,06
650	Raptor IE	'06→'07	ISON138	8,06
650	V-Raptor	'05→'07	ISON138	8,06
750	Elefant	'93→'97	ISON153	8,87
900	Elefant C	'93→'97	ISON153	8,87
900	Elefant GT IE	'91→'92	ISON153	8,87
900	Gran Canyon IE	'98→'00	ISON153	8,87
1000	Navigator	'00→'05	ISON138	8,06
1000	Raptor	'00→'05	ISON138	8,06
1000	V-Raptor	'00→'05	ISON138	8,06
1000	X-TRA Raptor	'00→'05	ISON138	8,06

CCM

404	404 DS	'03→'04	ISON139	4,26
404	404 DS Supermoto	'03→'04	ISON139	4,26
404	404 DS Supermoto	'07→'09	ISON139	4,26
404	404 DS TRAIL	'07→'09	ISON139	4,26
404	404 E	'03→'04	ISON139	4,26
604	E DS Dual Sport/Trail	'98→'03	ISON151	6,42
604	E Supermoto	'99→'03	ISON151	6,42
604	RS Roadster	'00→'03	ISON151	6,42
644	DS	'04→'04	ISON137	4,96
644	DS Supermoto	'04→'04	ISON137	4,96
644	R 30	'02→'04	ISON137	4,96

DERBI

125	Boulevard	'03→'12	ISON183	5,39
125	Boulevard S	'07→'07	ISON183	5,39
125	DRD R Senda	'10→'13	ISON563	8,31
125	DRD SM Senda	'09→'14	ISON563	8,31
125	DRD SM Senda	'13→'14	ISON563	8,31
125	GP1 Racing	'07→'09	ISON183	5,39
125	GP1	'06→'09	ISON183	5,39
125	GPR 4V	'09→'16	ISON563	8,31
125	Mulhacen	'07→'07	ISON563	8,31
125	Mulhacen	'07→'07	ISON563	8,31
125	Mulhacen	'08→'10	ISON563	8,31
125	Mulhacen Cafe	'08→'11	ISON563	8,31
125	Rambla	'08→'12	ISON183	5,39
125	Sonar	'10	ISON183	5,39
125	Terra Adventure	'07→'14	ISON563	8,31
125	Terra Euro	'07→'13	ISON563	8,31
150	Boulevard	'03→'07	ISON183	5,39
150	Sonar	'09→'10	ISON183	5,39



FILTRI ISON / ISON FILTER

CC	Modello Model	Anno Years	Codice Code	€
200	Boulevard	'05→'05	ISON183	5,39
250	GP1 I Racing	'07→'09	ISON183	5,39
250	GP1	'06→'07	ISON183	5,39
250	Rambla I	'08→'09	ISON183	5,39
300	Rambla I	'10→'12	ISON183	5,39
659	Mulhacén	'06→'08	ISON145	4,77

DUCATI

350	F3	'87→'88	ISON153	8,87
350	Indiana	'87→'88	ISON153	8,87
400	Monster	'95→'97	ISON153	8,87
400	Monster	'02→'04	ISON153	8,87
400	Monster (Japan)	'07→'08	ISON153	8,87
400	Monster Dark	'05→'05	ISON153	8,87
400	Scrambler Sixty 2	'17→'20	ISON153	8,87
400	Supersport	'93→'97	ISON153	8,87
550	Supermono	'93→'95	ISON153	8,87
600	Monster	'93→'97	ISON153	8,87
600	Monster	'93→'01	ISON153	8,87
600	Monster	'93→'01	ISON153	8,87
600	Monster City	'98→'01	ISON153	8,87
600	Monster Dark	'98→'01	ISON153	8,87
600	Monster Dark City	'98→'01	ISON153	8,87
600	Pantah	'81→'82	ISON153	8,87
600	Supersport	'91→'98	ISON153	8,87
620	Monster (1A serie)	'02→'05	ISON153	8,87
620	MONSTER (2A serie)	'05→'06	ISON153	8,87
620	Monster Dark (1A serie)	'03→'05	ISON153	8,87
620	Monster Dark (2A serie)	'05→'06	ISON153	8,87
620	Multistrada	'05→'06	ISON153	8,87
620	Multistrada Dark	'05→'06	ISON153	8,87
620	Supersport S	'03	ISON153	8,87
650	Indiana	'87→'90	ISON153	8,87
695	Monster	'06→'08	ISON153	8,87
696	Monster	'08→'13	ISON153	8,87
696	Monster +	'09→'14	ISON153	8,87
696	Monster + ABS	'09→'14	ISON153	8,87
696	Monster ABS	'08→'13	ISON153	8,87
696	Monster Anniversary + ABS	'13→'13	ISON153	8,87
748	748	'95→'02	ISON153	8,87
748	748 R	'00→'02	ISON153	8,87
748	748 S	'00→'02	ISON153	8,87
748	748 SP	'95→'99	ISON153	8,87
748	748 SPS	'98→'99	ISON153	8,87
748	748 Testa Bassa	'01→'01	ISON153	8,87
749	749	'03→'07	ISON153	8,87
749	749 Dark	'05→'06	ISON153	8,87
749	749 R	'03→'07	ISON153	8,87
749	749 S	'03→'07	ISON153	8,87
750	F1	'85→'88	ISON153	8,87
750	Indiana	'87→'90	ISON153	8,87
750	Monster (Bidisco)	'96→'02	ISON153	8,87
750	Monster (Monodisco)	'96→'97	ISON153	8,87
750	Monster City	'99	ISON153	8,87
750	Monster City Dark	'99	ISON153	8,87
750	Monster Dark	'99→'02	ISON153	8,87
750	Paso	'87→'88	ISON153	8,87
750	Sport	'88→'90	ISON153	8,87
750	Sport IE	'01→'02	ISON153	8,87
750	SS	'91→'98	ISON153	8,87
750	Supersport IE	'99→'02	ISON153	8,87
795	Monster	'12→'15	ISON153	8,87
795	Monster ABS	'13→'15	ISON153	8,87

CC	Modello Model	Anno Years	Codice Code	€
795	Monster ABS Corse Stripe	'14→'15	ISON153	8,87
796	Hypermotard	'10→'12	ISON153	8,87
796	Monster	'10→'13	ISON153	8,87
796	Monster ABS	'10→'14	ISON153	8,87
796	Monster ABS Anniversary	'13	ISON153	8,87
797	Monster	'17→'19	ISON153	8,87
797	Monster +	'17→'19	ISON153	8,87
800	Monster	'03→'04	ISON153	8,87
800	Monster Dark	'03→'03	ISON153	8,87
800	Monster S	'03→'04	ISON153	8,87
800	Monster S2R	'05→'07	ISON153	8,87
800	Monster S2R Dark	'05→'06	ISON153	8,87
800	Supersport	'03→'05	ISON153	8,87
800	Supersport S	'03→'03	ISON153	8,87
803	Scrambler Cafe' Racer	'17→'20	ISON153	8,87
803	Scrambler Classic	'15→'18	ISON153	8,87
803	Scrambler Desert Sled	'17→'20	ISON153	8,87
803	Scrambler Flat Track PRO	'16	ISON153	8,87
803	Scrambler Full Throttle	'15→'20	ISON153	8,87
803	Scrambler Icon	'15→'20	ISON153	8,87
803	Scrambler Mach 2.0	'18	ISON153	8,87
803	Scrambler SCR	'20	ISON153	8,87
803	Scrambler Street Classic	'18	ISON153	8,87
803	Scrambler Urban Enduro	'15→'16	ISON153	8,87
821	Hypermotard	'13→'15	ISON153	8,87
821	Hypermotard SP	'13→'15	ISON153	8,87
821	Hyperstrada	'13→'15	ISON153	8,87
821	Monster	'14→'20	ISON153	8,87
821	Monster Dark	'15→'18	ISON153	8,87
821	Monster Stealth	'19→'20	ISON153	8,87
821	Monster Stripe	'15→'18	ISON153	8,87
848	848	'07→'13	ISON153	8,87
848	848 EVO	'10→'13	ISON153	8,87
848	848 EVO Corse Special Edition	'11→'13	ISON153	8,87
848	Streetfighter	'11→'15	ISON153	8,87
851	851 SP	'88→'89	ISON153	8,87
851	851 SP	'91	ISON153	8,87
851	851 SP2	'90	ISON153	8,87
851	851 SP4	'92→'92	ISON153	8,87
851	851 Sport	'88→'91	ISON153	8,87
851	851 Strada	'92→'94	ISON153	8,87
888	888 Superbike Strada SP	'92→'95	ISON153	8,87
888	888 Superbike Strada SP4	'92	ISON153	8,87
900	MH IE Evoluzione	'01→'02	ISON153	8,87
900	Monster	'93→'99	ISON153	8,87
900	Monster City	'99	ISON153	8,87
900	Monster City Dark	'99	ISON153	8,87
900	Monster City Dark IE	'00→'02	ISON153	8,87
900	Monster City IE	'00→'02	ISON153	8,87
900	Monster Cromo	'99	ISON153	8,87
900	Monster Cromo IE	'00→'02	ISON153	8,87
900	Monster Dark	'99	ISON153	8,87
900	Monster Dark IE	'00→'02	ISON153	8,87
900	Monster IE	'99→'02	ISON153	8,87
900	Monster Metallic IE	'00→'01	ISON153	8,87
900	Monster S	'98→'99	ISON153	8,87
900	Monster S IE	'00→'02	ISON153	8,87
900	Sport IE	'02→'02	ISON153	8,87
900	SS Super Light	'92→'96	ISON153	8,87
900	Supersport	'89→'97	ISON153	8,87
900	Supersport FE	'97→'98	ISON153	8,87
900	Supersport IE	'98→'02	ISON153	8,87
906	Paso	'88→'91	ISON153	8,87



FILTRI ISON / ISON FILTER

CC	Modello Model	Anno Years	Codice Code	€	CC	Modello Model	Anno Years	Codice Code	€
907	907 IE	'90→'93	ISON153	8,87	1100	Hypermotard S	'07→'09	ISON153	8,87
916	916	'94→'98	ISON153	8,87	1100	Monster	'09→'10	ISON153	8,87
916	916 S	'94	ISON153	8,87	1100	Monster ABS	'10	ISON153	8,87
916	916 Senna	'95→'98	ISON153	8,87	1100	Monster Diesel	'13	ISON153	8,87
916	916 SP	'94→'95	ISON153	8,87	1100	Monster EVO ABS	'11→'13	ISON153	8,87
916	916 SP III	'96	ISON153	8,87	1100	Monster EVO Anniversary	'13	ISON153	8,87
916	Monster S4	'01→'03	ISON153	8,87	1100	Monster S	'09→'10	ISON153	8,87
916	Monster S4 Foggy	'02	ISON153	8,87	1100	Monster S ABS	'10	ISON153	8,87
916	ST4	'99→'03	ISON153	8,87	1100	Multistrada	'07→'09	ISON153	8,87
939	Hypermotard	'16→'18	ISON153	8,87	1100	Multistrada S	'07→'09	ISON153	8,87
939	Hypermotard SP	'16→'18	ISON153	8,87	1100	Scrambler	'18→'20	ISON153	8,87
939	Hyperstrada	'16→'18	ISON153	8,87	1100	Scrambler Special	'18→'20	ISON153	8,87
939	Supersport	'17→'19	ISON153	8,87	1100	Scrambler Sport	'18→'20	ISON153	8,87
939	Supersport S	'17→'19	ISON153	8,87	1100	Streetfighter	'09→'11	ISON153	8,87
944	ST2	'97→'03	ISON153	8,87	1100	Streetfighter S	'09→'13	ISON153	8,87
950	Hypermotard	'19→'20	ISON153	8,87	1103	Streetfighter V4	'20→'20	ISON158	6,73
950	Hypermotard SP	'19→'20	ISON153	8,87	1103	Streetfighter V4 S	'20→'20	ISON158	6,73
950	Multistrada	'17→'20	ISON153	8,87	1198	1198	'09→'12	ISON153	8,87
950	Multistrada S	'19→'20	ISON153	8,87	1198	1098 R	'07→'11	ISON153	8,87
955	Panigale V2	'20	ISON158	6,73	1198	1098 R Bayliss	'09→'11	ISON153	8,87
990	Desmodesicci RR	'07→'09	ISON153	8,87	1198	1198 R Corse Special Edition	'10→'12	ISON153	8,87
992	ST3	'04→'07	ISON153	8,87	1198	1198 S	'08→'12	ISON153	8,87
992	ST3 ABS	'06→'07	ISON153	8,87	1198	1198 S Corse Special Edition	'10→'12	ISON153	8,87
992	ST3 S ABS	'06→'07	ISON153	8,87	1198	1198 SP	'11→'12	ISON153	8,87
996	996	'99→'01	ISON153	8,87	1200	Diavel	'11→'18	ISON153	8,87
996	916 SPS	'97→'98	ISON153	8,87	1200	Diavel AMG	'12→'13	ISON153	8,87
996	996 S	'01→'01	ISON153	8,87	1200	Diavel Carbon	'11→'18	ISON153	8,87
996	996 SPS	'99→'00	ISON153	8,87	1200	Diavel Cromo	'12→'12	ISON153	8,87
996	Monster S4R	'03→'06	ISON153	8,87	1200	Diavel Dark	'12→'13	ISON153	8,87
996	ST4 S	'01→'05	ISON153	8,87	1200	Diavel Diesel	'17→'18	ISON153	8,87
996	ST4 S ABS	'03→'05	ISON153	8,87	1200	Diavel Strada	'13→'14	ISON153	8,87
998	998	'02→'03	ISON153	8,87	1200	Diavel Titanium	'15→'15	ISON153	8,87
998	996 R	'01→'01	ISON153	8,87	1200	Monster	'14→'20	ISON153	8,87
998	998 FE	'03→'04	ISON153	8,87	1200	Monster 25° Aniversary	'19	ISON153	8,87
998	998 Matrix	'03→'04	ISON153	8,87	1200	Monster R	'16→'19	ISON153	8,87
998	998 R	'02	ISON153	8,87	1200	Monster S	'14→'20	ISON153	8,87
998	998 S	'02→'04	ISON153	8,87	1200	Monster S Stripe	'15→'16	ISON153	8,87
998	998 S Bayliss/Bostrom	'02	ISON153	8,87	1200	Multistrada	'10→'12	ISON153	8,87
998	Monster S4R Testastretta	'07→'08	ISON153	8,87	1200	Multistrada ABS	'10→'17	ISON153	8,87
998	Monster S4RS Testastretta	'06→'08	ISON153	8,87	1200	Multistrada Enduro	'16→'18	ISON153	8,87
999	999	'03→'06	ISON153	8,87	1200	Multistrada Enduro PRO	'17→'19	ISON153	8,87
999	999 R	'03→'06	ISON153	8,87	1200	Multistrada Enduro Touring	'16→'18	ISON153	8,87
999	999 R Xerox	'06	ISON153	8,87	1200	Multistrada Pikes Peak	'16→'17	ISON153	8,87
999	999 S	'03→'06	ISON153	8,87	1200	Multistrada S	'15→'17	ISON153	8,87
1000	Monster	'03	ISON153	8,87	1200	Multistrada S D-AIR	'15→'17	ISON153	8,87
1000	Monster S	'03→'05	ISON153	8,87	1200	Multistrada S Granturismo	'13→'14	ISON153	8,87
1000	Monster S2R	'06→'08	ISON153	8,87	1200	Multistrada S Pikes Peak	'12→'14	ISON153	8,87
1000	Multistrada DS	'03→'06	ISON153	8,87	1200	Multistrada S Sport	'10→'12	ISON153	8,87
1000	Multistrada S DS	'03→'06	ISON153	8,87	1200	Multistrada S Touring	'10→'14	ISON153	8,87
1000	Paul Smart LE	'06→'08	ISON153	8,87	1200	Multistrada S Touring D-AIR	'14	ISON153	8,87
1000	Sportclassic	'06→'08	ISON153	8,87	1260	Diavel	'19→'20	ISON153	8,87
1000	Sportclassic GT	'06→'12	ISON153	8,87	1260	Diavel S	'19→'20	ISON153	8,87
1000	Sportclassic Gt Touring	'06→'12	ISON153	8,87	1260	Multistrada	'18→'20	ISON153	8,87
1000	Sportclassic S	'06→'11	ISON153	8,87	1260	Multistrada Enduro	'19→'20	ISON153	8,87
1000	Supersport	'03→'06	ISON153	8,87	1260	Multistrada S	'18→'20	ISON153	8,87
1000	Supersport DS	'04→'06	ISON153	8,87	1260	Multistrada S D-Air	'18→'20	ISON153	8,87
1098	1098	'06→'09	ISON153	8,87	1260	Multistrada S Grand Tour	'20	ISON153	8,87
1098	1098 S	'06→'11	ISON153	8,87	1260	Multistrada S Pikes Peak	'18→'20	ISON153	8,87
1098	1098 S Tricolore	'07→'07	ISON153	8,87	1262	XDiavel	'16→'20	ISON153	8,87
1100	Hypermotard	'07→'09	ISON153	8,87	1262	XDiavel S	'16→'20	ISON153	8,87
1100	Hypermotard EVO	'10→'12	ISON153	8,87					
1100	Hypermotard EVO SP	'10→'12	ISON153	8,87					



FILTRI ISON / ISON FILTER

CC	Modello Model	Anno Years	Codice Code	€
----	------------------	---------------	----------------	---

FANTIC MOTOR

125	Caballero Motard	'08→'13	ISON141	5,56
125	Cab. Motard Casa e Comp.	'11→'15	ISON141	5,56
125	Caballero R	'08→'13	ISON141	5,56
125	Caballero R Competition	'08→'13	ISON141	5,56
125	Caballero R Enduro	'08→'13	ISON141	5,56
125	Caballero Regolarità Casa	'11→'15	ISON141	5,56
125	Caballero Regolarità Competiz.	'07→'09	ISON141	5,56
125	Caballero Regolarità Competiz.	'11→'15	ISON141	5,56
125	Caballero Supersei Motard	'07→'09	ISON141	5,56
200	Caballero Motard	'09→'15	ISON141	5,56
200	Caballero Regolarità	'09→'15	ISON141	5,56
250	EC F 4T	'10→'13	ISON141	5,56
250	EC F SIX Days	'12	ISON141	5,56
250	TF ES	'11→'13	ISON141	5,56

GAS GAS

250	EC F	'10→'15	ISON141	5,56
250	EC F Cami	'14→'15	ISON141	5,56
300	EC F	'13→'15	ISON141	5,56
450	EC F	'13→'15	ISON141	5,56
450	EC FSE Enduro	'03→'09	ISON112	3,34
450	EC FSR	'05→'09	ISON112	3,34
450	HP Wild Quad	'04→'09	ISON112	3,34
450	Pampera	'07→'08	ISON112	3,34
450	SM FSE Supermotard	'03	ISON112	3,34
450	SM FSR Supermotard	'07→'09	ISON112	3,34
515	EC FSE	'05→'09	ISON112	3,34
515	EC FSR	'05→'09	ISON112	3,34
515	HP Wild Quad	'09→'09	ISON112	3,34
515	SM FSR	'07→'09	ISON112	3,34

GILERA

125	Arcore	'75→'79	ISON153	8,87
125	DNA	'01→'03	ISON183	5,39
125	Nexus	'07→'08	ISON183	5,39
125	Nexus IE	'08→'11	ISON183	5,39
125	Runner VX	'01→'13	ISON183	5,39
125	Runner VX ST	'08→'13	ISON183	5,39
150	Arcore	'72→'75	ISON153	8,87
180	DNA	'01→'03	ISON183	5,39
180	Runner VXR	'01→'04	ISON183	5,39
200	Runner VX	'05→'11	ISON183	5,39
200	Runner VXR	'02→'06	ISON183	5,39
250	Nexus IE	'06→'07	ISON183	5,39
250	Nexus IE SP	'06→'07	ISON183	5,39
250	Oregon	'07→'08	ISON183	5,39
300	Nexus IE	'08→'12	ISON183	5,39
500	Fuoco IE	'07→'13	ISON184	6,41
500	Fuoco IE LT	'13→'15	ISON184	6,41
500	Nexus	'03→'10	ISON184	6,41
500	Nexus IE	'10→'12	ISON184	6,41
500	Nexus SP	'06→'07	ISON184	6,41
800	GP	'08→'14	ISON565	9,47

HARLEY DAVIDSON

883	XL 53 C Sportster Custom	'00→'03	ISON170B	8,56
883	XL 883 C Sportster Custom	'99→'09	ISON171B	9,67
883	XL 883 DLX Sportster Deluxe	'90→'95	ISON170B	8,56
883	XL 883 HUG Sportster Hugger	'90→'98	ISON170B	8,56

CC	Modello Model	Anno Years	Codice Code	€
----	------------------	---------------	----------------	---

883	XL 883 HUG Sportster Hugger	'99→'03	ISON171B	9,67
883	XL 883 L Sportster	'06→'09	ISON171B	9,67
883	XI 883 L Sportster Low	'05	ISON171B	9,67
883	XL 883 L Sportster Low	'10	ISON171B	9,67
883	XL 883 L Sportster Superlow	'11→'19	ISON171B	9,67
883	XL 883 N Sportster Iron	'09→'20	ISON171B	9,67
883	XL 883 R Sportster R	'02→'10	ISON171B	9,67
883	XL 883 R Sportster Roadster	'10→'13	ISON170B	8,56
883	XL 883 Sportster	'04→'08	ISON171B	9,67
883	XLH 883 DLX Sportster Deluxe	'88→'89	ISON170B	8,56
883	XLH 883 DLX Sportster Deluxe	'90→'95	ISON170B	8,56
883	XLH 883 HUG Sport. Hugger	'88→'89	ISON170B	8,56
883	XLH 883 HUG Sport. Hugger	'90→'98	ISON170B	8,56
883	XLH 883 HUG Sport. Hugger	'99→'03	ISON171B	9,67
883	XLH 883 R Sportster Flat Track	'00→'03	ISON170B	8,56
883	XLH 883 Sportster	'86→'90	ISON170B	8,56
883	XLH 883 Sportster	'91→'92	ISON170B	8,56
883	XLH 883 Sportster	'93→'98	ISON170B	8,56
883	XLH 883 Sportster	'99→'03	ISON171B	9,67
1000	XLH Sportster	'85	ISON170B	8,56
1000	XLS Roadster	'85→'86	ISON170B	8,56
1000	XR	'84→'85	ISON170B	8,56
1100	XLH Sportster	'86→'87	ISON170B	8,56
1130	VRSCDX Night Rod Special	'13→'17	ISON171B	9,67
1200	Sportster	'86→'90	ISON170B	8,56
1200	Sportster	'91→'92	ISON170B	8,56
1200	XL 50 50th Anniversary Sportster	'07	ISON170B	8,56
1200	XL C Custom	'11	ISON171B	9,67
1200	XL C Sportster Custom	'96→'98	ISON170B	8,56
1200	XL C Sportster Custom	'99→'18	ISON171B	9,67
1200	XL CX Roadster	'16→'20	ISON171B	9,67
1200	XL L Sportster LOW	'06→'11	ISON171B	9,67
1200	XL N Sportster Nightster	'07→'08	ISON171B	9,67
1200	XL N Sportster Nightster	'07→'12	ISON171B	9,67
1200	XL NS Iron	'18→'20	ISON171B	9,67
1200	XL R Sportster Roadster	'04→'08	ISON171B	9,67
1200	XL S Sportster Sport	'96→'98	ISON170B	8,56
1200	XL S Sportster Sport	'00→'03	ISON171B	9,67
1200	XL T Superlow	'14→'18	ISON171B	9,67
1200	XL V Seventy Two	'12→'16	ISON171B	9,67
1200	XL X Forty Eight	'10→'20	ISON171B	9,67
1200	XL XS Forty Eight Special	'18→'19	ISON171B	9,67
1200	XLH Sportster	'88→'98	ISON170B	8,56
1200	XLH Sportster	'99→'03	ISON171B	9,67
1200	XR Sportster	'09→'10	ISON170B	8,56
1200	XR X Sportster	'10→'12	ISON170B	8,56
1250	VRSCF V-Rod Muscle	'13→'17	ISON171B	9,67
1340	FLHR Electra Glide Road King	'94	ISON170B	8,56
1340	FLHR Road King	'95→'99	ISON170B	8,56
1340	FLHRCI Road King	'96→'97	ISON170B	8,56
1340	FLHRCI Road King Classic	'94→'95	ISON170B	8,56
1340	FLHRCI Road King Classic	'98→'99	ISON170B	8,56
1340	FLHRI Road King	'96→'97	ISON170B	8,56
1340	FLHT Electra Glide	'86→'87	ISON170B	8,56
1340	FLHT Electra Glide Standard	'95→'98	ISON170B	8,56
1340	FLHTC Electra Glide Classic	'84→'85	ISON170B	8,56
1340	FLHTC Electra Glide Classic	'87→'98	ISON170B	8,56
1340	FLHTC Electra Glide Classic	'99→'03	ISON171B	9,67
1340	FLHTC El. Glide Cl. Liberty	'86→'86	ISON170B	8,56
1340	FLHTCI Electra Glide Classic	'96→'98	ISON170B	8,56
1340	FLHTCU Ultra Classic	'89→'97	ISON170B	8,56



FILTRI ISON / ISON FILTER

CC	Modello Model	Anno Years	Codice Code	€
	Electra Glide			
1340	FLHTCUI Ultra Classic	'95→'98	ISON170B	8,56
	Electra Glide			
1340	FLHTCUI Ultra Classic	'95→'95	ISON170B	8,56
	Electra Glide			
1340	FLHX Electra Glide Special	'84	ISON170B	8,56
1340	FLST Heritage Softail	'86→'90	ISON170B	8,56
1340	FLST Heritage Softail	'86	ISON170B	8,56
1340	FLST Heritage Softail	'87	ISON170B	8,56
1340	FLST Heritage Softail	'87	ISON170B	8,56
1340	FLST Heritage Softail	'88→'90	ISON170B	8,56
1340	FLSTC Heritage Softail Classic	'88→'98	ISON170B	8,56
1340	FLSTC Heritage Softail Classic	'88→'98	ISON170B	8,56
1340	FLSTF Fat Boy	'90→'98	ISON170B	8,56
1340	FLSTF Fat Boy	'91→'98	ISON170B	8,56
1340	FLSTN Heritage Softail Nost.	'93	ISON170B	8,56
1340	FLSTN Heritage Softail Nost	'93	ISON170B	8,56
1340	FLSTN Heritage Softail Special	'94→'96	ISON170B	8,56
1340	FLSTN Heritage Softail Special	'94→'96	ISON170B	8,56
1340	FLSTS Heritage Springer	'97→'98	ISON170B	8,56
1340	FLSTS Heritage Springer	'97→'98	ISON170B	8,56
1340	FLTC Tour Glide Classic	'84→'91	ISON170B	8,56
1340	FLTCU Ultra Classic Tour Glide	'89→'95	ISON170B	8,56
1340	FLTCUI Ultra Classic Tour Glide	'96	ISON170B	8,56
1340	FLTR Road Glide	'98	ISON170B	8,56
1340	FXD Dyna Super Glide	'95→'98	ISON173B	12,01
1340	FXD Dyna Super Glide	'96→'98	ISON173B	12,01
1340	FXDB Dyna Daytona	'92	ISON173B	12,01
1340	FXDB Sturgis	'91	ISON173B	12,01
1340	FXDC Dyna Glide Custom	'92	ISON173B	12,01
1340	FXDL Dyna Low Rider	'93→'98	ISON173B	12,01
1340	FXDL Dyna Low Rider	'93→'98	ISON173B	12,01
1340	FXDS Con Dyna Convertible	'95→'98	ISON173B	12,01
1340	FXDS Con Dyna Low Rider Convertible	'94	ISON173B	12,01
1340	FXDS Con Low Rider Conv.	'90→'93	ISON170B	8,56
1340	FXDWG Dyna Wide Glide	'93→'98	ISON173B	12,01
1340	FXDWG Dyna Wide Glide	'93→'98	ISON173B	12,01
1340	FXLR Low Rider Custom	'87→'94	ISON170B	8,56
1340	FXLR low rider custom	'87→'94	ISON170B	8,56
1340	FXLR Low Rider Custom	'87	ISON170B	8,56
1340	FXR Super Glide	'86→'94	ISON170B	8,56
1340	FXR Super Glide	'86	ISON170B	8,56
1340	FXR Super Glide	'87→'94	ISON170B	8,56
1340	FXR Super Glide	'87	ISON170B	8,56
1340	FXRC Low Glide	'85	ISON170B	8,56
1340	FXRC Low Rider Chrome	'87	ISON170B	8,56
1340	FXRD Grand Touring Ed.	'86	ISON170B	8,56
1340	FXRD Grand Touring Ed.	'86	ISON170B	8,56
1340	FXRDG Disc Glide	'84	ISON170B	8,56
1340	FXRS Low Glide	'84→'92	ISON170B	8,56
1340	FXRS Low Glide	'84→'86	ISON170B	8,56
1340	FXRS Low Rider	'87→'92	ISON170B	8,56
1340	FXRS Low Rider	'87→'87	ISON170B	8,56
1340	FXRS SP Low Rider Sport Ed.	'91→'93	ISON170B	8,56
1340	FXRT Sport Glide	'84→'92	ISON170B	8,56
1340	FXRT Sport Glide	'84→'86	ISON170B	8,56
1340	FXRT Sport Glide	'87→'91	ISON170B	8,56
1340	FXRT Sport Glide	'87	ISON170B	8,56
1340	FXST Softail	'84→'87	ISON170B	8,56
1340	FXST Softail	'84→'90	ISON170B	8,56
1340	FXST Softail	'87→'90	ISON170B	8,56

CC	Modello Model	Anno Years	Codice Code	€
1340	FXSTB Bad Boy	'95→'97	ISON170B	8,56
1340	FXSTB Bad Boy	'95→'97	ISON170B	8,56
1340	FXSTC Softail Custom	'86→'87	ISON170B	8,56
1340	FXSTC Softail Custom	'86→'99	ISON170B	8,56
1340	FXSTC Softail Custom	'87→'99	ISON170B	8,56
1340	FXSTS Springer Softail	'88	ISON170B	8,56
1340	FXSTS Springer Softail	'88	ISON170B	8,56
1340	FXSTSB Bad Boy	'95	ISON170B	8,56
1340	FXSTSB Bad Boy	'95	ISON170B	8,56
1450	FLHR Road King	'99→'06	ISON171B	9,67
1450	FLHRS Road King Custom	'04→'07	ISON171B	9,67
1450	FLHRSI Road King Custom	'04→'07	ISON171B	9,67
1450	FLHT Electra Glide Standard	'99→'07	ISON171B	9,67
1450	FLHTCUI Electra Glide Ultra Classic	'99→'06	ISON171B	9,67
1450	FLHTI Electra Glide Standard	'00→'07	ISON171B	9,67
1450	FLSTC Heritage Softail Classic	'99→'07	ISON171B	9,67
1450	FLSTCI Heritage Softail Classic	'00→'07	ISON171B	9,67
1450	FLSTF Fat Boy	'99→'06	ISON171B	9,67
1450	FLSTFI Fat Boy	'00→'06	ISON171B	9,67
1450	FLSTFI Fat Boy 15th Anniversary Edition	'05→'05	ISON171B	9,67
1450	FLSTI Heritage Softail	'06	ISON171B	9,67
1450	FLSTN Softail Deluxe	'05→'06	ISON171B	9,67
1450	FLSTNI Softail Deluxe	'05→'06	ISON171B	9,67
1450	FLSTS Heritage Springer	'99→'03	ISON171B	9,67
1450	FLSTSC Softail Springer Classic	'05→'06	ISON171B	9,67
1450	FLSTSCI Softail Springer Classic	'05→'06	ISON171B	9,67
1450	FLSTSI Heritage Springer	'01→'03	ISON171B	9,67
1450	FLTR Road Glide	'99→'07	ISON171B	9,67
1450	FLTRI Road Glide	'98→'98	ISON170B	8,56
1450	FLTRI Road Glide	'99→'07	ISON171B	9,67
1450	FXD Dyna Super Glide	'99→'05	ISON171B	9,67
1450	FXD Super Glide	'10	ISON171B	9,67
1450	FXDBI Dyna Street BoB	'07→'07	ISON171B	9,67
1450	FXDBI Street Bob	'06→'06	ISON171B	9,67
1450	FXDC Dyna Super Glide Custom	'05→'05	ISON171B	9,67
1450	FXDCI Dyna Super Glide Custom	'05→'07	ISON171B	9,67
1450	FXDI 35th Anniversary Super Glide	'06→'06	ISON171B	9,67
1450	FXDI Dyna Super Glide	'04→'07	ISON171B	9,67
1450	FXDI35 35th Anniversary Super Glide	'05→'05	ISON171B	9,67
1450	FXDL Dyna Low RideR	'99→'05	ISON171B	9,67
1450	FXDLI Dyna Low Rider	'04→'07	ISON171B	9,67
1450	FXDS Con Dyna Super Glide Convertible	'99→'00	ISON171B	9,67
1450	FXDWG Dyna Wide Glide	'99→'05	ISON171B	9,67
1450	FXDWGI Dyna Wide Glide	'04→'07	ISON171B	9,67
1450	FXDX Dyna Super Glide Sport	'99→'05	ISON171B	9,67
1450	FXDXI Dyna Super Glide Sport	'04→'05	ISON171B	9,67
1450	FXDXT Dyna Super Glide T-Sport	'01→'03	ISON171B	9,67
1450	FXST Softail Standard	'99→'05	ISON171B	9,67
1450	FXSTB Night Train	'99→'06	ISON171B	9,67
1450	FXSTB Night Train Softail	'06→'06	ISON171B	9,67
1450	FXSTBI Night Train	'00→'05	ISON171B	9,67
1450	FXSTBI Night Train Softail	'06→'06	ISON171B	9,67
1450	FXSTD Softail Deuce	'00→'07	ISON171B	9,67
1450	FXSTDI Softail Deuce	'00→'07	ISON171B	9,67
1450	FXSTI Softail Standard	'00→'07	ISON171B	9,67
1450	FXSTS Springer Softail	'99→'06	ISON171B	9,67



FILTRI ISON / ISON FILTER

CC	Modello Model	Anno Years	Codice Code	€
250	CRF R	'08→'09	ISON116	3,89
250	CRM X Supermoto	'07	ISON116	3,89
300	CRE F X	'08→'16	ISON116	3,89
450	CRE F	'02	ISON116	3,89
450	CRE F R Enduro	'04→'16	ISON116	3,89
450	CRE F Supermoto	'02→'03	ISON116	3,89
450	CRE F X	'04→'16	ISON116	3,89
450	CRE R Enduro	'02→'07	ISON116	3,89
450	CRF R	'04→'09	ISON116	3,89
450	CRM F Motard	'04→'06	ISON116	3,89
450	CRM F R Supermoto	'07→'08	ISON116	3,89
450	CRM F X Supermoto	'07→'09	ISON116	3,89
490	CRE F X	'07→'07	ISON116	3,89
490	CRM F X Supermoto	'07→'07	ISON116	3,89
500	CRE F X	'08→'16	ISON116	3,89
500	CRM F X	'11	ISON116	3,89

HONDA

125	VT C Shadow	'99→'08	ISON112	3,34
125	XL V Varadero	'00→'16	ISON112	3,34
150	CRF R	'07→'19	ISON116	3,89
150	CRF RB	'07→'19	ISON116	3,89
200	TRX D	'91→'97	ISON112	3,34
250	ATC ES	'85→'87	ISON112	3,34
250	CB N	'79→'81	ISON111	3,89
250	CB N D	'81→'82	ISON111	3,89
250	CB RS	'80→'83	ISON111	3,89
250	CB T	'78→'78	ISON111	3,89
250	CBF	'04→'06	ISON112	3,34
250	CBR F	'86→'86	ISON111	3,89
250	CBR R	'87→'89	ISON111	3,89
250	CBR R	'11→'13	ISON112	3,34
250	CBR R ABS	'11→'13	ISON112	3,34
250	CBR RR	'90→'94	ISON111	3,89
250	CBX RS	'84→'84	ISON112	3,34
250	CM	'83→'84	ISON111	3,89
250	CM C	'82→'85	ISON111	3,89
250	CM T	'81→'81	ISON111	3,89
250	CRF L	'12→'15	ISON116	3,89
250	CRF L ABS	'17→'20	ISON116	3,89
250	CRF M	'13→'14	ISON112	3,34
250	CRF M	'15→'16	ISON116	3,89
250	CRF R	'04→'04	ISON112	3,34
250	CRF R	'05→'20	ISON116	3,89
250	CRF Rally	'17	ISON116	3,89
250	CRF Rally ABS	'17→'20	ISON116	3,89
250	CRF RX	'19→'20	ISON116	3,89
250	CRF X	'04→'18	ISON116	3,89
250	NX	'87→'93	ISON112	3,34
250	NX 2	'90→'93	ISON112	3,34
250	NX AX-1	'89→'94	ISON112	3,34
250	TLR	'85→'85	ISON112	3,34
250	TRX	'85→'87	ISON112	3,34
250	TRX	'97→'99	ISON112	3,34
250	TRX R	'86→'89	ISON112	3,34
250	VT FL Spada	'88→'90	ISON111	3,89
250	XL R	'82→'87	ISON112	3,34
250	XL R	'90→'90	ISON112	3,34
250	XR	'00→'03	ISON112	3,34
250	XR Motard	'03→'05	ISON112	3,34
250	XR R	'82→'05	ISON112	3,34

CC	Modello Model	Anno Years	Codice Code	€
300	CB F ABS	'15→'16	ISON112	3,34
300	CBR R ABS	'14→'19	ISON112	3,34
300	Forza (NSS)	'13→'15	ISON204	8,06
300	Forza ABS (NSS A)	'13→'20	ISON204	8,06
300	SH i	'06→'14	ISON204	8,06
300	SH i ABS	'06→'20	ISON204	8,06
300	SH i Special	'13→'14	ISON204	8,06
300	SH i Sport	'06→'10	ISON204	8,06
300	SH i Sport ABS	'18→'19	ISON204	8,06
300	SH i Sporty	'13→'14	ISON204	8,06
300	TRX	'88→'00	ISON112	3,34
300	TRX EX	'93→'08	ISON112	3,34
300	TRX FW	'88→'00	ISON112	3,34
300	TRX X	'09→'09	ISON112	3,34
350	CB	'74	ISON401	5,81
350	CB F Four	'72→'75	ISON401	5,81
350	CB S	'86→'90	ISON111	3,89
350	Four CB F	'72→'75	ISON401	5,81
350	TRX	'86→'87	ISON112	3,34
350	TRX ES Rancher	'00→'03	ISON112	3,34
350	XL R	'84→'87	ISON112	3,34
350	XR R	'85→'87	ISON112	3,34
360	CJ T	'76→'78	ISON401	5,81
400	CB	'89→'90	ISON303	8,06
400	CB F	'75→'79	ISON401	5,81
400	CB N	'78→'83	ISON111	3,89
400	CB SF Super Four	'92→'96	ISON303	8,06
400	CB SF Super Four	'99→'05	ISON303	8,06
400	CB SF2 Super Four	'97→'97	ISON303	8,06
400	CB SF3 Super Four	'97→'97	ISON303	8,06
400	CB SS	'01→'05	ISON303	8,06
400	CB T	'78→'78	ISON111	3,89
400	CB-1	'89→'90	ISON303	8,06
400	CBR R	'86→'87	ISON202	6,67
400	CBX F,F2	'82→'83	ISON111	3,89
400	CM T	'79→'83	ISON111	3,89
400	NT Bros	'88→'88	ISON303	8,06
400	RVF R	'94→'96	ISON303	8,06
400	Silver Wing (FJS D)	'06→'08	ISON204	8,06
400	Silver Wing ABS (FJS A)	'06→'08	ISON204	8,06
400	SW-T (FJS D)	'09→'16	ISON204	8,06
400	SW-T ABS (FJS A)	'09→'16	ISON204	8,06
400	TRX EX	'99→'08	ISON112	3,34
400	TRX FA Fourtrax	'04→'07	ISON111	3,89
400	TRX FGA Fourtrax Rancher AT GSCAPE	'04→'07	ISON111	3,89
400	TRX FW	'95→'00	ISON112	3,34
400	TRX X	'09→'15	ISON112	3,34
400	VF F	'83→'85	ISON202	6,67
400	VFR R	'85→'86	ISON202	6,67
400	VFR R	'87→'92	ISON303	8,06
400	XR R	'96→'05	ISON112	3,34
420	TRX FE Fourtrax	'07→'11	ISON112	3,34
420	TRX FM Fourtrax Auto	'07→'11	ISON112	3,34
420	TRX FPA Fourtrax Auto	'09→'10	ISON112	3,34
420	TRX FPM Fourtrax	'09→'11	ISON112	3,34
420	TRX TE Fourtrax ES	'07→'09	ISON112	3,34
420	TRX TE Fourtrax Rancher ES	'07→'08	ISON112	3,34
420	TRX TM	'07→'11	ISON112	3,34
450	CB DX	'89→'92	ISON111	3,89
450	CB S	'86→'88	ISON111	3,89
450	CMX C Rebel	'87→'88	ISON111	3,89



FILTRI ISON / ISON FILTER

CC	Modello Model	Anno Years	Codice Code	€	CC	Modello Model	Anno Years	Codice Code	€
450	CRF L	'19→'20	ISON116	3,89	600	Silver Wing (FJS D)	'01→'05	ISON204	8,06
450	CRF R	'02→'20	ISON116	3,89	600	Silver Wing ABS (FJS A)	'05→'09	ISON204	8,06
450	CRF RX	'17→'20	ISON116	3,89	600	SW-T (FJS D)	'11→'16	ISON204	8,06
450	CRF X	'05→'16	ISON116	3,89	600	SW-T ABS (FJS A)	'12→'17	ISON204	8,06
450	TRX ES	'98→'01	ISON116	3,89	600	XL LM	'85→'87	ISON112	3,34
450	TRX R	'04→'14	ISON116	3,89	600	XL R	'83→'87	ISON112	3,34
500	CB	'75→'76	ISON401	5,81	600	XL RM	'86→'86	ISON112	3,34
500	CB	'94→'03	ISON303	8,06	600	XL V Transalp	'87→'00	ISON303	8,06
500	CB F	'77→'77	ISON401	5,81	600	XR R	'85→'91	ISON112	3,34
500	CB F	'13→'16	ISON204	8,06	600	XR R	'93→'00	ISON112	3,34
500	CB F ABS	'13→'20	ISON204	8,06	650	CB	'79→'81	ISON401	5,81
500	CB S	'98→'03	ISON303	8,06	650	CB C Custom	'80→'81	ISON401	5,81
500	CB T	'75→'77	ISON111	3,89	650	CB F	'14→'16	ISON204	8,06
500	CB X	'13→'15	ISON204	8,06	650	CB F ABS	'14→'19	ISON204	8,06
500	CB X ABS	'13→'20	ISON204	8,06	650	CB R NEO Sports Cafe	'19→'20	ISON204	8,06
500	CBF	'04→'07	ISON303	8,06	650	CB SC Custom	'82→'82	ISON401	5,81
500	CBF ABS	'04→'07	ISON303	8,06	650	CBR F	'14→'16	ISON204	8,06
500	CBR F	'87→'90	ISON303	8,06	650	CBR F ABS	'14→'20	ISON204	8,06
500	CBR R	'13→'15	ISON204	8,06	650	CBR R	'19→'20	ISON204	8,06
500	CBR R ABS	'13→'20	ISON204	8,06	650	CX E	'83	ISON111	3,89
500	CMX A	'17→'20	ISON204	8,06	650	CX T Turbo	'83	ISON111	3,89
500	CMX Rebel ABS	'17→'20	ISON204	8,06	650	FMX	'05→'08	ISON112	3,34
500	CX	'79→'81	ISON111	3,89	650	FX Vigor	'99→'03	ISON112	3,34
500	CX C	'80→'82	ISON111	3,89	650	GL D2	'84	ISON111	3,89
500	CX E	'82	ISON111	3,89	650	NT Bros	'88→'92	ISON303	8,06
500	CX TC Turbo	'82	ISON111	3,89	650	NT GT Hawk	'88→'91	ISON303	8,06
500	GL D Silver Wing	'82	ISON111	3,89	650	NT V Deauville	'98→'05	ISON303	8,06
500	TRX FA Fourtrax Foreman	'12	ISON111	3,89	650	NTV Revere	'88→'97	ISON303	8,06
500	TRX FA Fourtrax Foreman Auto	'01→'11	ISON111	3,89	650	NX Dominator	'88→'02	ISON112	3,34
500	TRX FE Fourtrax Foreman	'05→'09	ISON112	3,34	650	SLR	'97→'98	ISON112	3,34
500	TRX FM Fourtrax Foreman	'05→'09	ISON112	3,34	650	TRX FA Rincon	'03→'05	ISON111	3,89
500	TRX FM Fourtrax Foreman	'10→'10	ISON111	3,89	650	XL V Transalp	'00→'07	ISON303	8,06
500	TRX FPE Fourtrax Foreman	'08→'09	ISON112	3,34	650	XR L	'93→'19	ISON112	3,34
500	TRX FPE Fourtrax Foreman	'10→'10	ISON111	3,89	650	XR R	'00→'07	ISON112	3,34
500	TRX TM Fourtrax Foreman	'05→'06	ISON112	3,34	650	XR V Africa Twin	'88→'89	ISON303	8,06
500	VF F	'83→'84	ISON202	6,67	680	DN-01 ABS	'08→'11	ISON204	8,06
500	VF F2	'85→'87	ISON202	6,67	680	TRX FA Rubicon	'06→'14	ISON111	3,89
500	VT E	'83→'85	ISON202	6,67	700	CTX ABS DCT	'14→'16	ISON204	8,06
500	XBR	'85→'87	ISON112	3,34	700	CTX N ABS DCT	'14→'16	ISON204	8,06
500	XBR S	'86→'88	ISON112	3,34	700	NC Integra DCT ABS	'12→'14	ISON204	8,06
550	CB F/K	'77→'80	ISON401	5,81	700	NC S	'12→'14	ISON204	8,06
550	CBX F	'82→'83	ISON111	3,89	700	NC S ABS	'12→'14	ISON204	8,06
600	CB F Hornet	'98→'02	ISON303	8,06	700	NC S DCT ABS	'12→'14	ISON204	8,06
600	CB F Hornet	'03→'13	ISON204	8,06	700	NC X	'12→'14	ISON204	8,06
600	CB F Hornet ABS	'00→'04	ISON303	8,06	700	NC X ABS	'12→'14	ISON204	8,06
600	CB F Hornet ABS	'07→'13	ISON204	8,06	700	NC X DCT ABS	'12→'14	ISON204	8,06
600	CB F Hornet S	'99→'02	ISON303	8,06	700	NT V Deauville	'06→'13	ISON204	8,06
600	CB F Hornet S	'03→'04	ISON204	8,06	700	NT V Deauville ABS	'07→'15	ISON204	8,06
600	CBF N	'04→'12	ISON204	8,06	700	TRX XX	'08→'09	ISON112	3,34
600	CBF N ABS	'04→'12	ISON204	8,06	700	XL V Transalp	'08→'13	ISON204	8,06
600	CBF S	'04→'13	ISON204	8,06	700	XL V Transalp ABS	'08→'13	ISON204	8,06
600	CBF S ABS	'04→'13	ISON204	8,06	750	CB C Custom	'80→'81	ISON401	5,81
600	CBR F	'87→'00	ISON303	8,06	750	CB F	'76	ISON401	5,81
600	CBR F	'01→'07	ISON204	8,06	750	CB F	'79→'84	ISON401	5,81
600	CBR F	'11→'13	ISON204	8,06	750	CB F1	'77→'77	ISON401	5,81
600	CBR F ABS	'11→'13	ISON204	8,06	750	CB F2	'78→'78	ISON401	5,81
600	CBR F Sport	'01→'02	ISON204	8,06	750	CB F2 Seven Fifty	'92→'03	ISON303	8,06
600	CBR F4	'99→'00	ISON204	8,06	750	CB K	'69→'81	ISON401	5,81
600	CBR RR	'03→'16	ISON204	8,06	750	CB Nighthawk	'91→'03	ISON303	8,06
600	CBR RR ABS	'09→'16	ISON204	8,06	750	CBX F	'84→'87	ISON202	6,67
600	NTV Revere	'88→'92	ISON303	8,06	750	NC Integra DTC	'14→'20	ISON204	8,06
					750	NC Integra DTC S	'14→'20	ISON204	8,06



FILTRI ISON / ISON FILTER

CC	Modello Model	Anno Years	Codice Code	€	CC	Modello Model	Anno Years	Codice Code	€
750	NC J NM 4 Vultus	'15→'19	ISON204	8,06	954	CBR RR Fireblade	'02→'03	ISON204	8,06
750	NC S	'14	ISON204	8,06	1000	CB F Big One	'93→'97	ISON303	8,06
750	NC S ABS (35Kw)	'18→'20	ISON204	8,06	1000	CB R	'09→'15	ISON204	8,06
750	NC S ABS DCT	'16→'20	ISON204	8,06	1000	CB R ABS	'09→'20	ISON204	8,06
750	NC S ABS DCT (35Kw)	'18→'20	ISON204	8,06	1000	CB R+ ABS	'18→'20	ISON204	8,06
750	NC S DCT	'14→'15	ISON204	8,06	1000	CBF	'06→'12	ISON204	8,06
750	NC X	'14	ISON204	8,06	1000	CBF ABS	'06→'10	ISON204	8,06
750	NC X ABS	'14→'20	ISON204	8,06	1000	CBF F	'10→'15	ISON204	8,06
750	NC X ABS (35Kw)	'18→'20	ISON204	8,06	1000	CBF F ABS	'10→'16	ISON204	8,06
750	NC X ABS DCT	'14→'20	ISON204	8,06	1000	CBF FS ABS	'10→'13	ISON204	8,06
750	NC X ABS DCT (35Kw)	'18→'20	ISON204	8,06	1000	CBF FT ABS	'10→'13	ISON204	8,06
750	RVF RC45	'94→'98	ISON303	8,06	1000	CBF S ABS	'07→'11	ISON204	8,06
750	VF C	'87→'87	ISON202	6,67	1000	CBF ST ABS	'07→'15	ISON204	8,06
750	VF C	'93→'04	ISON303	8,06	1000	CBR F	'87→'99	ISON303	8,06
750	VF C Shadow	'83	ISON202	6,67	1000	CBR F	'93→'99	ISON303	8,06
750	VF C2	'97→'00	ISON303	8,06	1000	CBR RR	'04→'19	ISON204	8,06
750	VF CD	'95→'96	ISON303	8,06	1000	CBR RR ABS	'09→'16	ISON204	8,06
750	VF F Interceptor	'83→'85	ISON202	6,67	1000	CBR RR SP	'17→'19	ISON204	8,06
750	VF S Sabre	'82→'82	ISON202	6,67	1000	CBR RR SP ABS	'14→'16	ISON204	8,06
750	VFR F	'86→'87	ISON202	6,67	1000	CBR RR SP2	'17→'19	ISON204	8,06
750	VFR F	'88→'97	ISON303	8,06	1000	CBR RR-R	'20	ISON204	8,06
750	VFR R RC30	'88→'93	ISON303	8,06	1000	CBR RR-R SP	'20	ISON204	8,06
750	VT C	'10→'15	ISON204	8,06	1000	CBX	'79→'82	ISON401	5,81
750	VT C Shadow	'97→'07	ISON303	8,06	1000	CRF Africa Twin Abs	'16→'19	ISON204	8,06
750	VT C Shadow	'08	ISON204	8,06	1000	CRF Africa Twin Adventure Sport ABS	'18→'19	ISON204	8,06
750	VT C Shadow ABS	'04→'08	ISON204	8,06	1000	CRF Africa Twin Adventure Sport DCT ABS	'18→'19	ISON204	8,06
750	VT C Shadow ABS	'12→'14	ISON204	8,06	1000	CRF Africa Twin DCT ABS	'16→'19	ISON204	8,06
750	VT C Shadow Aero	'09	ISON204	8,06	1000	CRF Africa Twin Replica ABS	'17→'18	ISON204	8,06
750	VT C Shadow Aero ABS	'09	ISON204	8,06	1000	CRF Africa Twin Replica DCT ABS	'18→'18	ISON204	8,06
750	VT C2 Shadow	'97→'01	ISON303	8,06	1000	CRF L Africa Twin ABS	'16→'19	ISON204	8,06
750	VT C2 Shadow	'09→'14	ISON204	8,06	1000	CRF L Africa Twin Adventure Sport ABS	'18→'19	ISON204	8,06
750	VT C2 Shadow Spirit	'07→'08	ISON204	8,06	1000	CRF L Africa Twin Adventure Sport DCT ABS	'18→'19	ISON204	8,06
750	VT C2B Shadow	'09→'10	ISON204	8,06	1000	CRF L Africa Twin DCT ABS	'16→'19	ISON204	8,06
750	VT C2B Shadow Phantom	'11→'12	ISON204	8,06	1000	CRF L Africa Twin Replica ABS	'18	ISON204	8,06
750	VT C2B Shadow Spirit	'13→'16	ISON204	8,06	1000	CRF L Africa Twin Replica DCT ABS	'18	ISON204	8,06
750	VT C2S Shadow Spirit	'10→'14	ISON204	8,06	1000	GL Gold Wing	'75→'79	ISON401	5,81
750	VT CS Shadow	'10→'14	ISON204	8,06	1000	VF F	'84→'86	ISON202	6,67
750	VT DC Black Widow	'00→'04	ISON303	8,06	1000	VF R	'84→'86	ISON202	6,67
750	VT DC Shadow Spirit	'07	ISON303	8,06	1000	VTR F Firestorm	'97→'02	ISON303	8,06
750	VT DC Shadow Spirit	'08→'09	ISON204	8,06	1000	VTR F Firestorm	'03→'06	ISON204	8,06
750	VT S	'11→'11	ISON204	8,06	1000	VTR SP1	'00	ISON303	8,06
750	VT S VTRS	'10→'10	ISON204	8,06	1000	VTR SP1	'01	ISON204	8,06
750	VTC C Shadow Aero	'18→'19	ISON204	8,06	1000	VTR SP2	'02→'06	ISON204	8,06
750	VTC CS Shadow Aero ABS	'18→'20	ISON204	8,06	1000	XL V Varadero	'99→'02	ISON303	8,06
750	X-ADV	'17→'20	ISON204	8,06	1000	XL V Varadero	'03→'11	ISON204	8,06
750	XRV Africa Twin	'90→'03	ISON303	8,06	1000	XL V Varadero ABS	'04→'12	ISON204	8,06
800	PC Pacific Coast	'89→'98	ISON303	8,06	1100	CB ABS	'13→'15	ISON204	8,06
800	VFR	'02→'05	ISON204	8,06	1100	CB EX	'14→'16	ISON204	8,06
800	VFR ABS	'02→'05	ISON204	8,06	1100	CB EX ABS	'17→'20	ISON204	8,06
800	VFR F ABS	'14→'20	ISON204	8,06	1100	CB R	'80→'85	ISON401	5,81
800	VFR FI	'98→'01	ISON303	8,06	1100	CB RS ABS	'17→'20	ISON204	8,06
800	VFR FI	'02→'05	ISON204	8,06	1100	CB S ABS	'14	ISON204	8,06
800	VFR VTEC	'06→'09	ISON204	8,06	1100	CB SF X11	'00→'03	ISON303	8,06
800	VFR VTEC ABS	'06→'13	ISON204	8,06	1100	CBR XX Blackbird	'97→'08	ISON303	8,06
800	VFR X Crossrunner	'15→'15	ISON204	8,06	1100	CRF L Africa Twin ABS	'20	ISON204	8,06
800	VFR X Crossrunner ABS	'11→'20	ISON204	8,06	1100	CRF L Africa Twin Adventure	'20	ISON204	8,06
900	CB F	'82→'83	ISON401	5,81					
900	CB F Bol D'or	'79→'81	ISON401	5,81					
900	CB F Hornet	'02→'07	ISON204	8,06					
900	CBR Evolution Blade	'99	ISON303	8,06					
900	CBR RR Fireblade	'92→'99	ISON303	8,06					
929	CBR RR Fireblade	'00→'01	ISON204	8,06					



FILTRI ISON / ISON FILTER

CC	Modello Model	Anno Years	Codice Code	€
	Sport ABS			
1100	CRF L Africa Twin Adventure Sport DCT ABS	'20	ISON204	8,06
1100	CRF L Africa Twin DCT ABS	'20	ISON204	8,06
1100	GL	'80→'81	ISON401	5,81
1100	GL Gold Wing	'82	ISON401	5,81
1100	GL Gold Wing Aspencade	'83	ISON401	5,81
1100	ST Pan European	'90→'02	ISON303	8,06
1100	ST Pan European ABS	'92→'02	ISON303	8,06
1100	VT C Shadow	'87→'88	ISON202	6,67
1100	VT C Shadow	'89→'00	ISON303	8,06
1100	VT C2	'95→'05	ISON303	8,06
1100	VT C3	'98→'00	ISON303	8,06
1200	GL Gold Wing	'84→'86	ISON401	5,81
1200	VFR F ABS	'10→'16	ISON204	8,06
1200	VFR F DCT ABS	'10→'17	ISON204	8,06
1200	VFR X Crosstourer ABS	'12→'20	ISON204	8,06
1200	VFR X Crosstourer DCT ABS	'12→'20	ISON204	8,06
1200	VFR X Crosstourer Travel Edition DCT ABS	'13→'20	ISON204	8,06
1300	CB DC X4	'97→'00	ISON204	8,06
1300	CB F	'98→'01	ISON204	8,06
1300	CB F Superfour	'03→'09	ISON204	8,06
1300	CB N	'05→'12	ISON204	8,06
1300	CB N ABS	'05→'12	ISON204	8,06
1300	CB S	'05→'09	ISON204	8,06
1300	CB S ABS	'05→'13	ISON204	8,06
1300	CTX	'14→'14	ISON204	8,06
1300	CTX ABS	'14→'16	ISON204	8,06
1300	ST Pan European	'02→'09	ISON204	8,06
1300	ST Pan European ABS	'02→'16	ISON204	8,06
1300	VT CT ABS	'11→'13	ISON204	8,06
1300	VT CX	'10→'17	ISON204	8,06
1300	VT CX ABS	'10→'20	ISON204	8,06
1300	VTX S	'03→'08	ISON204	8,06
1500	GL A Aspencade	'91→'00	ISON303	8,06
1500	GL C F6C	'97→'03	ISON303	8,06
1500	GL Gold Wing	'88→'90	ISON303	8,06
1500	GL SE Gold Wing	'90→'00	ISON303	8,06
1800	GL Gold Wing ABS	'01→'20	ISON204	8,06
1800	GL Gold Wing Tour	'18→'20	ISON204	8,06
1800	GL Gold Wing Tour Airbag DCT	'19→'19	ISON204	8,06
1800	GL Gold Wing Tour DCT	'18→'20	ISON204	8,06
1800	GL Goldwing DCT	'20	ISON204	8,06
1800	GL Goldwing Tour	'20	ISON204	8,06
1800	GL Goldwing Tour Airbag DCT	'20	ISON204	8,06
1800	GL Goldwing Tour DCT	'20	ISON204	8,06
1800	GLF6BA B Gold Wing	'13→'19	ISON204	8,06
1800	GLF6CA C Gold Wing	'14→'17	ISON204	8,06
1800	VTX C	'02→'04	ISON204	8,06
1800	VTX C1	'05→'07	ISON204	8,06
1800	VTX F1	'08	ISON204	8,06

HUSABERG

250	FE E 4T	'13	ISON655	6,14
250	FE E 4T	'14	ISON652	6,01
350	FE E 4T	'13→'14	ISON652	6,01
390	FE E	'10→'12	ISON655	6,14
450	FC	'04→'07	ISON155	5,50
450	FE	'08→'14	ISON655	6,14
450	FE E	'03→'08	ISON155	5,50

CC	Modello Model	Anno Years	Codice Code	€
450	FS C	'05→'06	ISON155	5,50
450	FS E	'06→'08	ISON155	5,50
450	FX	'10→'11	ISON655	6,14
501	FE 4T	'13→'14	ISON655	6,14
550	FC	'04→'07	ISON155	5,50
550	FE E	'04→'08	ISON155	5,50
550	FS E	'05→'07	ISON155	5,50
570	FE	'09→'12	ISON655	6,14
570	FS Supermoto	'10→'11	ISON655	6,14
650	FE E	'04→'08	ISON155	5,50
650	FS C Supermoto	'06→'08	ISON155	5,50
650	FS E Supermoto	'05→'08	ISON155	5,50
650	FS Supermotard	'04→'07	ISON155	5,50

HUSQVARNA

125	SMR	'11→'13	ISON141	5,56
125	SMS	'12→'13	ISON141	5,56
125	SMS 4	'11→'14	ISON141	5,56
125	TE 4T	'11→'13	ISON141	5,56
250	FC	'14→'20	ISON652	6,01
250	FE	'14→'20	ISON652	6,01
250	TC	'02→'07	ISON154	6,42
250	TC	'08→'09	ISON563	8,31
250	TC	'09→'13	ISON116	3,89
250	TC R	'13	ISON116	3,89
250	TE	'02→'07	ISON154	6,42
250	TE	'10→'13	ISON116	3,89
250	TE MEO Replica	'11	ISON116	3,89
250	TE R 4T	'13	ISON116	3,89
250	TXC	'08→'14	ISON116	3,89
250	TXC R	'13	ISON116	3,89
300	FX	'20	ISON652	6,01
310	TE	'09→'10	ISON563	8,31
310	TE	'11→'14	ISON116	3,89
310	TE R	'13→'13	ISON116	3,89
310	TXC R	'11→'14	ISON116	3,89
350	FC	'14→'20	ISON652	6,01
350	FE	'14→'20	ISON652	6,01
350	FE S	'20	ISON652	6,01
350	FX	'17→'20	ISON652	6,01
401	Svartpilen	'17→'20	ISON155	5,5
401	Vitpilen	'17→'20	ISON155	5,5
410	TE	'98→'01	ISON154	6,42
410	TE E	'00	ISON154	6,42
449	SMR 449	'11→'13	ISON611	6,07
449	TC 449	'11→'13	ISON611	6,07
449	TC 449	'14	ISON145	4,77
449	TE 449	'11→'14	ISON611	6,07
450	FC	'14→'15	ISON655	6,14
450	FC	'16→'20	ISON652	6,01
450	FE	'14→'16	ISON655	6,14
450	FE	'17→'20	ISON652	6,01
450	FS	'15→'20	ISON655	6,14
450	FX	'17→'20	ISON652	6,01
450	SM R	'03→'07	ISON154	6,42
450	SM R	'08→'10	ISON563	8,31
450	SM RR	'08→'10	ISON563	8,31
450	SMR RR	'06→'07	ISON154	6,42
450	TC	'02→'07	ISON154	6,42
450	TC	'08→'10	ISON563	8,31
450	TE	'02→'07	ISON154	6,42



FILTRI ISON / ISON FILTER

CC	Modello Model	Anno Years	Codice Code	€	CC	Modello Model	Anno Years	Codice Code	€
450	TE	'08→'10	ISON563	8,31	125	KLX	'10→'16	ISON112	3,34
501	FE	'14→'17	ISON655	6,14	125	KLX D-Tracker	'10→'14	ISON112	3,34
501	FE	'18→'20	ISON652	6,01	125	KLX L	'03→'06	ISON132	3,34
510	SM R	'05→'07	ISON154	6,42	125	Ninja (BX)	'19→'20	ISON112	3,34
510	SM R	'08→'10	ISON563	8,31	125	Z	'19→'20	ISON112	3,34
510	TC	'05→'07	ISON154	6,42	200	KLT	'81→'84	ISON123	4,28
510	TC	'08→'10	ISON563	8,31	200	Z	'77→'83	ISON123	4,28
510	TE	'04→'07	ISON154	6,42	220	KLF	'88→'02	ISON123	4,28
510	TE	'08→'10	ISON563	8,31	230	KLX	'20	ISON112	3,34
511	SMR 511	'11→'13	ISON611	6,07	250	BJ Estrella	'94→'99	ISON123	4,28
511	TE 511	'11→'14	ISON611	6,07	250	BJ Estrella Custom	'96→'00	ISON123	4,28
530	SM RR	'08→'10	ISON563	8,31	250	BJ Estrella RS	'99→'00	ISON123	4,28
610	SM	'98→'99	ISON154	6,42	250	BJ Estrella RS Custom	'96→'99	ISON123	4,28
610	SM IE	'07→'09	ISON154	6,42	250	EL	'90→'99	ISON401	5,81
610	SM S	'06	ISON154	6,42	250	EL Eliminator	'87→'89	ISON401	5,81
610	TE	'98→'00	ISON154	6,42	250	GPX R	'86→'95	ISON401	5,81
610	TE E	'98→'00	ISON154	6,42	250	KFX Mojave	'04	ISON123	4,28
610	TE IE	'06→'07	ISON154	6,42	250	KL	'78→'85	ISON123	4,28
630	SMR	'10→'11	ISON563	8,31	250	KL	'97	ISON123	4,28
630	TE	'10→'11	ISON563	8,31	250	KLE	'95	ISON123	4,28
701	701 Enduro	'16→'20	ISON155	5,5	250	KLE	'97	ISON123	4,28
701	701 Enduro LR	'20	ISON155	5,5	250	KLF Bayou	'03→'11	ISON123	4,28
701	701 Enduro LR	'20	ISON651	5,67	250	KLR	'85→'05	ISON123	4,28
701	701 Supermoto	'20	ISON155	5,5	250	KLT Prairie	'83→'85	ISON123	4,28
701	701 Supermoto	'20	ISON651	5,67	250	KLX	'93→'19	ISON112	3,34
701	701 Svartpilen	'19→'20	ISON155	5,5	250	KLX	'09→'17	ISON112	3,34
701	701 Svartpilen	'19→'20	ISON651	5,67	250	KLX D-Tracker	'98→'03	ISON112	3,34
701	701 Vitpilen	'18→'20	ISON155	5,5	250	KLX R	'93→'99	ISON112	3,34
701	701 Vitpilen	'18→'20	ISON651	5,67	250	KLX S	'06→'14	ISON112	3,34
900	Nuda	'12→'13	ISON160	10,43	250	KLX SF	'09→'10	ISON112	3,34
900	Nuda R	'12→'13	ISON160	10,43	250	KSF Mojave	'94→'03	ISON123	4,28
HYOSUNG					250	KX F	'04→'20	ISON207	4,54
125	Exceed	'05→'05	ISON131	3,64	250	Ninja R	'08→'12	ISON401	5,81
125	GA Cruise	'97→'01	ISON131	3,64	250	Z	'83	ISON123	4,28
125	GF	'98→'03	ISON131	3,64	250	Z LTD	'81→'82	ISON123	4,28
125	GT Comet	'03→'15	ISON131	3,64	250	Z SL BR	'15→'17	ISON112	3,34
125	GT R Comet	'09→'15	ISON131	3,64	250	Z SL BR ABS	'15→'17	ISON112	3,34
125	GV Aquila	'00→'15	ISON131	3,64	250	Z SL BX Ninja	'15	ISON112	3,34
125	GV C Aquila	'09→'15	ISON131	3,64	250	Z SL BX Ninja ABS	'15	ISON112	3,34
125	RT Karion	'04→'15	ISON131	3,64	250	ZXR	'91→'95	ISON303	8,06
125	RX D	'07→'11	ISON131	3,64	250	ZZR	'90→'03	ISON401	5,81
125	RX SM	'07→'11	ISON131	3,64	252	EL	'96→'97	ISON401	5,81
125	XRX	'00→'08	ISON131	3,64	252	EL	'99→'99	ISON401	5,81
250	GT Comet	'04→'11	ISON131	3,64	252	EL	'01	ISON401	5,81
250	GT R Comet EFI	'09→'15	ISON131	3,64	252	EL	'03	ISON401	5,81
250	GV Aquila	'01→'15	ISON131	3,64	300	J	'14→'16	ISON566	3,61
ITALJET					300	J ABS	'14→'20	ISON566	3,61
125	Dragster	'06	ISON183	5,39	300	KEF Lakota Sport	'01→'03	ISON123	4,28
125	Jet Set	'01→'03	ISON183	5,39	300	KLE Versys-X	'17→'20	ISON303	8,06
125	Torpedo 4T	'00→'03	ISON183	5,39	300	KLF Bayou	'86→'05	ISON123	4,28
150	Jet Set	'01→'03	ISON183	5,39	300	KLX R	'97→'07	ISON112	3,34
150	Torpedo	'00→'03	ISON183	5,39	300	KVF Prairie 2X4	'99→'02	ISON303	8,06
KAWASAKI					300	KVF Prairie 4X4	'99→'02	ISON303	8,06
110	KLX R	'02→'18	ISON112	3,34	300	Ninja	'12→'16	ISON303	8,06
110	KLX R	'02→'20	ISON112	3,34	300	Ninja ABS	'12→'16	ISON303	8,06
125	BN Eliminator	'98→'07	ISON112	3,34	300	Z ABS	'15→'16	ISON303	8,06
125	KLX	'03→'06	ISON132	3,34	300	Z Ninja ABS	'15→'16	ISON303	8,06
					360	KVF	'03→'13	ISON204	8,06
					400	GPX R	'87→'89	ISON401	5,81
					400	GPZ R	'85→'87	ISON401	5,81
					400	KFX	'03→'06	ISON139	4,26
					400	KLF Bayou	'93→'99	ISON303	8,06



FILTRI ISON / ISON FILTER

CC	Modello Model	Anno Years	Codice Code	€
400	KLX R	'03→'04	ISON139	4,26
400	KVF Prairie	'97→'98	ISON303	8,06
400	KVF Prairie 2X4	'99→'01	ISON303	8,06
400	KVF Prairie 4X4	'99→'02	ISON303	8,06
400	Ninja	'18→'20	ISON303	8,06
400	Z	'78→'80	ISON401	5,81
400	Z ABS	'19→'20	ISON303	8,06
400	Z J	'80→'83	ISON401	5,81
400	ZR	'83→'85	ISON401	5,81
400	ZR Xanthus	'92→'95	ISON303	8,06
400	ZX ZF2	'91	ISON401	5,81
400	ZX ZF2	'94	ISON401	5,81
400	ZXR	'89→'99	ISON303	8,06
400	ZXR R	'89→'94	ISON303	8,06
400	ZZR	'90→'99	ISON303	8,06
440	Z	'80→'83	ISON401	5,81
440	Z LTD	'79→'79	ISON401	5,81
440	Z LTD	'82→'84	ISON401	5,81
450	EN LTD	'85→'90	ISON202	6,67
450	KAF Mule 1000	'82→'82	ISON303	8,06
450	KFX R	'08→'14	ISON112	3,34
450	KLX R	'07→'20	ISON112	3,34
450	KX F	'06→'15	ISON112	3,34
450	KX F	'16→'20	ISON207	4,54
500	EN	'90→'09	ISON303	8,06
500	EN	'03→'05	ISON204	8,06
500	ER-5	'97→'07	ISON303	8,06
500	GPZ S	'87→'89	ISON202	6,67
500	GPZ S	'88→'02	ISON303	8,06
500	GPZ S	'03→'04	ISON204	8,06
500	KLE	'91→'02	ISON303	8,06
500	KLE	'03→'07	ISON204	8,06
500	VN Vulcan LTD	'02→'02	ISON303	8,06
500	Z	'79→'81	ISON401	5,81
500	ZZR	'90→'92	ISON303	8,06
540	KAF Mule 2010	'91	ISON303	8,06
540	KAF Mule 2020	'91	ISON303	8,06
540	KAF Mule 2030	'91	ISON303	8,06
550	GPZ	'81→'83	ISON401	5,81
550	GPZ ZX	'84→'88	ISON401	5,81
550	GT	'83→'01	ISON401	5,81
550	Z	'81→'82	ISON401	5,81
550	Z KZ	'80→'82	ISON401	5,81
550	Z LTD	'80→'84	ISON401	5,81
550	ZR Zephyr	'90→'99	ISON401	5,81
550	ZR ZF	'83→'84	ISON401	5,81
600	GPX R	'88→'97	ISON401	5,81
600	GPZ R	'85→'89	ISON401	5,81
600	KLR	'84→'94	ISON123	4,28
600	KLR	'95	ISON132	3,34
600	ZL Eliminator	'95→'97	ISON401	5,81
600	ZX-6R	'95→'16	ISON303	8,06
600	ZX-6RR	'03→'07	ISON204	8,06
600	ZZR	'90→'01	ISON303	8,06
600	ZZR	'02→'04	ISON204	8,06
600	ZZR	'05→'07	ISON303	8,06
636	ZX-6R	'02	ISON204	8,06
636	ZX-6R	'05→'06	ISON204	8,06
636	ZX-6R	'13→'15	ISON303	8,06
636	ZX-6R 30th Anniversary Ed.	'15	ISON303	8,06
636	ZX-6R 30th Anniversary Edition ABS	'15	ISON303	8,06

CC	Modello Model	Anno Years	Codice Code	€
636	ZX-6R ABS	'13→'20	ISON303	8,06
636	ZX-6R KRT Edition ABS	'16→'20	ISON303	8,06
636	ZX-6RR	'03→'04	ISON204	8,06
650	EN Vulcan S	'15→'17	ISON303	8,06
650	EN Vulcan S ABS	'15→'20	ISON303	8,06
650	EN Vulcan S CAFE	'17→'20	ISON303	8,06
650	ER-6F	'05→'16	ISON303	8,06
650	ER-6F ABS	'06→'16	ISON303	8,06
650	ER-6N	'06→'16	ISON303	8,06
650	ER-6N ABS	'06→'16	ISON303	8,06
650	KL Tengai	'89→'91	ISON123	4,28
650	KL Tengai	'92	ISON132	3,34
650	KLE Versys	'07→'16	ISON303	8,06
650	KLE Versys ABS	'07→'20	ISON303	8,06
650	KLE Versys ABS Tourer	'17→'20	ISON303	8,06
650	KLR	'87→'89	ISON123	4,28
650	KLR	'95→'14	ISON123	4,28
650	KLX	'93→'02	ISON123	4,28
650	KLX R	'93→'01	ISON123	4,28
650	KVF Brute Force	'14	ISON204	8,06
650	KVF Brute Force 4X4	'05→'13	ISON204	8,06
650	KVF Brute Force Hardwoods Green 4X4	'05→'09	ISON204	8,06
650	KVF Prairie	'02→'03	ISON204	8,06
650	Ninja ABS	'17→'20	ISON303	8,06
650	Ninja Tourer ABS	'20	ISON303	8,06
650	W	'99→'06	ISON204	8,06
650	Z	'77→'83	ISON401	5,81
650	Z ABS	'17→'20	ISON303	8,06
650	Z Custom	'77→'79	ISON401	5,81
650	Z SR	'79→'80	ISON401	5,81
700	KFX KSV V-Force	'04→'11	ISON204	8,06
700	KVF Prairie 4X4	'04→'08	ISON204	8,06
700	KVF Team Green	'05	ISON204	8,06
700	VN Vulcan	'85	ISON202	6,67
750	GPX R	'87→'90	ISON401	5,81
750	GPZ	'82	ISON401	5,81
750	GPZ R	'85→'87	ISON401	5,81
750	GPZ Turbo	'83→'87	ISON401	5,81
750	GPZ X Unitrak	'83→'87	ISON401	5,81
750	GT KZ	'82→'96	ISON401	5,81
750	KRF Teryx 4X4	'08→'09	ISON204	8,06
750	KRF Teryx FI 4X4	'10→'13	ISON204	8,06
750	KRF Teryx Outdoors 4X4	'08→'08	ISON204	8,06
750	KVF Brute Force	'04	ISON204	8,06
750	KVF Brute Force	'06→'14	ISON204	8,06
750	VN Vulcan	'86→'98	ISON202	6,67
750	VN Vulcan	'99→'03	ISON303	8,06
750	VN Vulcan	'04→'06	ISON204	8,06
750	Z	'79→'84	ISON401	5,81
750	Z	'04→'06	ISON204	8,06
750	Z	'07→'13	ISON303	8,06
750	Z ABS	'07→'13	ISON303	8,06
750	Z LTD	'80→'82	ISON401	5,81
750	Z R	'11→'12	ISON303	8,06
750	Z R ABS	'11→'12	ISON303	8,06
750	Z R Black Edition	'12→'12	ISON303	8,06
750	Z S	'05→'06	ISON204	8,06
750	Z S	'07	ISON303	8,06
750	Z Spectre	'82→'83	ISON401	5,81
750	Zephyr	'91→'98	ISON401	5,81
750	ZR-7	'99→'04	ISON401	5,81



FILTRI ISON / ISON FILTER

CC	Modello Model	Anno Years	Codice Code	€	CC	Modello Model	Anno Years	Codice Code	€
750	ZR-7S	'01→'05	ISON401	5,81	1000	ZX-10R ABS 30th Anniversary Edition	'15→'15	ISON303	8,06
750	ZX-7R	'96→'03	ISON303	8,06	1000	ZX-10R KRT Replica	'19→'20	ISON303	8,06
750	ZX-7RR	'96→'99	ISON303	8,06	1000	ZX-10R SE	'18→'20	ISON303	8,06
750	ZXR	'89	ISON303	8,06	1000	ZX-10RR	'17→'18	ISON303	8,06
750	ZXR	'90	ISON401	5,81	1100	GPZ	'82→'83	ISON401	5,81
750	ZXR	'91→'95	ISON303	8,06	1100	GPZ	'95→'99	ISON401	5,81
750	ZXR R	'92→'95	ISON303	8,06	1100	GPZ ABS	'96→'98	ISON401	5,81
800	KRF Teryx	'14	ISON204	8,06	1100	GPZ X	'83→'85	ISON401	5,81
800	KRT Teryx 4	'14	ISON204	8,06	1100	Z	'81→'83	ISON401	5,81
800	VN	'95→'02	ISON303	8,06	1100	Z Lawson Replica	'84	ISON401	5,81
800	VN	'03→'05	ISON204	8,06	1100	ZR Zephyr	'92→'97	ISON401	5,81
800	VN Classic	'96→'01	ISON303	8,06	1100	ZR Zephyr	'02	ISON401	5,81
800	VN Classic	'02→'06	ISON204	8,06	1100	ZRX	'97→'00	ISON401	5,81
800	VN Drifter	'99→'02	ISON303	8,06	1100	ZZR	'90→'01	ISON401	5,81
800	VN Drifter	'03→'06	ISON204	8,06	1200	ZRX R	'01→'08	ISON401	5,81
800	W	'11→'16	ISON303	8,06	1200	ZRX S	'01→'07	ISON401	5,81
800	W	'20	ISON303	8,06	1200	ZX-12R	'00→'06	ISON204	8,06
800	W Cafè	'19→'20	ISON303	8,06	1200	ZZR	'02→'05	ISON401	5,81
800	W Cafe Style	'11	ISON303	8,06	1400	GTR	'08→'20	ISON303	8,06
800	W Special EDITION	'12→'14	ISON303	8,06	1400	ZZR	'06→'08	ISON303	8,06
800	W Street	'19→'20	ISON303	8,06	1400	ZZR ABS	'06→'20	ISON303	8,06
800	Z	'13→'16	ISON303	8,06	1400	ZZR Performance Sport ABS	'16→'20	ISON303	8,06
800	Z ABS	'13→'16	ISON303	8,06	1500	VN	'87→'97	ISON303	8,06
800	Z E	'13→'16	ISON303	8,06	1500	VN 15 SE	'88→'92	ISON303	8,06
800	Z E ABS	'13→'16	ISON303	8,06	1500	VN Classic	'96→'98	ISON303	8,06
800	Z E Special Edition	'16	ISON303	8,06	1500	VN Classic	'99	ISON204	8,06
800	Z E Special Edition ABS	'16	ISON303	8,06	1500	VN Classic	'07→'08	ISON303	8,06
900	GPZ R	'84→'96	ISON401	5,81	1500	VN Classic FI	'00→'04	ISON204	8,06
900	VN Classic	'06→'19	ISON303	8,06	1500	VN Classic Tourer	'98→'99	ISON303	8,06
900	VN Classic LT	'06→'19	ISON303	8,06	1500	VN Classic Tourer FI	'00	ISON303	8,06
900	VN Classic Special Edition	'11→'16	ISON303	8,06	1500	VN Classic Tourer FI	'01→'04	ISON204	8,06
900	VN Custom	'07→'20	ISON303	8,06	1500	VN Drifter	'99→'05	ISON204	8,06
900	Z	'76→'77	ISON401	5,81	1500	VN Mean Streak	'02→'04	ISON204	8,06
900	Z ABS	'17→'20	ISON303	8,06	1500	VN Nomad	'99→'01	ISON204	8,06
900	Z RS	'18→'20	ISON303	8,06	1600	VN Classic	'03→'06	ISON204	8,06
900	Z RS Cafe	'18→'20	ISON303	8,06	1600	VN Classic	'07→'08	ISON303	8,06
900	ZL Eliminator	'85→'86	ISON401	5,81	1600	VN Classic Tourer	'05→'06	ISON204	8,06
900	ZX-9R	'94→'01	ISON303	8,06	1600	VN Classic Tourer	'07→'08	ISON303	8,06
900	ZX-9R	'02→'04	ISON204	8,06	1600	VN Mean Streak	'04→'06	ISON204	8,06
1000	GPZ RX	'86→'88	ISON401	5,81	1600	VN Mean Streak	'07→'08	ISON303	8,06
1000	GTR	'86→'06	ISON401	5,81	1700	VN Classic	'09	ISON303	8,06
1000	KLV	'04→'05	ISON138	8,06	1700	VN Classic ABS	'10→'14	ISON303	8,06
1000	KLZ Versys	'12→'18	ISON303	8,06	1700	VN Classic Tourer	'09	ISON303	8,06
1000	KLZ Versys	'19→'20	ISON303	8,06	1700	VN Classic Tourer ABS	'10→'15	ISON303	8,06
1000	KLZ Versys SE	'19→'20	ISON303	8,06	1700	VN Vaquero ABS	'19→'20	ISON303	8,06
1000	Ninja SX	'20	ISON303	8,06	1700	VN Voyager ABS	'09→'20	ISON303	8,06
1000	Z	'81→'83	ISON401	5,81	1700	VN Voyager Custom	'11→'14	ISON303	8,06
1000	Z	'03→'06	ISON204	8,06	1700	VN Vulcan Nomad ABS	'15→'16	ISON303	8,06
1000	Z	'07→'13	ISON303	8,06	2000	VN	'04→'07	ISON204	8,06
1000	Z ABS	'07→'16	ISON303	8,06	2000	VN Classic	'08→'09	ISON303	8,06
1000	Z ABS	'17→'20	ISON303	8,06					
1000	Z LTD	'81→'83	ISON401	5,81					
1000	Z R	'17→'20	ISON303	8,06					
1000	Z R2	'83→'83	ISON401	5,81					
1000	Z SX	'11→'13	ISON303	8,06					
1000	Z SX ABS	'11→'20	ISON303	8,06					
1000	ZL	'87→'88	ISON401	5,81					
1000	ZX-10	'88→'90	ISON401	5,81					
1000	ZX-10R	'04→'06	ISON204	8,06					
1000	ZX-10R	'07→'15	ISON303	8,06					
1000	ZX-10R 30th Anniversary Ed.	'15	ISON303	8,06					
1000	ZX-10R ABS	'11→'15	ISON303	8,06					
1000	ZX-10R ABS	'16→'19	ISON303	8,06					

KEEWAY			
250	Cruiser	'11	ISON145 4,77
250	Landcruiser	'06→'08	ISON145 4,77
250	Super Shadow	'06→'08	ISON145 4,77

KTM			
125	Duke	'11→'12	ISON155 5,50
125	Duke ABS	'13→'20	ISON155 5,50
125	RC	'14→'20	ISON155 5,50



FILTRI ISON / ISON FILTER

CC	Modello Model	Anno Years	Codice Code	€	CC	Modello Model	Anno Years	Codice Code	€
200	Duke	'12→'14	ISON155	5,50	450	SMR	'13→'14	ISON655	6,14
200	Duke ABS	'13→'20	ISON155	5,50	450	SX Racing	'03→'06	ISON155	5,50
200	RC	'14→'19	ISON155	5,50	450	SX-F	'03→'06	ISON155	5,50
250	Duke	'15→'20	ISON155	5,50	450	SX-F	'07→'12	ISON652	6,01
250	EXC Racing	'01→'06	ISON155	5,50	450	SX-F	'13→'15	ISON655	6,14
250	EXC Racing SIX Days	'02→'03	ISON155	5,50	450	SX-F	'16→'20	ISON652	6,01
250	EXC-F	'06→'13	ISON655	6,14	450	SX-F Cairoli Replica	'20	ISON652	6,01
250	EXC-F	'14→'20	ISON652	6,01	450	SX-F Herlings Replica	'19	ISON652	6,01
250	EXC-F Champion Edition	'10→'10	ISON655	6,14	450	XC Quad	'07→'10	ISON155	5,50
250	EXC-F Factory Edition	'11	ISON655	6,14	450	XC-F	'08→'09	ISON655	6,14
250	EXC-F Factory Edition	'15	ISON652	6,01	450	XC-F	'13→'20	ISON655	6,14
250	EXC-F Racing	'02→'06	ISON155	5,50	500	EXC	'12→'19	ISON655	6,14
250	EXC-F Six Days	'07→'13	ISON655	6,14	500	EXC LC-4	'89	ISON155	5,50
250	EXC-F Six Days	'14→'20	ISON652	6,01	500	EXC Six Days	'12→'19	ISON655	6,14
250	Freeride F	'18→'20	ISON652	6,01	500	EXC-F	'17→'18	ISON655	6,14
250	RC	'15→'17	ISON155	5,50	500	EXC-F	'19→'20	ISON652	6,01
250	SX-F	'06→'12	ISON655	6,14	500	EXC-F Six Days	'17→'18	ISON655	6,14
250	SX-F	'13→'20	ISON652	6,01	500	EXC-F Six Days	'19→'20	ISON652	6,01
250	XC-F	'11→'12	ISON655	6,14	500	GS	'85	ISON151	6,42
250	XC-F	'13→'20	ISON652	6,01	504	GS	'83	ISON151	6,42
350	EXC-F	'11→'20	ISON652	6,01	505	SX Quad	'08→'13	ISON158	6,73
350	EXC-F Six Days	'12→'20	ISON652	6,01	505	SX-F	'07→'09	ISON652	6,01
350	Freeride	'12→'16	ISON652	6,01	505	XC-F	'09	ISON652	6,01
350	SX-F	'10→'20	ISON652	6,01	520	EXC Racing	'00→'02	ISON155	5,50
350	XC-F	'12→'20	ISON652	6,01	520	EXC Racing Six Days	'01→'02	ISON155	5,50
390	Adventure	'20	ISON155	5,50	520	EXC-E	'99	ISON155	5,50
390	Duke ABS	'14→'20	ISON155	5,50	520	SX Racing	'00→'03	ISON155	5,50
390	RC ABS	'14→'20	ISON155	5,50	525	EXC Factory	'05	ISON155	5,50
390	RC R	'18	ISON155	5,50	525	EXC Factory Racing	'07	ISON155	5,50
400	DUKE	'95	ISON155	5,50	525	EXC Racing	'03→'07	ISON155	5,50
400	EGS Enduro	'99	ISON155	5,50	525	EXC Racing Six Days	'03→'07	ISON155	5,50
400	EGS LC4 Enduro	'96→'98	ISON155	5,50	525	MXC Desert Racing	'03→'05	ISON155	5,50
400	EGS-E LC4 Enduro	'97	ISON155	5,50	525	SMR	'04→'05	ISON155	5,50
400	EXC	'09→'11	ISON652	6,01	525	SX	'03→'06	ISON155	5,50
400	EXC Factory Edition	'11	ISON652	6,01	525	XC Desert Racing	'04→'07	ISON155	5,50
400	EXC Factory Racing	'05→'07	ISON155	5,50	525	XC Quad	'08→'12	ISON155	5,50
400	EXC Racing	'00→'07	ISON155	5,50	530	EXC	'09→'11	ISON652	6,01
400	EXC Racing Six Days	'01→'03	ISON155	5,50	530	EXC Factory Edition	'11	ISON652	6,01
400	EXC-E Racing	'99	ISON155	5,50	530	EXC Six Days	'09→'12	ISON652	6,01
400	LC4	'98→'99	ISON155	5,50	530	EXC-R	'08	ISON652	6,01
400	LC4-E	'98→'01	ISON155	5,50	530	EXC-R Six Days	'08	ISON652	6,01
400	LSE	'96→'97	ISON155	5,50	540	SXC	'98	ISON155	5,50
400	SC LC4 Supercompetition	'95→'99	ISON155	5,50	560	SMR	'06→'07	ISON155	5,50
400	Sx	'00→'02	ISON155	5,50	600	LC4 Incas	'89→'90	ISON151	6,42
400	SX-C	'97→'99	ISON155	5,50	620	Competition Limited	'97	ISON155	5,50
450	EXC	'06	ISON155	5,50	620	Duke	'93→'99	ISON155	5,50
450	EXC	'09→'11	ISON652	6,01	620	EGS	'94→'99	ISON155	5,50
450	EXC	'12→'16	ISON655	6,14	620	EGS-E	'97	ISON155	5,50
450	EXC Champion Edition	'10→'10	ISON652	6,01	620	EGS-E Adventure	'97	ISON155	5,50
450	EXC Factory	'05	ISON155	5,50	620	LC4 Competition	'99	ISON155	5,50
450	EXC Factory Racing	'07	ISON155	5,50	620	LC4 Supermoto	'99	ISON155	5,50
450	EXC Racing	'03→'07	ISON155	5,50	620	SC Supermoto	'00→'01	ISON155	5,50
450	EXC Racing Six Days	'04→'07	ISON155	5,50	620	SX	'94→'99	ISON155	5,50
450	EXC Six Days	'09→'11	ISON652	6,01	625	LC4 Super-Competition	'02	ISON155	5,50
450	EXC Six Days	'12→'16	ISON655	6,14	625	SC	'02	ISON155	5,50
450	EXC-F	'17→'20	ISON652	6,01	625	SMC	'04→'06	ISON155	5,50
450	EXC-F Six Days	'17→'20	ISON652	6,01	625	SXC	'03→'07	ISON155	5,50
450	EXC-R	'08→'08	ISON652	6,01	625	SXC	'05→'07	ISON156	9,34
450	EXC-R Six Days	'08	ISON652	6,01	640	Adventure	'05→'07	ISON155	5,50
450	Rally Factory Replica	'11	ISON158	6,73	640	Adventure R	'98→'04	ISON155	5,50
450	SMR	'04→'07	ISON155	5,50	640	Duke II	'98→'07	ISON155	5,50
450	SMR	'08→'12	ISON652	6,01	640	LC4 Adventure	'03→'06	ISON155	5,50



FILTRI ISON / ISON FILTER

CC	Modello Model	Anno Years	Codice Code	€
640	LC4 Enduro	'98→'06	ISON155	5,50
640	LC4 Six Days	'99	ISON155	5,50
640	LC4 Supermoto	'99→'06	ISON155	5,50
640	LC4 Supermoto Prestige	'03→'06	ISON155	5,50
640	LC4-E Enduro	'00→'02	ISON155	5,50
640	LC4-E Six Days	'02	ISON155	5,50
640	LC4-E Supermoto	'00→'02	ISON155	5,50
660	LC4 Rally	'99→'02	ISON155	5,50
660	Rally Factory Replica	'03→'07	ISON155	5,50
660	SM Factory Replica	'02	ISON155	5,50
660	SM Factory Replica	'02→'03	ISON157	5,67
660	SMC	'03→'06	ISON155	5,50
660	SMC	'04→'06	ISON156	9,34
660	Supermoto Factory Replica	'03	ISON155	5,50
690	Duke	'08→'12	ISON157	5,67
690	Duke ABS	'12→'19	ISON155	5,50
690	Duke R	'10→'12	ISON155	5,50
690	Duke R ABS	'13→'18	ISON155	5,50
690	Enduro	'08→'10	ISON155	5,50
690	Enduro R	'09→'13	ISON155	5,50
690	Enduro R ABS	'14→'20	ISON155	5,50
690	Rally Factory Replica	'07→'08	ISON655	6,14
690	Rally Factory Replica	'09→'10	ISON155	5,50
690	SMC	'08→'11	ISON155	5,50
690	SMC R	'12→'13	ISON155	5,50
690	SMC R ABS	'14→'20	ISON155	5,50
690	Supermoto	'07→'10	ISON155	5,50
690	Supermoto Limited Edition	'09	ISON155	5,50
690	Supermoto Prestige	'07	ISON155	5,50
690	Supermoto R	'08	ISON155	5,50
950	Adventure	'02→'05	ISON158	6,73
950	Adventure S	'03→'06	ISON158	6,73
950	Super Enduro R	'06→'08	ISON158	6,73
950	Supermoto	'05→'08	ISON158	6,73
950	Supermoto R	'07→'08	ISON158	6,73
990	Adventure ABS	'06→'12	ISON158	6,73
990	Adventure Dakar Edition ABS	'11	ISON158	6,73
990	Adventure Limited Edition ABS	'10	ISON158	6,73
990	Adventure R	'09→'18	ISON158	6,73
990	Adventure S	'06→'08	ISON158	6,73
990	Super Duke	'05→'11	ISON158	6,73
990	Super Duke R	'07→'13	ISON158	6,73
990	Supermoto	'08→'10	ISON158	6,73
990	Supermoto R	'09→'12	ISON158	6,73
990	Supermoto R ABS	'12→'13	ISON158	6,73
990	Supermoto T	'09→'10	ISON158	6,73
990	Supermoto T ABS	'11→'13	ISON158	6,73
1050	Adventure ABS	'15→'16	ISON158	6,73
1090	Adventure	'17→'19	ISON158	6,73
1090	Adventure R	'17→'19	ISON158	6,73
1190	Adventure ABS	'13→'16	ISON158	6,73
1190	Adventure R ABS	'13→'16	ISON158	6,73
1190	RC8	'08→'11	ISON158	6,73
1190	RC8 R	'09→'16	ISON158	6,73
1190	RC8 R Track	'11→'13	ISON158	6,73
1290	SUPER Adventure	'15→'17	ISON158	6,73
1290	SUPER Adventure R	'18→'20	ISON158	6,73
1290	Super Adventure S	'18→'20	ISON158	6,73
1290	Super Adventure T	'17→'17	ISON158	6,73
1290	Super Duke GT	'16→'20	ISON158	6,73
1290	Super Duke R	'14→'20	ISON158	6,73

CC	Modello Model	Anno Years	Codice Code	€
1290	Super Duke R SE	'16→'17	ISON158	6,73

KYMCO

125	Dink I	'06→'15	ISON562	3,34
125	Downtown I	'09→'11	ISON566	3,61
125	Downtown I ABS	'12→'19	ISON566	3,61
125	G-Dink I	'12→'16	ISON562	3,34
125	Grand Dink	'01→'08	ISON562	3,34
125	Grand Dink S	'09→'15	ISON562	3,34
125	Grand Dink/Miler	'01→'07	ISON562	3,34
125	K-XCT I	'12→'15	ISON566	3,61
125	People GT I	'10→'14	ISON566	3,61
125	Super Dink I	'09→'14	ISON566	3,61
125	X-Town I ABS	'16→'19	ISON566	3,61
150	Grand Dink	'08→'11	ISON562	3,34
150	Grand Dink/Miler	'01→'07	ISON562	3,34
200	Dink I	'06→'15	ISON562	3,34
200	Downtown I	'10→'15	ISON566	3,61
200	People GT I	'10→'15	ISON566	3,61
200	Yager I	'07	ISON562	3,34
200	Yager I	'09→'13	ISON562	3,34
300	Downtown I	'09→'13	ISON566	3,61
300	Downtown I ABS	'10→'16	ISON566	3,61
300	K-XCT I	'12→'16	ISON566	3,61
300	People GT I	'10→'16	ISON566	3,61
300	People GT I ABS	'14→'16	ISON566	3,61
350	Downtown I	'15→'16	ISON566	3,61
350	Downtown I	'19	ISON566	3,61
350	Downtown I (Exclusive) ABS	'15→'19	ISON566	3,61
350	Downtown I (Exclusive) TCS	'18	ISON566	3,61
400	Maxxer	'09→'10	ISON138	8,06
400	MXU	'08→'11	ISON138	8,06
450	Maxxer	'10→'15	ISON138	8,06
450	MXU I	'11→'15	ISON138	8,06
500	MXU	'05→'13	ISON147	8,34
500	MXU I DX	'12→'13	ISON147	8,34
500	MXU I IRS	'09→'14	ISON147	8,34
500	UXV	'08→'09	ISON147	8,34
500	UXV I	'10→'15	ISON147	8,34
500	Xciting	'05	ISON147	8,34
500	Xciting I	'06→'08	ISON147	8,34
500	Xciting I EVO ABS	'13	ISON147	8,34
500	Xciting I R	'07→'16	ISON147	8,34
550	AK	'17→'20	ISON164	10,43
550	MXU I	'12→'15	ISON147	8,34
550	MXU I	'13→'15	ISON147	8,34
700	MXU I	'13→'15	ISON147	8,34
700	MY Road I	'11→'16	ISON147	8,34
700	UXV I Turf	'14→'15	ISON147	8,34

MALAGUTI

125	Madison 3	'07→'12	ISON183	5,39
200	F12 Phantom Max	'03→'06	ISON183	5,39
200	Madison S	'02→'06	ISON183	5,39
250	F12 Phatom Max	'05→'06	ISON183	5,39
250	Madison 3 IE	'06→'12	ISON183	5,39
250	Madison RS	'03→'06	ISON183	5,39
250	Madison S	'99→'03	ISON183	5,39
500	Spidermax GT	'04→'11	ISON184	6,41
500	Spidermax RS	'08→'11	ISON184	6,41



FILTRI ISON / ISON FILTER

CC	Modello Model	Anno Years	Codice Code	€
MASH				
125	Black Seven Euro 4	'17→'19	ISON131	3,64
125	Café Racer Euro 3	'14→'16	ISON131	3,64
125	Café Racer Euro 4	'17→'19	ISON131	3,64
125	Scrambler Euro 3	'14→'17	ISON131	3,64
125	Seventy Euro 3	'13→'17	ISON131	3,64
125	Seventy Five Euro 3	'14→'18	ISON131	3,64
125	Seventy Five Euro 4	'19→'19	ISON131	3,64
125	Sixty Five Euro 3	'13→'15	ISON131	3,64
250	Two Fifty	'14→'19	ISON136	4,89
400	Café Racer	'17→'18	ISON112	3,34
400	Family Side	'17	ISON112	3,34
400	Five Hundred Roadstar	'13→'18	ISON112	3,34
400	Scrambler	'17→'19	ISON112	3,34

MBK

125	City Cruiser	'07→'11	ISON141	5,56
125	Cityliner	'07→'15	ISON141	5,56
125	Flame XC	'95→'03	ISON143	7,76
125	Vertex	'97→'98	ISON143	7,76

MOTO GUZZI

350	354	'74→'75	ISON401	5,81
350	GTS	'74→'79	ISON401	5,81
400	GTS	'74→'79	ISON401	5,81
850	Breva	'06→'11	ISON551	9,34
850	Griso	'06→'11	ISON551	9,34
850	Norge T-GTL	'07→'12	ISON551	9,34
850	T5	'89→'05	ISON551	9,34
940	Bellagio	'07→'14	ISON551	9,34
940	Bellagio Aquila Nera	'07→'14	ISON551	9,34
1000	Daytona	'92→'95	ISON551	9,34
1000	Daytona RS	'96→'01	ISON551	9,34
1000	Quota	'94→'97	ISON551	9,34
1000	V10 Centauro	'97→'99	ISON551	9,34
1000	V10 Centauro GT	'99→'01	ISON551	9,34
1000	V10 Centauro Sport	'98→'01	ISON551	9,34
1100	Breva	'05→'09	ISON551	9,34
1100	Breva ABS	'05→'07	ISON551	9,34
1100	California	'94→'97	ISON551	9,34
1100	California 90 Anniversario	'11→'13	ISON551	9,34
1100	California Aluminium	'03→'05	ISON551	9,34
1100	California Aquila Nera	'09→'11	ISON551	9,34
1100	California Classic	'06→'12	ISON551	9,34
1100	California EV	'97→'05	ISON551	9,34
1100	California EV Touring	'03→'05	ISON551	9,34
1100	California Jackal	'99→'02	ISON551	9,34
1100	California Metal	'02→'03	ISON551	9,34
1100	California Special	'98→'02	ISON551	9,34
1100	California Special Sport	'01→'02	ISON551	9,34
1100	California Stone	'01→'05	ISON551	9,34
1100	California Titanium	'03→'05	ISON551	9,34
1100	California Touring	'06→'12	ISON551	9,34
1100	California Vintage	'06→'13	ISON551	9,34
1100	Griso	'05→'08	ISON551	9,34
1100	Le Mans	'01→'04	ISON551	9,34
1100	Quota Es	'99→'02	ISON551	9,34
1100	Sport	'94→'96	ISON551	9,34
1100	Sport Corsa	'98→'99	ISON551	9,34

CC	Modello Model	Anno Years	Codice Code	€
1100	Sport IE	'96→'99	ISON551	9,34
1100	V11 Cafe Sport	'03→'05	ISON551	9,34
1100	V11 Coppa Italia	'03→'05	ISON551	9,34
1100	V11 Le Mans	'01→'05	ISON551	9,34
1100	V11 Le Mans Nero Corsa	'03→'05	ISON551	9,34
1100	V11 Le Mans Rosso Corsa	'03→'05	ISON551	9,34
1100	V11 Scura R	'02→'02	ISON551	9,34
1100	V11 Sport	'99→'02	ISON551	9,34
1100	V11 Sport Ballabio	'03→'05	ISON551	9,34
1100	V11 Sport Naked	'02→'05	ISON551	9,34
1100	V11 Sport Scura	'02→'03	ISON551	9,34
1200	Breva	'08→'11	ISON551	9,34
1200	Breva ABS	'08→'11	ISON551	9,34
1200	Griso 8V	'07→'13	ISON551	9,34
1200	Griso 8V Special Edition	'09→'16	ISON551	9,34
1200	MG5-01 Corsa	'07→'11	ISON551	9,34
1200	Norge ABS	'06→'10	ISON551	9,34
1200	Norge GT 8V	'10→'16	ISON551	9,34
1200	Sport	'06→'07	ISON551	9,34
1200	Sport 4V	'08→'13	ISON551	9,34
1200	Sport 4V ABS	'08→'13	ISON551	9,34
1200	Stelvio	'08→'11	ISON551	9,34
1200	Stelvio 8V	'11→'15	ISON551	9,34
1200	Stelvio NTX	'09→'10	ISON551	9,34
1200	Stelvio NTX 8V	'11→'16	ISON151	6,42
1400	Audace	'15→'19	ISON565	9,47
1400	Audace Carbon	'17→'19	ISON565	9,47
1400	California Corazzieri	'16	ISON565	9,47
1400	California Custom ABS	'12	ISON565	9,47
1400	California Touring	'12→'19	ISON565	9,47
1400	California Touring ABS S.E.	'15→'16	ISON565	9,47
1400	Eldorado	'15→'19	ISON565	9,47
1400	MGX-21 Flying Fortress	'16→'19	ISON565	9,47

MV AGUSTA

989	Brutale R	'07→'11	ISON204	8,06
1000	F4 312R	'07→'08	ISON204	8,06
1078	Brutale RR	'08→'09	ISON204	8,06
1078	F4 312RR	'07→'09	ISON204	8,06
1078	F4 Claudio Castiglioni	'07	ISON204	8,06

MZ-MUZ

125	Fun X	'99	ISON151	6,42
125	Moskito	'99→'00	ISON151	6,42
125	RT	'00→'08	ISON151	6,42
125	SM	'00→'08	ISON151	6,42
500	Red Star Classic	'97	ISON151	6,42
500	Saxon	'91→'97	ISON151	6,42
500	Silver Star Classic	'91→'98	ISON151	6,42
660	Baghira	'98→'00	ISON145	4,77
660	Mastiff	'98→'00	ISON145	4,77
660	Skorpion Cup	'99→'01	ISON145	4,77
660	Skorpion Sport	'94→'99	ISON145	4,77
660	Skorpion Traveller	'96→'00	ISON145	4,77
850	Kobra	'94	ISON145	4,77

PEUGEOT

125	City Star	'11→'15	ISON185	3,47
125	City Star Active I	'13→'13	ISON185	3,47



FILTRI ISON / ISON FILTER

CC	Modello Model	Anno Years	Codice Code	€
125	City Star Blue Line	'15→'15	ISON185	3,47
125	City Star I	'13→'19	ISON185	3,47
125	Elyseo	'98→'01	ISON185	3,47
125	Elyseo	'03	ISON185	3,47
125	Elystar	'02→'10	ISON185	3,47
125	Geo RS	'07→'12	ISON185	3,47
125	Geopolis ABS	'07→'13	ISON185	3,47
125	Geopolis Executive	'07→'13	ISON185	3,47
125	Jet Force	'03→'11	ISON185	3,47
125	Looxor	'03→'06	ISON183	5,39
125	Ludix Ambition	'04→'04	ISON185	3,47
125	Satelis Blacksat	'10→'12	ISON185	3,47
125	Satelis Blue Line	'15→'15	ISON185	3,47
125	Satelis City 4V	'06→'09	ISON185	3,47
125	Satelis Compressor	'06→'12	ISON185	3,47
125	Satelis Executive 4V	'06→'09	ISON185	3,47
125	Satelis Premium 4V	'06→'09	ISON185	3,47
125	Satelis RS	'07→'12	ISON185	3,47
125	Satelis RS	'13	ISON185	3,47
125	Satelis Urban ABS	'07→'12	ISON185	3,47
125	Satelis Whitesat	'10→'12	ISON185	3,47
150	Elyseo	'00→'03	ISON185	3,47
150	Elystar	'02→'10	ISON183	5,39
150	Looxor	'03→'06	ISON183	5,39
250	GEO	'07→'11	ISON183	5,39
250	GEO RS	'08→'10	ISON183	5,39
250	Geopolis	'07→'12	ISON183	5,39
250	Geopolis Executive	'07→'12	ISON183	5,39
250	Geopolis Premium	'07→'11	ISON183	5,39
250	Geopolis Urban ABS	'07→'11	ISON183	5,39
250	Satelis	'07→'12	ISON183	5,39
250	Satelis Premium	'07→'12	ISON183	5,39
250	Satelis RS	'07→'12	ISON183	5,39
250	Satelis Urban ABS	'07→'12	ISON183	5,39
300	GEO RS	'10→'12	ISON183	5,39
300	Geopolis	'10→'13	ISON183	5,39
300	Geopolis GT	'14→'15	ISON183	5,39
300	Geostyle	'10→'12	ISON183	5,39
300	Satelis	'13	ISON183	5,39
300	Satelis 2	'14→'15	ISON183	5,39
400	GEO RS	'08→'12	ISON184	6,41
400	Geopolis	'07→'13	ISON184	6,41
400	Geopolis GT	'14	ISON184	6,41
400	Geopolis Premium	'07→'12	ISON184	6,41
400	Geopolis Urban ABS	'07→'12	ISON184	6,41
400	Satelis	'07→'13	ISON184	6,41
400	Satelis Premium	'08→'11	ISON184	6,41
400	Satelis RS	'08→'12	ISON184	6,41
400	Satelis Urban	'08→'12	ISON184	6,41
500	Geopolis	'08→'13	ISON184	6,41
500	Satelis	'07→'13	ISON184	6,41
500	Satelis RS	'08→'12	ISON184	6,41

PIAGGIO

125	Beverly	'01→'03	ISON183	5,39
125	Beverly Euro 3	'07→'08	ISON183	5,39
125	Beverly Euro 3 MIC	'07	ISON183	5,39
125	Beverly Euro 3 Sport	'07→'08	ISON183	5,39
125	Beverly RST	'04→'05	ISON183	5,39
125	Beverly RST	'05→'07	ISON183	5,39
125	Beverly RST 4T 4V IE Euro 3	'10→'15	ISON183	5,39

CC	Modello Model	Anno Years	Codice Code	€
125	Beverly Tourer Euro 3	'07→'10	ISON183	5,39
125	Carnaby	'07→'10	ISON183	5,39
125	Fly	'05→'07	ISON183	5,39
125	Fly 4T 3V IE Euro 3	'12→'13	ISON183	5,39
125	Fly 4T 3V IE Euro 3 DT	'13→'15	ISON183	5,39
125	Fly Euro 3	'07	ISON183	5,39
125	Fly Euro 3	'08→'11	ISON183	5,39
125	Hexagon GTX	'00	ISON183	5,39
125	Liberty	'01→'02	ISON183	5,39
125	Liberty 4T	'06→'07	ISON183	5,39
125	Liberty 4T 2V Euro 3	'09→'12	ISON183	5,39
125	Liberty 4T 2V IE PTT - ITA	'12→'13	ISON183	5,39
125	Liberty 4T 3V IE	'15→'15	ISON183	5,39
125	Liberty 4T 3V IE EURO 3	'13→'14	ISON183	5,39
125	Liberty 4T Euro 3	'06→'08	ISON183	5,39
125	Liberty 4T Euro 3 Delivery-Single	'07→'15	ISON183	5,39
125	Liberty 4T Euro 3 Delivery Tnt-Nexive	'08→'15	ISON183	5,39
125	Liberty 4T Iget Corporate Euro 4	'17→'19	ISON183	5,39
125	Liberty 4T Sport EURO 3	'06→'08	ISON183	5,39
125	Liberty IGET 4T 3V IE	'15→'19	ISON183	5,39
125	Liberty RST	'04→'05	ISON183	5,39
125	Liberty RST PTT	'05→'11	ISON183	5,39
125	Liberty Sport	'06→'06	ISON183	5,39
125	Medley 4T IE ABS	'16→'19	ISON183	5,39
125	MP3	'06→'08	ISON183	5,39
125	MP3 Ibrido	'09→'10	ISON183	5,39
125	MP3 IE	'08→'11	ISON183	5,39
125	MP3 IE Touring	'11→'12	ISON183	5,39
125	MP3 Yourban ERL	'11→'13	ISON183	5,39
125	Skipper 4T	'00→'02	ISON183	5,39
125	Super Hexagon GTX 12"	'01→'02	ISON183	5,39
125	Typhoon 4T 2V EURO 3	'10→'11	ISON183	5,39
125	Vespa 946 4T 3V ABS-946 Red	'13→'17	ISON183	5,39
125	Vespa 946 4T 3V ABS Armani	'15→'15	ISON183	5,39
125	vespa ET4	'99→'02	ISON183	5,39
125	Vespa Granturismo	'03→'05	ISON183	5,39
125	Vespa Granturismo	'06→'07	ISON183	5,39
125	Vespa Granturismo Euro 3	'06→'07	ISON183	5,39
125	Vespa GTS 4T IE Super	'09→'16	ISON183	5,39
125	Vespa GTS Euro 3	'07→'12	ISON183	5,39
125	Vespa GTS IE ABS Euro 4	'16→'18	ISON183	5,39
125	Vespa GTS IE ABS Euro 4	'19→'19	ISON183	5,39
125	Vespa GTS IE ABS Euro 4 ABS 4T Super	'18→'19	ISON183	5,39
125	Vespa GTV	'06→'08	ISON183	5,39
125	Vespa GTV 4T Navy Euro 3	'08	ISON183	5,39
125	Vespa LX	'05→'06	ISON183	5,39
125	Vespa LX 4T 3V IE-Touring	'12→'13	ISON183	5,39
125	Vespa LX 4T Euro 3 Touring	'10→'11	ISON183	5,39
125	Vespa LX 4T FL	'09	ISON183	5,39
125	Vespa LX Euro 3	'06→'08	ISON183	5,39
125	Vespa LX Euro 3 IE	'09→'11	ISON183	5,39
125	Vespa LX Primavera 4T 3V IE	'13→'17	ISON183	5,39
125	Vespa LXV 4T Euro 3	'06→'09	ISON183	5,39
125	Vespa LXV 4T Navy Euro 3	'07→'08	ISON183	5,39
125	Vespa LXV IE 4T	'10→'13	ISON183	5,39
125	Vespa Primavera 4T 3V Euro 4 IGET ABS	'16→'19	ISON183	5,39
125	Vespa S 4T 3V IE	'12	ISON183	5,39



FILTRI ISON / ISON FILTER

CC	Modello Model	Anno Years	Codice Code	€	CC	Modello Model	Anno Years	Codice Code	€
125	Vespa S 4T EURO 3	'07→'08	ISON183	5,39	250	Beverly Cruiser	'07→'09	ISON183	5,39
125	Vespa S 4T IE & College	'09→'11	ISON183	5,39	250	Beverly Euro 3 MIC	'07	ISON183	5,39
125	Vespa Sprint 4T 3V IE	'14→'15	ISON183	5,39	250	Beverly Ie Euro 3	'06→'08	ISON183	5,39
125	Vespa Sprint Iget 4T 3V ABS	'16→'19	ISON183	5,39	250	Beverly RST	'04→'05	ISON183	5,39
125	X EVO	'07→'16	ISON183	5,39	250	Beverly Sport	'06→'08	ISON183	5,39
125	X10 4T 4V IE Euro 3	'12→'15	ISON183	5,39	250	Beverly Tourer Euro 3	'07→'09	ISON183	5,39
125	X7 EURO 3	'08	ISON183	5,39	250	Carnaby	'08→'09	ISON183	5,39
125	X7 EVO IE Euro 3	'09→'10	ISON183	5,39	250	MP3	'06→'08	ISON183	5,39
125	X8	'04→'04	ISON183	5,39	250	MP3 LT	'08→'09	ISON183	5,39
125	X8	'05→'06	ISON183	5,39	250	MP3 MIC	'08→'09	ISON183	5,39
125	X8 Premium Euro 2	'06→'06	ISON183	5,39	250	Vespa GT 60 Euro 3	'06→'07	ISON183	5,39
125	X8 Premium Euro 3	'06→'07	ISON183	5,39	250	Vespa GTS	'05→'14	ISON183	5,39
125	X8 Street Euro 2	'06→'07	ISON183	5,39	250	Vespa GTS ABS	'05→'12	ISON183	5,39
125	X9	'01→'02	ISON183	5,39	250	Vespa GTV	'06→'09	ISON183	5,39
125	X9 Evolution	'03	ISON183	5,39	250	Vespa GTV 4T Navy Euro 3	'07	ISON183	5,39
125	X9 Evolution	'05→'06	ISON183	5,39	250	X EVO	'07→'13	ISON183	5,39
125	X9 Evolution Euro 3	'07	ISON183	5,39	250	X7 Euro 3	'08	ISON183	5,39
125	ZIP	'00→'02	ISON183	5,39	250	X8 Euro 3	'05→'08	ISON183	5,39
150	Fly	'05→'07	ISON183	5,39	250	X9 Evolution	'04	ISON183	5,39
150	Fly Euro 3	'08→'11	ISON183	5,39	250	X9 Evolution	'06	ISON183	5,39
150	Liberty 4T 3V LEM	'13→'14	ISON183	5,39	300	Beverly IE ABS Euro 4	'16→'19	ISON183	5,39
150	Liberty 4T Euro 3	'08	ISON183	5,39	300	Beverly RST 4T 4V IE Euro 3	'10→'16	ISON183	5,39
150	Liberty 4T Sport Euro 3	'08	ISON183	5,39	300	Beverly Tourer Euro 3	'09→'10	ISON183	5,39
150	Liberty Iget 4T 3V IE	'15→'19	ISON183	5,39	300	Carnaby Cruiser	'09→'12	ISON183	5,39
150	Liberty MOC 4T Euro 3	'09→'13	ISON183	5,39	300	MP3 4T 4V IE ERL Ibrido	'10→'13	ISON183	5,39
150	Medley 4T IE ABS	'16→'20	ISON183	5,39	300	MP3 4T 4V IE LT Ibrido	'10→'11	ISON183	5,39
150	Medley S 4T IE ABS	'16→'20	ISON183	5,39	300	MP3 HPE Euro 4 ABS-Sport	'19	ISON183	5,39
150	Vespa ET4	'99→'02	ISON183	5,39	300	MP3 IE Euro 4 LT Business Sport ABS	'16→'18	ISON183	5,39
150	Vespa GTS 4T Euro 4 ABS	'16→'17	ISON183	5,39	300	MP3 IE LT	'10→'11	ISON183	5,39
150	Vespa GTS Super IE 4T 3V	'14→'15	ISON183	5,39	300	MP3 IE LT- IE LT Sport	'11→'14	ISON183	5,39
150	Vespa LT 4T 3V IE	'14	ISON183	5,39	300	MP3 IE LT Touring	'11→'13	ISON183	5,39
150	Vespa LX	'05→'06	ISON183	5,39	300	MP3 IE MIC	'10	ISON183	5,39
150	Vespa LX 4T 3V IE-Touring	'12→'13	ISON183	5,39	300	MP3 IE MIC	'11	ISON183	5,39
150	Vespa LX 4T FL	'09	ISON183	5,39	300	MP3 IE touring	'11→'12	ISON183	5,39
150	Vespa LX Euro 3	'06→'08	ISON183	5,39	300	MP3 LT Business-Sport ABS Enjoy	'14→'16	ISON183	5,39
150	Vespa LX Euro 3 IE	'09→'11	ISON183	5,39	300	MP3 Yourban ERL	'11→'15	ISON183	5,39
150	Vespa LX Touring	'10→'12	ISON183	5,39	300	MP3 Yourban LT ERL	'11→'16	ISON183	5,39
150	Vespa Primavera 4T 3V Iget ABS	'16→'19	ISON183	5,39	300	MP3 Yourban LT RL Euro 4	'17→'18	ISON183	5,39
150	Vespa Primavera 4T-3V	'13→'16	ISON183	5,39	300	Vespa GTS - GTS Super IE ABS Euro 4	'16→'18	ISON183	5,39
150	Vespa S 4T	'08→'09	ISON183	5,39	300	Vespa GTS HPE 4T/4V IE ABS Euro 4	'19	ISON183	5,39
150	Vespa S 4T IE & College	'09→'12	ISON183	5,39	300	Vespa GTS IE & Touring	'12→'16	ISON183	5,39
150	Vespa Sprint 4T 3V IE	'15	ISON183	5,39	300	Vespa GTS IE Touring	'11→'12	ISON183	5,39
150	Vespa Sprint Sport 4T 3V Iget ABS	'16→'19	ISON183	5,39	300	Vespa GTS Super	'08→'16	ISON183	5,39
150	X8 Street Euro 2	'06→'08	ISON183	5,39	300	Vespa GTS Super HPE 4T/4V IE ABS	'18→'19	ISON183	5,39
180	Hexagon GTX	'00	ISON183	5,39	300	Vespa GTS Super Sport	'10→'13	ISON183	5,39
180	Super Hexagon GTX 12"	'01→'02	ISON183	5,39	300	Vespa GTV 4T 4V IE	'10→'13	ISON183	5,39
180	X9 Amalfi	'00→'03	ISON183	5,39	300	Vespa GTV Sei Giorni IE Euro 4 ABS	'17→'17	ISON183	5,39
200	APE Calessino (CITY)	'13→'17	ISON183	5,39	300	Vespa GTV Sei Giorni IE Euro 4 ABS	'19→'20	ISON183	5,39
200	APE Calessino Euro 4	'17→'19	ISON183	5,39	300	Vespa GTV Via Montenapoleone	'10	ISON183	5,39
200	Carnaby	'07→'08	ISON183	5,39	300	X7 EVO IE Euro 3	'09→'12	ISON183	5,39
200	Liberty	'06	ISON183	5,39	350	Beverly 4T ST IE ABS	'16→'19	ISON563	8,31
200	Liberty 4T Euro 3	'06→'08	ISON183	5,39	350	MP3 Maxi Sport Euro 4 ABS	'18→'19	ISON183	5,39
200	Liberty 4T Sport Euro 3	'06→'07	ISON183	5,39	350	X10 4T 4V IE Euro 3	'12→'15	ISON183	5,39
200	Liberty RST	'04→'04	ISON183	5,39	400	Beverly Euro 3	'06→'07	ISON184	6,41
200	Liberty Sport	'06→'06	ISON183	5,39	400	Beverly Tourer Euro 3	'08→'10	ISON184	6,41
200	Vespa Granturismo	'06→'07	ISON183	5,39					
200	X8	'05→'07	ISON183	5,39					
200	X9	'02→'03	ISON183	5,39					
200	X9 Evolution	'03	ISON183	5,39					
250	Beverly	'05→'07	ISON183	5,39					



FILTRI ISON / ISON FILTER

CC	Modello Model	Anno Years	Codice Code	€
400	MP3	'07→'08	ISON184	6,41
400	MP3 IE LT-MP3 IE LT Sport	'08→'10	ISON184	6,41
400	MP3 IE LT Touring	'11	ISON184	6,41
400	MP3 MIC	'08→'10	ISON184	6,41
400	MP3 RL Touring	'11	ISON184	6,41
400	X EVO	'07→'11	ISON184	6,41
400	X8 Euro 3	'06→'08	ISON184	6,41
500	Beverly	'02→'04	ISON184	6,41
500	Beverly	'05→'06	ISON184	6,41
500	Beverly Cruiser	'07→'12	ISON184	6,41
500	Beverly Euro 3	'06→'08	ISON184	6,41
500	MP3 IE	'07→'08	ISON184	6,41
500	MP3 IE Tourer	'10	ISON184	6,41
500	MP3 LT Business ABS	'14→'18	ISON184	6,41
500	MP3 LT Euro 4 Sport-Business	'16→'18	ISON184	6,41
500	MP3 LT Sport-Business	'11→'13	ISON184	6,41
500	MP3 Maxi Sport-Business Euro 4 ABS	'18→'18	ISON184	6,41
500	MP3 RL Sport-Business	'11→'12	ISON184	6,41
500	MP3 Sport ABS	'14→'16	ISON184	6,41
500	X10 4T 4V IE Euro 3	'12→'14	ISON184	6,41
500	X9 Evolution	'03→'05	ISON184	6,41
500	X9 Evolution	'06→'07	ISON184	6,41
500	X9 Evolution ABS	'06→'07	ISON184	6,41

POLARIS

300	Hawkeye	'06	ISON303	8,06
300	Hawkeye	'06	ISON303	8,06
300	Hawkeye	'07	ISON303	8,06
300	Hawkeye	'08→'09	ISON303	8,06
300	Hawkeye	'10→'12	ISON303	8,06
300	Hawkeye	'07→'11	ISON303	8,06
300	Hawkeye	'07→'11	ISON303	8,06
300	Sportsman	'08→'10	ISON303	8,06
300	Sportsman	'08→'10	ISON116	3,89
325	Magnum	'00	ISON303	8,06
325	Magnum	'02	ISON303	8,06
325	Magnum	'02	ISON303	8,06
325	Magnum Mose	'01	ISON303	8,06
325	Trail Boss	'00→'02	ISON303	8,06
325	Xpedition	'00→'02	ISON303	8,06
330	ATP	'04→'05	ISON303	8,06
330	Hawkeye	'06	ISON303	8,06
330	Magnum	'03→'05	ISON303	8,06
330	Magnum	'03→'06	ISON303	8,06
330	Trail Blazer	'08→'11	ISON303	8,06
330	Trail Boss	'03→'11	ISON303	8,06
335	Sportsman	'99→'00	ISON303	8,06
335	Sportsman/Worker	'99→'00	ISON303	8,06
400	Hawkeye	'11	ISON303	8,06
400	Ho Hawkeye	'11→'14	ISON303	8,06
400	Ranger	'10→'14	ISON303	8,06
400	Sportsman	'01→'05	ISON303	8,06
400	Sportsman	'08→'11	ISON303	8,06
425	Magnum	'95→'98	ISON303	8,06
425	Magnum	'95→'98	ISON303	8,06
425	Magnum	'96→'97	ISON303	8,06
425	Ranger	'01→'03	ISON303	8,06
425	Xpedition	'00→'02	ISON303	8,06
450	MXR Outlaw	'09→'10	ISON155	5,50
450	MXR Outlaw	'09→'10	ISON157	5,67

CC	Modello Model	Anno Years	Codice Code	€
450	S Outlaw	'08→'10	ISON155	5,50
450	S Outlaw	'08→'10	ISON157	5,67
450	Sportsman	'06→'07	ISON303	8,06
455	Diesel	'99→'00	ISON303	8,06
455	Diesel	'01	ISON303	8,06
500	ATP HO	'04→'05	ISON303	8,06
500	Big Boss	'98→'99	ISON303	8,06
500	Big Boss	'98→'99	ISON303	8,06
500	EFI HO Ranger	'09→'13	ISON303	8,06
500	EFI Ranger	'06→'08	ISON303	8,06
500	EFI/HO Sportsman	'07→'08	ISON303	8,06
500	HO EFI Sportsman	'08→'11	ISON303	8,06
500	HO Sportsman Touring	'08→'10	ISON303	8,06
500	HO/EFI Sportsman	'04→'06	ISON303	8,06
500	HO/EFI Sportsman Demand Drive	'03→'04	ISON303	8,06
500	Magnum	'99→'00	ISON303	8,06
500	Magnum	'01	ISON303	8,06
500	Magnum	'02	ISON303	8,06
500	Magnum	'02	ISON303	8,06
500	Outlaw	'06→'07	ISON112	3,34
500	Ranger	'06→'07	ISON303	8,06
500	Ranger	'08→'09	ISON303	8,06
500	Ranger CREW	'11→'13	ISON303	8,06
500	Ranger Series 10	'0	ISON303	8,06
500	Scrambler	'97→'04	ISON303	8,06
500	Scrambler	'00→'09	ISON303	8,06
500	Scrambler	'07→'08	ISON303	8,06
500	Scrambler	'10→'11	ISON303	8,06
500	Sportsman	'96→'97	ISON303	8,06
500	Sportsman	'01→'08	ISON303	8,06
500	Sportsman/Worker	'98→'02	ISON303	8,06
500	TLD Predator	'03→'07	ISON112	3,34
500	X2 EFI Sportsman	'07→'08	ISON303	8,06
500	X2 Sportsman	'06→'09	ISON303	8,06
500	XP Sportsman	'09→'09	ISON303	8,06
500	Xplorer	'97	ISON303	8,06
525	IRS Outlaw	'08→'11	ISON155	5,50
525	IRS Outlaw	'08→'11	ISON157	5,67
525	S Outlaw	'08→'10	ISON155	5,50
525	S Outlaw	'08→'10	ISON157	5,67
570	Ranger Crew	'14→'15	ISON198	7,96
570	RZR Ranger	'12→'20	ISON198	7,96
570	Sportsman ACE	'15→'20	ISON198	7,96
570	Sportsman ACE Euro	'15→'20	ISON198	7,96
600	Sportsman	'04→'05	ISON198	7,96
700	EFI Le Ranger	'07→'07	ISON198	7,96
700	EFI Ranger	'06→'09	ISON198	7,96
700	EFI Ranger	'08	ISON198	7,96
700	EFI Ranger	'09	ISON198	7,96
700	EFI Sportsman	'04→'06	ISON198	7,96
700	EFI Sportsman	'07	ISON198	7,96
700	X2 Sportsman	'08	ISON198	7,96
700	XP Ranger	'06	ISON198	7,96
700	XP Ranger	'08	ISON198	7,96
800	EFI Sportsman	'05→'14	ISON198	7,96
800	EFI Sportsman Touring	'08→'09	ISON198	7,96
800	HD Ranger	'10→'11	ISON198	7,96
800	HO EFI Sportsman	'07→'11	ISON198	7,96
800	Ranger	'10→'14	ISON198	7,96
800	Ranger CREW	'10→'14	ISON198	7,96
800	RZR Ranger	'08→'14	ISON198	7,96



FILTRI ISON / ISON FILTER

CC	Modello Model	Anno Years	Codice Code	€
800	RZR S EFI Ranger	'09→'14	ISON198	7,96
800	RZR-4 Ranger	'10→'14	ISON198	7,96
800	Sportsman	'09→'14	ISON198	7,96
800	Sportsman Big Boss	'11→'13	ISON198	7,96
800	X2 Sportsman	'07→'09	ISON198	7,96
800	XP Ranger	'10v11	ISON198	7,96
900	RZR Ranger	'13	ISON198	7,96
900	XP Ranger	'13→'15	ISON198	7,96

RIEJU

125	Marathon	'09→'11	ISON141	5,56
125	RS3	'09→'11	ISON141	5,56
250	Marathon	'09→'11	ISON141	5,56
450	Marathon	'09→'10	ISON141	5,56

SACHS

800	805 B	'02	ISON138	8,06
650	Roadster	'00→'05	ISON137	4,96
800	Roadster	'00→'05	ISON138	8,06
125	Roadster	'98→'01	ISON611	6,07

SHERCO

250	SCF-R Cross Country 4T	'19→'20	ISON611	6,07
250	SE I F	'08→'15	ISON611	6,07
250	SEF-R Enduro Factory 4T	'17→'20	ISON611	6,07
250	SEF-R Enduro Racing 4T	'14→'20	ISON611	6,07
250	SX 2.5 I F Moto Cross	'10	ISON611	6,07
300	SCF-R Cross Country 4T	'19→'20	ISON611	6,07
300	SE I	'10→'15	ISON611	6,07
300	SEF-R Enduro Factory 4T	'17→'20	ISON611	6,07
300	SEF-R Enduro Racing 4T	'14→'20	ISON611	6,07
450	SCF-R Cross Country	'19→'20	ISON611	6,07
450	SE I F	'04→'15	ISON611	6,07
450	SEF-R Enduro Factory	'17→'20	ISON611	6,07
450	SEF-R Enduro Racing	'15→'20	ISON611	6,07
450	SM 4.5 I F	'04→'10	ISON611	6,07
500	SCF-R Cross Country	'19→'20	ISON611	6,07
500	SEF-R Enduro Factory	'19→'20	ISON611	6,07
500	SEF-R Enduro Racing	'19→'20	ISON611	6,07
510	SE 5.1 I-F Enduro	'04→'13	ISON611	6,07
510	SM 5.1 I F	'04→'10	ISON611	6,07

SUZUKI

90	LT-Z QuadSport	'07→'16	ISON131	3,64
110	DR-Z	'03→'05	ISON112	3,34
125	AN	'95→'00	ISON971	2,78
125	CS	'83	ISON131	3,64
125	DR S	'82→'84	ISON131	3,64
125	DR S	'85→'94	ISON132	3,34
125	DR SE	'94→'01	ISON132	3,34
125	DR SM	'08→'13	ISON131	3,64
125	DR-Z L	'03→'20	ISON132	3,34
125	FL SDW Address	'07→'10	ISON207	4,54
125	GN	'82→'90	ISON131	3,64
125	GN	'94→'01	ISON131	3,64
125	GN E	'94→'01	ISON131	3,64
125	GS	'82→'84	ISON131	3,64
125	GS ES	'82→'00	ISON131	3,64
125	LT	'83→'87	ISON131	3,64

CC	Modello Model	Anno Years	Codice Code	€
125	RV Van-Van	'02→'17	ISON132	3,34
125	TU X	'99	ISON131	3,64
125	UC	'99→'02	ISON971	2,78
125	UE CT	'01→'03	ISON971	2,78
125	UH Burgman	'02→'16	ISON971	2,78
125	UH Burgman ABS	'14→'20	ISON971	2,78
125	UX Sixteen	'08→'13	ISON971	2,78
125	VL Intruder	'99→'08	ISON136	4,89
150	UE CT	'01→'01	ISON971	2,78
150	UH Burgman	'02→'06	ISON971	2,78
150	UX Sixteen	'08→'13	ISON971	2,78
160	LT	'03→'04	ISON132	3,34
160	LT-F	'90→'04	ISON132	3,34
185	LT	'84→'85	ISON131	3,64
200	DR	'86→'89	ISON132	3,34
200	DR SE	'93→'13	ISON132	3,34
200	RV Van-Van	'16→'19	ISON132	3,34
200	UH Burgman	'07→'16	ISON971	2,78
200	UH Burgman ABS	'14→'20	ISON971	2,78
230	LT GE	'85→'86	ISON132	3,34
230	LT S	'85→'88	ISON132	3,34
230	LT-F	'86→'87	ISON132	3,34
250	AN Burgman	'98→'02	ISON972	2,78
250	DL V-Strom	'17→'20	ISON138	8,06
250	DR	'90→'93	ISON136	4,89
250	DR S	'82→'92	ISON136	4,89
250	DR SE	'93→'95	ISON136	4,89
250	DR-Z	'01→'07	ISON136	4,89
250	GN	'85→'97	ISON136	4,89
250	GS T	'80→'81	ISON133	5,91
250	GSX E Katana	'80→'82	ISON133	5,91
250	GSX-R	'17→'20	ISON138	8,06
250	GSX-R C	'88→'89	ISON133	5,91
250	GSX-R R	'89	ISON133	5,91
250	GW Inazuma	'13→'15	ISON138	8,06
250	GZ Marauder	'02→'08	ISON136	4,89
250	LT EF	'85→'86	ISON132	3,34
250	LT-F	'87→'98	ISON132	3,34
250	LT-F	'88→'01	ISON132	3,34
250	LT-F F	'99→'02	ISON132	3,34
250	LT-F Ozark	'02→'14	ISON132	3,34
250	LT-Z QuadSport	'04→'10	ISON132	3,34
250	RM-Z	'04→'20	ISON207	4,54
250	TU X	'97→'03	ISON136	4,89
250	VL Intruder	'00→'07	ISON136	4,89
300	LT-F	'88→'98	ISON132	3,34
300	LT-F F	'99→'02	ISON132	3,34
350	DR S	'90→'93	ISON136	4,89
350	DR SE	'94→'99	ISON136	4,89
350	SG Goose	'92→'92	ISON136	4,89
400	AN Burgman	'99→'00	ISON972	2,78
400	AN Burgman	'01→'06	ISON972	2,78
400	AN Burgman	'07→'15	ISON971	2,78
400	AN Burgman ABS	'07→'20	ISON971	2,78
400	AN Burgman Executive	'09→'16	ISON971	2,78
400	AN Burgman Executive ABS	'09→'19	ISON971	2,78
400	DR S	'80→'81	ISON136	4,89
400	DR-Z	'00→'07	ISON139	4,26
400	DR-Z E	'00→'07	ISON139	4,26
400	DR-Z S	'00→'14	ISON139	4,26
400	DR-Z SE	'01	ISON139	4,26
400	DR-Z SM	'05→'09	ISON139	4,26



FILTRI ISON / ISON FILTER

CC	Modello Model	Anno Years	Codice Code	€	CC	Modello Model	Anno Years	Codice Code	€
400	GS	'77→'78	ISON133	5,91	650	DR SE	'96→'06	ISON137	4,96
400	GSF Bandit	'89→'97	ISON133	5,91	650	GR	'83→'85	ISON133	5,91
400	GSX E	'80→'82	ISON133	5,91	650	GS G Katana	'81→'83	ISON133	5,91
400	GSX E-S	'82→'87	ISON133	5,91	650	GSF N Bandit	'05→'15	ISON138	8,06
400	GSX F	'81→'85	ISON133	5,91	650	GSF N Bandit ABS	'05→'15	ISON138	8,06
400	GSX F	'88→'90	ISON133	5,91	650	GSF S Bandit	'05→'13	ISON138	8,06
400	GSX T	'83	ISON133	5,91	650	GSF S Bandit ABS	'05→'15	ISON138	8,06
400	GSX-R	'87→'88	ISON133	5,91	650	GSX- F	'08→'16	ISON138	8,06
400	GSX-R R	'90→'92	ISON138	8,06	650	GSX- F ABS	'08→'15	ISON138	8,06
400	LT-A F Eiger	'02→'07	ISON138	8,06	650	LS F Savage	'86→'99	ISON137	4,96
400	LT-F Eiger	'02→'07	ISON138	8,06	650	SFV Gladius	'09→'16	ISON138	8,06
400	LT-F F Eiger	'02→'07	ISON138	8,06	650	SFV Gladius ABS	'09→'16	ISON138	8,06
400	LT-Z	'02→'18	ISON139	4,26	650	SV ABS	'16→'20	ISON138	8,06
400	SP	'80	ISON136	4,89	650	SV N	'99→'10	ISON138	8,06
425	GS	'79→'80	ISON133	5,91	650	SV N ABS	'07→'10	ISON138	8,06
450	GS E	'80→'88	ISON133	5,91	650	SV S	'99→'11	ISON138	8,06
450	GS L	'80→'87	ISON133	5,91	650	SV S ABS	'07→'10	ISON138	8,06
450	LT-A X Kingquad	'07→'10	ISON138	8,06	650	SV X ABS	'18→'20	ISON138	8,06
450	LT-R Quadracer	'06→'06	ISON138	8,06	650	XF Freewind	'97→'02	ISON137	4,96
450	LT-R Quadracer	'07→'12	ISON139	4,26	700	GS E	'85	ISON133	5,91
450	LT-R Quadracer	'11	ISON139	4,26	700	LT-A X King Quad	'05→'07	ISON138	8,06
450	RM-X Z	'10→'17	ISON207	4,54	700	LT-V F Twin Peaks	'04→'05	ISON204	8,06
450	RM-Z	'05→'20	ISON207	4,54	750	DR S	'88→'89	ISON137	4,96
500	DR	'81→'83	ISON137	4,96	750	GS	'77	ISON133	5,91
500	DR S	'84	ISON137	4,96	750	GS D	'77→'78	ISON133	5,91
500	GS	'01→'07	ISON133	5,91	750	GS E	'78→'79	ISON133	5,91
500	GS E	'89→'00	ISON133	5,91	750	GSR	'11→'16	ISON138	8,06
500	GS F	'04→'08	ISON133	5,91	750	GSR ABS	'11→'17	ISON138	8,06
500	LT-A F	'02→'07	ISON138	8,06	750	GSX E	'80→'82	ISON133	5,91
500	LT-A F Quad Master	'00→'01	ISON138	8,06	750	GSX EF	'84→'85	ISON133	5,91
500	LT-A XP	'10→'20	ISON138	8,06	750	GSX ES	'83→'89	ISON133	5,91
500	LT-F F	'98→'02	ISON138	8,06	750	GSX F	'89→'06	ISON138	8,06
500	LT-F F Vinson Quadrunner	'03→'07	ISON138	8,06	750	GSX Inazuma	'98→'03	ISON138	8,06
550	GS D	'77→'78	ISON133	5,91	750	GSX S	'84	ISON133	5,91
550	GS E	'78→'82	ISON133	5,91	750	GSX S2 Katana	'84→'85	ISON133	5,91
550	GS L	'80→'81	ISON133	5,91	750	GSX-R	'88→'91	ISON138	8,06
550	GS M	'81→'82	ISON133	5,91	750	GSX-R	'96→'99	ISON138	8,06
550	GSX EF	'84→'86	ISON133	5,91	750	GSX-R	'00→'17	ISON138	8,06
550	GSX ES	'83→'84	ISON133	5,91	750	GSX-R R	'88→'89	ISON138	8,06
550	GSX ES	'87	ISON133	5,91	750	GSX-R R SP	'92→'95	ISON138	8,06
600	DR R Dakar	'86→'89	ISON137	4,96	750	GSX-R W	'92→'95	ISON138	8,06
600	DR S	'85→'89	ISON137	4,96	750	GSX-S	'15	ISON138	8,06
600	GSF Bandit	'95→'04	ISON138	8,06	750	GSX-S ABS	'15→'20	ISON138	8,06
600	GSF Bandit S	'96→'04	ISON138	8,06	750	LT-A X King Quad	'08→'13	ISON138	8,06
600	GSR	'06→'10	ISON138	8,06	750	LT-A XP	'09→'19	ISON138	8,06
600	GSX F	'88→'06	ISON138	8,06	750	VS GLEF Intruder	'87	ISON138	8,06
600	GSX-R	'97→'17	ISON138	8,06	750	VS GLEP Intruder	'87	ISON138	8,06
600	RF R	'93→'97	ISON138	8,06	750	VS GLF Intruder	'86→'87	ISON138	8,06
600	VS GL Intruder	'95→'97	ISON138	8,06	750	VS GLP Intruder	'86→'91	ISON138	8,06
650	AN Burgman	'02→'17	ISON975	6,42	800	DR S	'89→'96	ISON137	4,96
650	AN Burgman ABS	'17→'18	ISON975	6,42	800	VL C Intruder	'07→'14	ISON138	8,06
650	AN Burgman Executive ABS	'04→'12	ISON975	6,42	800	VL Intruder	'05→'17	ISON138	8,06
650	AN Burgman Executive ABS	'13→'20	ISON975	6,42	800	VL Intruder Volusia	'01→'04	ISON138	8,06
650	DL V-Strom	'04→'06	ISON138	8,06	800	VS GL Intruder	'92→'99	ISON138	8,06
650	DL V-Strom ABS	'07→'20	ISON138	8,06	800	VX	'90→'96	ISON138	8,06
650	DL V-Strom Traveller ABS	'07→'11	ISON138	8,06	800	VZ Intruder	'05→'17	ISON138	8,06
650	DL V-Strom Xpedition ABS	'11→'11	ISON138	8,06	800	VZ Marauder	'97→'04	ISON138	8,06
650	DL X V-Strom	'07→'11	ISON138	8,06	800	VZ Z Intruder	'09→'10	ISON138	8,06
650	DL X V-Strom XT ABS	'15→'20	ISON138	8,06	850	GS G	'79→'86	ISON133	5,91
650	DR R	'90→'93	ISON137	4,96	900	RF R	'94→'99	ISON138	8,06
650	DR RE	'94→'95	ISON137	4,96	1000	DL V-Strom	'02→'11	ISON138	8,06
650	DR RS	'90→'91	ISON137	4,96	1000	DL V-Strom ABS	'14→'20	ISON138	8,06
650	DR RSE	'91→'93	ISON137	4,96	1000	DL X V-Strom XT ABS	'17→'20	ISON138	8,06



FILTRI ISON / ISON FILTER

CC	Modello Model	Anno Years	Codice Code	€
1000	GS E	'78→'80	ISON133	5,91
1000	GS G	'80→'81	ISON133	5,91
1000	GS H	'78→'78	ISON133	5,91
1000	GS S	'79	ISON133	5,91
1000	GSX S Katana	'82	ISON133	5,91
1000	GSX-R	'01→'18	ISON138	8,06
1000	GSX-R	'17→'20	ISON138	8,06
1000	GSX-R ABS	'15→'16	ISON138	8,06
1000	GSX-R R	'17→'20	ISON138	8,06
1000	GSX-S	'15→'17	ISON138	8,06
1000	GSX-S ABS	'15→'20	ISON138	8,06
1000	GSX-S EVO ABS	'18→'18	ISON138	8,06
1000	GSX-S F	'15→'17	ISON138	8,06
1000	GSX-S F	'18	ISON138	8,06
1000	GSX-S F ABS	'15→'20	ISON138	8,06
1000	Katana	'19→'20	ISON138	8,06
1000	Katana S	'20	ISON138	8,06
1000	SV N	'03→'07	ISON138	8,06
1000	SV S	'03→'07	ISON138	8,06
1000	TL R	'98→'02	ISON138	8,06
1000	TL S	'97→'01	ISON138	8,06
1050	DL V-Strom	'20	ISON138	8,06
1050	DL V-Strom XT	'20	ISON138	8,06
1100	GS G	'82	ISON133	5,91
1100	GSX E	'80→'82	ISON133	5,91
1100	GSX EF	'84→'85	ISON133	5,91
1100	GSX ES	'83→'84	ISON133	5,91
1100	GSX F	'87→'94	ISON138	8,06
1100	GSX G	'91→'96	ISON138	8,06
1100	GSX S Katana	'82→'83	ISON133	5,91
1100	GSX-R	'86→'92	ISON138	8,06
1100	GSX-R W	'93→'98	ISON138	8,06
1200	GSF Bandit ABS	'06→'06	ISON138	8,06
1200	GSF N Bandit	'96→'06	ISON138	8,06
1200	GSF S Bandit	'96→'06	ISON138	8,06
1200	GSF S Bandit ABS	'97→'06	ISON138	8,06
1200	GSX FS Inazuma	'98→'00	ISON138	8,06
1250	GSF N Bandit	'07→'12	ISON138	8,06
1250	GSF N Bandit ABS	'07→'11	ISON138	8,06
1250	GSF S Bandit	'07→'10	ISON138	8,06
1250	GSF S Bandit ABS	'07→'16	ISON138	8,06
1250	GSX F ABS	'10→'16	ISON138	8,06
1250	GSX F ST Traveller ABS	'10→'16	ISON138	8,06
1300	B-King GSX	'08→'12	ISON138	8,06
1300	GSX-R Hayabusa	'99→'07	ISON138	8,06
1300	GSX-R Hayabusa	'08→'12	ISON138	8,06
1300	GSX-R Hayabusa ABS	'13→'17	ISON138	8,06
1400	GSX	'01→'07	ISON138	8,06
1400	VS GL Intruder	'87→'03	ISON138	8,06
1500	VL Intruder	'05→'17	ISON138	8,06
1500	VL Intruder Legendry Classic	'98→'03	ISON138	8,06
1600	VZ Marauder	'04→'05	ISON204	8,06
1800	VLR Intruder	'08→'11	ISON138	8,06
1800	VLR RT Intruder	'08→'09	ISON138	8,06
1800	VZR BZ Intruder	'14→'17	ISON138	8,06
1800	VZR R Intruder	'06→'17	ISON138	8,06
1800	VZR R2N Intruder	'08→'09	ISON138	8,06
1800	VZR RZ	'07→'13	ISON138	8,06

SYM

400	Maxsym I	'11→'16	ISON132	3,34
400	Maxsym I ABS	'17→'20	ISON132	3,34

CC	Modello Model	Anno Years	Codice Code	€
TGB				
400	Avenger	'07→'10	ISON148	11,93
400	Target	'06→'10	ISON148	11,93
425	Blade	'08→'10	ISON148	11,93
425	Outback	'03→'15	ISON148	11,93
425	Target	'08→'09	ISON148	11,93
500	Blade R	'10→'14	ISON148	11,93
500	Target	'10→'14	ISON148	11,93
525	Blade	'09→'14	ISON148	11,93
525	Target	'08→'10	ISON148	11,93
550	Blade LT	'09→'14	ISON148	11,93
550	Target	'12→'16	ISON148	11,93

TM

250	EN-F	'03→'07	ISON142	8,72
250	MX-F	'03→'07	ISON142	8,72
250	EN-F	'08→'10	ISON141	5,56
250	MX-F	'08→'18	ISON141	5,56
250	SMM-F	'10→'14	ISON141	5,56
250	SMR F	'10→'14	ISON141	5,56
250	EN FI Enduro	'11→'20	ISON141	5,56
300	EN FI Enduro	'17→'20	ISON141	5,56
450	SMR-F	'05→'11	ISON142	8,72
450	SMX-F	'05→'11	ISON142	8,72
450	EN-F	'07→'10	ISON142	8,72
450	MX-F	'07→'12	ISON142	8,72
450	SMM-F Black Dream	'08→'10	ISON142	8,72
450	SMM-F	'11→'15	ISON142	8,72
450	EN-F	'11→'18	ISON141	5,56
450	SMR-F	'12→'18	ISON141	5,56
450	SMX-F	'12→'18	ISON141	5,56
450	MX-F	'13→'18	ISON141	5,56
530	SMR-F	'07→'09	ISON141	5,56
530	SMX-F	'07→'11	ISON141	5,56
530	MX-F	'07→'18	ISON141	5,56
530	SMM-F Black Dream	'09→'10	ISON141	5,56
530	SMR-F	'10→'11	ISON141	5,56
660	SMX-F Competition	'03→'06	ISON142	8,72

TRIUMPH

600	Daytona	'03→'04	ISON204	8,06
600	Speed Four	'02→'05	ISON204	8,06
600	TT	'00→'03	ISON204	8,06
650	Daytona	'05	ISON204	8,06
675	Daytona	'06→'13	ISON204	8,06
675	Daytona ABS	'13→'17	ISON204	8,06
675	Daytona R	'11→'12	ISON204	8,06
675	Daytona R ABS	'13→'17	ISON204	8,06
675	Street Triple	'07→'13	ISON204	8,06
675	Street Triple ABS	'13→'17	ISON204	8,06
675	Street Triple R	'09→'13	ISON204	8,06
675	Street Triple R ABS	'13→'16	ISON204	8,06
675	Street Triple RX ABS	'15→'16	ISON204	8,06
750	Daytona	'91→'92	ISON401	5,81
750	Speed Triple	'97→'97	ISON401	5,81
750	Trident	'91→'98	ISON401	5,81
765	Street Triple R	'17→'19	ISON204	8,06
765	Street Triple RS	'17→'19	ISON204	8,06
765	Street Triple S	'17→'19	ISON204	8,06
800	Bonneville	'01→'06	ISON204	8,06
800	Bonneville America	'02→'07	ISON204	8,06



FILTRI ISON / ISON FILTER

CC	Modello Model	Anno Years	Codice Code	€	CC	Modello Model	Anno Years	Codice Code	€
800	Bonneville T100	'02→'06	ISON204	8,06	955	Tiger I	'04→'06	ISON204	8,06
800	Speedmaster	'03→'05	ISON204	8,06	1000	Daytona	'91→'92	ISON401	5,81
800	Tiger	'11→'14	ISON204	8,06	1000	Trophy	'92→'92	ISON204	8,06
800	Tiger ABS	'11→'14	ISON204	8,06	1050	Speed Triple	'05→'16	ISON204	8,06
800	Tiger XC	'11→'14	ISON204	8,06	1050	Speed Triple 94 ABS	'15→'16	ISON204	8,06
800	Tiger XC ABS	'11→'20	ISON204	8,06	1050	Speed Triple ABS	'07→'16	ISON204	8,06
800	Tiger XCA ABS	'15→'20	ISON204	8,06	1050	Speed Triple R	'12→'16	ISON204	8,06
800	Tiger XCX ABS	'15→'20	ISON204	8,06	1050	Speed Triple R 94 ABS	'15→'16	ISON204	8,06
800	Tiger XR ABS	'15→'20	ISON204	8,06	1050	Speed Triple R ABS	'12→'17	ISON204	8,06
800	Tiger XRT ABS	'15→'20	ISON204	8,06	1050	Speed Triple RS ABS	'18→'20	ISON204	8,06
800	Tiger XRX ABS	'15→'20	ISON204	8,06	1050	Speed Triple S ABS	'16→'20	ISON204	8,06
855	T309 Speed Triple	'94→'97	ISON401	5,81	1050	Speed Triple T ABS	'12→'14	ISON204	8,06
865	America	'07	ISON204	8,06	1050	Sprint GT ABS	'10→'16	ISON204	8,06
865	America EFI	'08→'17	ISON204	8,06	1050	Sprint I ST	'11→'12	ISON204	8,06
865	America LT EFI	'14→'17	ISON204	8,06	1050	Sprint I ST ABS	'11→'12	ISON204	8,06
865	Bonneville	'07	ISON204	8,06	1050	Sprint ST	'05→'10	ISON204	8,06
865	Bonneville Black	'07→'08	ISON204	8,06	1050	Sprint ST ABS	'05→'10	ISON204	8,06
865	Bonneville EFI	'08→'16	ISON204	8,06	1050	Tiger ABS	'07→'12	ISON204	8,06
865	Bonneville EFI Newchurch	'15→'16	ISON204	8,06	1050	Tiger SE ABS	'10→'13	ISON204	8,06
865	Bonneville EFI T100	'08→'15	ISON204	8,06	1050	Tiger Sport ABS	'13→'18	ISON204	8,06
865	Bonneville EFI T100 Black	'14→'15	ISON204	8,06	1200	Bonneville Bobber	'17→'19	ISON204	8,06
865	Bonneville EFI T100 Spirit Edition	'15	ISON204	8,06	1200	Bonneville Bobber Black	'18→'19	ISON204	8,06
865	Bonneville EFI T100 Steve MC Queen	'13	ISON204	8,06	1200	Bonneville Speedmaster ABS	'18→'19	ISON204	8,06
865	Bonneville EFI T214 Limited Editon	'13	ISON204	8,06	1200	Bonneville T120	'16→'19	ISON204	8,06
865	Bonneville SE EFI	'09→'13	ISON204	8,06	1200	Bonneville T120 Black	'16→'19	ISON204	8,06
865	Bonneville SE EFI Steve MC Queen	'12	ISON204	8,06	1200	Daytona	'93→'98	ISON401	5,81
865	Bonneville T100	'04→'13	ISON204	8,06	1200	Trophy	'91→'01	ISON401	5,81
865	Scrambler	'06→'07	ISON204	8,06	1200	Truxton	'16→'18	ISON204	8,06
865	Scrambler EFI	'08→'17	ISON204	8,06	1200	Truxton R	'16→'17	ISON204	8,06
865	Speedmaster	'05→'07	ISON204	8,06	1215	Tiger Explorer ABS	'12→'15	ISON204	8,06
865	Speedmaster EFI	'08→'17	ISON204	8,06	1215	Tiger Explorer Spoked ABS	'16	ISON204	8,06
865	Thruxton	'04→'07	ISON204	8,06	1215	Tiger Explorer XC ABS	'13→'17	ISON204	8,06
865	Thruxton ACE	'14→'15	ISON204	8,06	1215	Tiger Explorer XCA ABS	'16→'19	ISON204	8,06
865	Thruxton EFI	'08→'16	ISON204	8,06	1215	Tiger Explorer XCX ABS	'16→'19	ISON204	8,06
885	T509 Speed Triple	'97→'01	ISON204	8,06	1215	Tiger Explorer Xcx Low ABS	'16→'19	ISON204	8,06
900	Adventurer	'97→'00	ISON401	5,81	1215	Tiger Explorer XR ABS	'16→'19	ISON204	8,06
900	Bonneville T100 ABS	'17→'19	ISON204	8,06	1215	Tiger Explorer XRT ABS	'16→'19	ISON204	8,06
900	Bonneville T100 Black ABS	'17→'19	ISON204	8,06	1215	Tiger Explorer XRX ABS	'16→'19	ISON204	8,06
900	Daytona	'93→'96	ISON401	5,81	1215	Tiger Explorer XRX LOW ABS	'17→'19	ISON204	8,06
900	Daytona Super III	'94→'97	ISON401	5,81	1215	Trophy ABS	'13→'16	ISON204	8,06
900	Legend TT	'99→'01	ISON401	5,81	1215	Trophy SE ABS	'13→'17	ISON204	8,06
900	Speed Triple	'94→'96	ISON401	5,81	1600	Thunderbird	'09→'13	ISON204	8,06
900	Sprint	'93→'98	ISON401	5,81	1600	Thunderbird ABS	'10→'17	ISON204	8,06
900	Street Cup	'17→'19	ISON204	8,06	1700	Thunderbird Commander	'14→'17	ISON204	8,06
900	Street Scrambler	'17→'19	ISON204	8,06	1700	Thunderbird LT	'14→'17	ISON204	8,06
900	Street Twin	'16→'19	ISON204	8,06	1700	Thunderbird Nightstorm	'15→'17	ISON204	8,06
900	Thunderbird	'96→'03	ISON401	5,81	1700	Thunderbird STORM	'11→'17	ISON204	8,06
900	Thunderbird Sport	'98→'04	ISON401	5,81	2300	Rocket III	'04→'09	ISON204	8,06
900	Tiger	'92→'93	ISON401	5,81	2300	Rocket III Classic	'06→'09	ISON204	8,06
900	Tiger	'95→'99	ISON401	5,81	2300	Rocket Iii Roadster ABS	'10→'17	ISON204	8,06
900	Tiger EFI	'98→'99	ISON401	5,81	2300	Rocket III Touring	'08→'17	ISON204	8,06
900	Trident	'92→'98	ISON401	5,81	2300	Rocket X ABS	'15→'17	ISON204	8,06
900	Trophy	'92→'01	ISON401	5,81					
955	Daytona I	'98→'06	ISON204	8,06	VICTORY				
955	Speed Triple	'02→'04	ISON204	8,06	1633	King Pin	'04→'10	ISON198	7,96
955	Sprint RS	'99→'04	ISON204	8,06	1633	King Pin Tour	'04→'07	ISON198	7,96
955	Sprint ST	'01→'04	ISON204	8,06	1633	Kingpin 8-Ball	'08→'10	ISON198	7,96
955	T595 Daytona	'97→'98	ISON204	8,06	1633	Kingpin Tour	'08→'09	ISON198	7,96
955	Tiger	'00→'04	ISON204	8,06	1633	Kingpin-Low	'09→'09	ISON198	7,96
					1633	Vegas	'03→'12	ISON198	7,96
					1633	Vegas 8-Ball	'05→'15	ISON198	7,96
					1633	Vegas Low	'08→'09	ISON198	7,96



FILTRI ISON / ISON FILTER

CC	Modello Model	Anno Years	Codice Code	€
1633	Zach Ness Vegas	'08→'12	ISON198	7,96
1731	Arlen Ness Victory Vision	'10→'12	ISON198	7,96
1731	Boardwalk	'13→'15	ISON198	7,96
1731	Cory Ness Cross Country	'11→'13	ISON198	7,96
1731	Cory Ness Jackpot	'08→'10	ISON198	7,96
1731	Cross Country	'10→'17	ISON198	7,96
1731	Cross Country 15th Anniversary	'14→'14	ISON198	7,96
1731	Cross Country 8 Ball	'15→'16	ISON198	7,96
1731	Cross Country Tour	'12→'17	ISON198	7,96
1731	Cross Country Zach Ness	'13	ISON198	7,96
1731	Cross Roads	'10→'12	ISON198	7,96
1731	Cross Roads 8 Ball	'14	ISON198	7,96
1731	Cross Roads Classic	'13→'14	ISON198	7,96
1731	Gunner	'15→'17	ISON198	7,96
1731	Hammer	'05→'11	ISON198	7,96
1731	Hammer 8 Ball	'10→'16	ISON198	7,96
1731	Hard Ball	'12→'13	ISON198	7,96
1731	High Ball	'11→'17	ISON198	7,96
1731	Jackpot	'10→'16	ISON198	7,96
1731	Judge	'12→'17	ISON198	7,96
1731	King Pin	'11→'12	ISON198	7,96
1731	Kingpin 8-Ball	'11	ISON198	7,96
1731	Magnum	'15→'17	ISON198	7,96
1731	Ness Signature Series	'05→'07	ISON198	7,96
1731	S Hammer S	'07→'17	ISON198	7,96
1731	Vegas	'08→'17	ISON198	7,96
1731	Vegas 8 Ball	'08→'17	ISON198	7,96
1731	Vegas High Ball	'12	ISON198	7,96
1731	Vegas Jackpot	'06→'07	ISON198	7,96
1731	Vision	'14→'14	ISON198	7,96
1731	Vision 10th Anniversary Ed.	'09	ISON198	7,96
1731	Vision 8 Ball	'10→'11	ISON198	7,96
1731	Vision Arlen Ness	'09→'13	ISON198	7,96
1731	Vision Street	'08→'09	ISON198	7,96
1731	Vision Street Premium	'09	ISON198	7,96
1731	Vision Tour	'08→'17	ISON198	7,96

YAMAHA

125	MT	'15→'16	ISON141	5,56
125	MT ABS	'15→'20	ISON141	5,56
125	SR	'89→'91	ISON143	7,76
125	SR	'97→'03	ISON143	7,76
125	SR SE	'82→'88	ISON143	7,76
125	SR SE	'92→'96	ISON143	7,76
125	TW	'99→'06	ISON143	7,76
125	WR R	'09→'16	ISON141	5,56
125	WR X Supermoto	'09→'16	ISON141	5,56
125	XC T Cygnus	'95	ISON143	7,76
125	XC T Cygnus	'96→'03	ISON143	7,76
125	XC TR Cygnus	'96→'03	ISON143	7,76
125	X-CITY	'08→'15	ISON141	5,56
125	X-Max	'06→'17	ISON141	5,56
125	X-Max ABS	'14→'20	ISON141	5,56
125	X-Max ABS Iron Max	'19	ISON141	5,56
125	X-Max Business ABS	'11	ISON141	5,56
125	X-Max Sport	'11→'16	ISON141	5,56
125	X-Max Tech Max	'20	ISON141	5,56
125	XT	'82→'91	ISON143	7,76
125	XV Virago	'97→'01	ISON145	4,77
125	XVS Dragstar	'00→'05	ISON145	4,77
125	YZF-R	'08→'16	ISON141	5,56
125	YZF-R ABS	'15→'20	ISON141	5,56

CC	Modello Model	Anno Years	Codice Code	€
125	YZF-R ABS	'19→'19	ISON141	5,56
135	T S Crypton X	'06→'08	ISON141	5,56
135	T SE Crypton X	'06→'08	ISON141	5,56
135	T Spark	'11→'12	ISON141	5,56
200	AG E	'93	ISON143	7,76
200	TW	'89→'94	ISON143	7,76
200	YFM N	'85	ISON143	7,76
200	YTM ELD	'89	ISON143	7,76
225	XT	'97→'06	ISON143	7,76
225	XT Sorrow	'86→'87	ISON143	7,76
225	XT Sorrow	'89→'93	ISON143	7,76
225	XT W Sorrow	'93→'98	ISON143	7,76
225	YFM	'86→'89	ISON143	7,76
225	YTM DR	'85	ISON143	7,76
230	TTR	'05→'06	ISON143	7,76
250	CP Maxam	'05→'08	ISON132	3,34
250	FZR	'87	ISON145	4,77
250	FZR R	'90	ISON145	4,77
250	SR	'91→'95	ISON145	4,77
250	SR Classic	'96→'00	ISON145	4,77
250	SR Custom	'80→'81	ISON145	4,77
250	SR SE	'81→'84	ISON145	4,77
250	SRX	'87	ISON143	7,76
250	Tricker	'04→'07	ISON141	5,56
250	TT R	'99→'04	ISON142	8,72
250	TT R USA	'99→'06	ISON142	8,72
250	WR F	'01→'02	ISON142	8,72
250	WR F	'03→'20	ISON141	5,56
250	WR R	'08→'15	ISON141	5,56
250	WR X Supermoto	'08→'15	ISON141	5,56
250	XS	'79→'81	ISON144	4,73
250	XS C	'78	ISON144	4,73
250	XS C	'81	ISON144	4,73
250	XS S	'79→'82	ISON144	4,73
250	XT	'80→'83	ISON145	4,77
250	XT X	'06→'08	ISON141	5,56
250	XV S Virago	'95→'15	ISON145	4,77
250	XV Virago	'89→'94	ISON145	4,77
250	XVS Dragster	'01→'03	ISON145	4,77
250	YBR	'07→'12	ISON141	5,56
250	YFB FW Timberwolf	'94→'00	ISON143	7,76
250	YFB Timberwolf	'92→'98	ISON143	7,76
250	YFM	'90→'91	ISON143	7,76
250	YFM B Big Bear	'07→'10	ISON143	7,76
250	YFM B Bruin	'05→'06	ISON143	7,76
250	YFM R Raptor	'08→'13	ISON141	5,56
250	YFM X Bear Tracker	'99→'04	ISON143	7,76
250	YZ F	'01→'02	ISON142	8,72
250	YZ F	'03→'21	ISON141	5,56
300	X-Max ABS	'17→'20	ISON141	5,56
300	X-Max ABS Iron Max	'19	ISON141	5,56
300	X-Max Tech Max	'20	ISON141	5,56
320	MT-03 ABS	'16→'20	ISON204	8,06
320	YZF-R3 ABS	'15→'20	ISON204	8,06
350	TT	'85→'89	ISON143	7,76
350	TT A	'90→'97	ISON143	7,76
350	XT	'85→'98	ISON143	7,76
350	YFM A Grizzly	'16→'18	ISON204	8,06
350	YFM AN Bruin	'04→'06	ISON303	8,06
350	YFM ER	'92→'95	ISON142	8,72
350	YFM FA Bruin	'04→'06	ISON303	8,06
350	YFM FG/FWA Grizzly	'07→'18	ISON204	8,06
350	YFM FW Big Bear	'87→'98	ISON142	8,72



FILTRI ISON / ISON FILTER

CC	Modello Model	Anno Years	Codice Code	€	CC	Modello Model	Anno Years	Codice Code	€
350	YFM FWX Big Bear	'99	ISON142	8,72	500	FZR	'91→'93	ISON303	8,06
350	YFM FX Wolverine	'95→'05	ISON142	8,72	500	SR	'78→'00	ISON145	4,77
350	YFM G Grizzly	'07→'10	ISON204	8,06	500	SR	'80	ISON154	6,42
350	YFM GGI Grizzly	'07→'10	ISON204	8,06	500	SR S	'98	ISON145	4,77
350	YFM R Raptor	'05→'13	ISON142	8,72	500	T-Max	'01→'12	ISON147	8,34
350	YFM Raptor	'04	ISON142	8,72	500	T-Max ABS	'08→'12	ISON147	8,34
350	YFM U	'96→'98	ISON142	8,72	500	XS	'75	ISON147	8,34
350	YFM X Warrior	'87→'04	ISON142	8,72	500	XS	'76→'79	ISON145	4,77
350	YFM X Wolverine	'06→'09	ISON204	8,06	500	XT	'76→'89	ISON145	4,77
400	FZ	'85	ISON144	4,73	500	XT E	'90→'96	ISON145	4,77
400	FZ	'96	ISON144	4,73	500	XT T	'88→'89	ISON145	4,77
400	FZR	'88	ISON144	4,73	500	XT Z	'88→'89	ISON145	4,77
400	FZR Genesis	'86	ISON144	4,73	530	T-Max	'12→'16	ISON147	8,34
400	FZR R	'89	ISON144	4,73	530	T-Max ABS	'12→'16	ISON147	8,34
400	FZR RR	'90→'95	ISON303	8,06	530	T-Max ABS	'17→'19	ISON204	8,06
400	Majesty	'04→'12	ISON972	2,78	530	T-Max ABS DX	'17→'19	ISON204	8,06
400	Majesty ABS	'05→'13	ISON972	2,78	530	T-Max ABS SX	'17→'19	ISON204	8,06
400	SR	'78→'83	ISON145	4,77	530	T-Max ABS SX Sport Edition	'18→'19	ISON204	8,06
400	SR	'88→'89	ISON145	4,77	530	T-Max Black Max	'12→'14	ISON147	8,34
400	SR	'14→'16	ISON145	4,77	530	T-Max Black Max ABS	'12→'14	ISON147	8,34
400	SRX	'85→'85	ISON145	4,77	530	T-Max Bronze Max	'12→'14	ISON147	8,34
400	SRX	'90→'96	ISON145	4,77	530	T-Max Iron Max	'14→'16	ISON147	8,34
400	WR F	'98→'99	ISON142	8,72	530	T-Max Iron Max ABS	'14→'16	ISON147	8,34
400	XJ	'82	ISON144	4,73	530	T-Max Lux Max ABS	'16	ISON147	8,34
400	XJR	'93→'99	ISON303	8,06	535	XV S Virago	'95→'03	ISON145	4,77
400	X-Max	'13→'16	ISON972	2,78	535	XV Virago	'88→'03	ISON145	4,77
400	X-Max ABS	'14→'20	ISON972	2,78	550	XJ	'81→'84	ISON144	4,73
400	X-Max Iron Max	'16→'16	ISON972	2,78	550	XJ Maxim	'81→'83	ISON144	4,73
400	XS	'79	ISON144	4,73	550	XJ R Seca	'81→'83	ISON144	4,73
400	XS C	'78→'80	ISON144	4,73	550	XT	'82→'83	ISON145	4,77
400	XS DOHC	'82→'86	ISON144	4,73	550	XZ	'82→'84	ISON145	4,77
400	XS SE	'80→'81	ISON144	4,73	550	YFM D Grizzly	'13	ISON204	8,06
400	XT	'81	ISON145	4,77	550	YFM FG Grizzly	'09→'13	ISON204	8,06
400	XT 4 Valve	'82→'84	ISON145	4,77	550	YFM FWA Grizzly	'09→'16	ISON204	8,06
400	YFM A Kodiak	'03	ISON145	8,06	560	T-Max ABS	'20	ISON204	8,06
400	YFM FA Kodiak	'00→'06	ISON303	8,06	560	T-Max Tech Max ABS	'20	ISON204	8,06
400	YFM FG Grizzly	'07→'08	ISON204	8,06	600	FZ	'86→'88	ISON144	4,73
400	YFM FP Big Bear	'03→'04	ISON142	8,72	600	FZ 6 N	'04→'06	ISON303	8,06
400	YFM FW Big Bear	'02	ISON142	8,72	600	FZ 6 N	'07→'07	ISON204	8,06
400	YFM FW Kodiak	'93→'99	ISON303	8,06	600	FZ 6 S Fazer	'04→'06	ISON303	8,06
400	YZ F	'98→'99	ISON142	8,72	600	FZ 6 S Fazer	'07→'07	ISON204	8,06
426	WR F	'00→'02	ISON142	8,72	600	FZ 6 S Fazer ABS	'06	ISON303	8,06
426	YZ F	'00→'02	ISON142	8,72	600	FZ 6 S Fazer ABS	'07	ISON204	8,06
450	WR F	'03→'20	ISON141	5,56	600	FZ 6 S2	'07→'10	ISON204	8,06
450	YFM D Grizzly	'14→'15	ISON204	8,06	600	FZ 6 S2 Fazer	'07→'09	ISON204	8,06
450	YFM FA Kodiak	'03→'06	ISON303	8,06	600	FZ 6 S2 Fazer ABS	'08→'09	ISON204	8,06
450	YFM FG Grizzly	'07→'13	ISON204	8,06	600	FZR	'89→'90	ISON144	4,73
450	YFM FGI Grizzly	'10→'12	ISON204	8,06	600	FZR	'91→'93	ISON303	8,06
450	YFM FGP Grizzly	'11→'13	ISON204	8,06	600	FZR R	'94→'95	ISON303	8,06
450	YFM FWA D Grizzly	'16→'17	ISON204	8,06	600	FZS Fazer	'98→'03	ISON147	8,34
450	YFM FWA Grizzly	'12→'17	ISON204	8,06	600	SRX	'85→'93	ISON145	4,77
450	YFM FWB D Kodiak	'18→'20	ISON204	8,06	600	TT E	'94→'01	ISON145	4,77
450	YFM FWB Kodiak	'18→'20	ISON204	8,06	600	TT K	'93→'96	ISON145	4,77
450	YFM FX Wolverine	'06→'06	ISON303	8,06	600	TT L	'84→'84	ISON145	4,77
450	YFM FX Wolverine	'07→'10	ISON204	8,06	600	TT N	'85→'88	ISON145	4,77
450	YFM P Grizzly	'14	ISON204	8,06	600	TT R	'97→'02	ISON145	4,77
450	YFZ	'03→'13	ISON141	5,56	600	TT RE	'02→'04	ISON145	4,77
450	YFZ R	'09→'18	ISON141	5,56	600	TT W	'89→'92	ISON145	4,77
450	YFZ R	'19→'20	ISON141	5,56	600	XJ 6 F Diversion	'10→'16	ISON204	8,06
450	YXR F	'06→'06	ISON204	8,06	600	XJ 6 F Diversion ABS	'10→'16	ISON204	8,06
450	YZ F	'03→'21	ISON141	5,56	600	XJ 6 N Diversion	'09→'16	ISON204	8,06
450	YZ FX	'16→'20	ISON141	5,56	600	XJ 6 N Diversion ABS	'09→'16	ISON204	8,06
500	FZR	'89→'90	ISON144	4,73	600	XJ 6 S Diversion	'09→'16	ISON204	8,06



FILTRI ISON / ISON FILTER

CC	Modello Model	Anno Years	Codice Code	€	CC	Modello Model	Anno Years	Codice Code	€
600	XJ 6 S Diversion ABS	'09→'16	ISON204	8,06	750	XV Virago	'92→'97	ISON145	4,77
600	XJ 6 SP Diversion ABS	'13	ISON204	8,06	750	YZF R	'93→'98	ISON303	8,06
600	XJ N Diversion	'91→'03	ISON303	8,06	750	YZF SP	'93→'99	ISON303	8,06
600	XJ Radian	'84→'91	ISON144	4,73	50	YZF-R7 OW02	'99→'03	ISON303	8,06
600	XJ S Diversion	'92→'03	ISON303	8,06	800	FZ 8 N	'10→'16	ISON204	8,06
600	XT	'84→'95	ISON145	4,77	800	FZ 8 N ABS	'10→'16	ISON204	8,06
600	XT E	'90→'03	ISON145	4,77	800	FZ 8 S Fazer	'10→'16	ISON204	8,06
600	XT Z Tenere	'83→'95	ISON145	4,77	800	FZ 8 S Fazer ABS	'10→'16	ISON204	8,06
600	YFM F Grizzly	'00→'01	ISON145	4,77	850	NIKEN ABS (MXT)	'18→'20	ISON204	8,06
600	YFM FH Grizzly Hunting	'00	ISON145	4,77	850	NIKEN GT ABS (MXT)	'19→'20	ISON204	8,06
600	YFM FWA Grizzly	'98→'99	ISON145	4,77	850	TDM	'91→'01	ISON145	4,77
600	YX Radian	'86→'90	ISON144	4,73	850	TRX	'96→'99	ISON145	4,77
600	YZF R Thundercat	'96→'03	ISON303	8,06	850	XS	'80	ISON146	7,51
600	YZF-R6	'99→'05	ISON303	8,06	900	MT-09	'13→'16	ISON204	8,06
600	YZF-R6	'06→'20	ISON204	8,06	900	MT-09 ABS	'14→'20	ISON204	8,06
650	XJ	'80→'84	ISON144	4,73	900	MT-09 SP ABS	'18→'20	ISON204	8,06
650	XJ L	'81→'82	ISON144	4,73	900	MT-09 Sport Tracker ABS	'14→'17	ISON204	8,06
650	XVS A Drag Star Classic	'98→'07	ISON145	4,77	900	MT-09 Street Rally ABS	'14→'17	ISON204	8,06
650	XVS Drag Star	'97→'04	ISON145	4,77	900	MT-09 Tracer ABS	'15→'20	ISON204	8,06
660	MT-03	'06→'14	ISON145	4,77	900	MT-09 Tracer GT ABS	'18→'20	ISON204	8,06
660	SZR	'96→'98	ISON145	4,77	900	TDM	'02→'14	ISON145	4,77
660	XT R	'04→'16	ISON145	4,77	900	TDM ABS	'05→'13	ISON145	4,77
660	XT X Supermoto	'04→'16	ISON145	4,77	900	XJ	'83→'94	ISON144	4,73
660	XT Z Tenere	'08→'16	ISON145	4,77	900	XJ F	'83→'94	ISON144	4,73
660	XT Z Tenere ABS	'11→'16	ISON145	4,77	900	XJ S Diversion	'95→'03	ISON303	8,06
660	XTZ Tenere	'90→'00	ISON145	4,77	900	XSR	'16→'20	ISON204	8,06
660	YFM F Grizzly	'02→'04	ISON303	8,06	900	XSR 60th Anniversary	'16→'16	ISON204	8,06
660	YFM FA Grizzly	'05→'06	ISON303	8,06	900	XSR Abarth ABS	'16→'19	ISON204	8,06
660	YFM FG Grizzly	'07→'08	ISON204	8,06	900	XSR Speedblock	'16→'17	ISON204	8,06
660	YFM FWA Grizzly	'02→'06	ISON303	8,06	950	SCR	'17→'20	ISON204	8,06
660	YFM FWA Grizzly	'07→'08	ISON204	8,06	950	XV	'17	ISON204	8,06
660	YFM R Raptor	'01→'05	ISON147	8,34	950	XV R	'14→'20	ISON204	8,06
660	YFM R Raptor	'06	ISON303	8,06	950	XV Racer	'17→'18	ISON204	8,06
660	YXR FA Rhino	'04→'06	ISON303	8,06	950	XVS A Midnight Star	'09→'13	ISON204	8,06
700	MT-07	'14→'16	ISON204	8,06	950	XVS CR Bolt C-Spec	'15→'16	ISON204	8,06
700	MT-07 ABS	'14→'20	ISON204	8,06	950	XVS CU	'14→'16	ISON204	8,06
700	MT-07 Moto Cage ABS	'15→'17	ISON204	8,06	1000	FZ 1 N	'06→'15	ISON204	8,06
700	MT-07 Tracer ABS	'16→'20	ISON204	8,06	1000	FZ 1 N Fazer ABS	'08→'15	ISON204	8,06
700	MT-07 Tracer GT	'19→'20	ISON204	8,06	1000	FZ 1 S Fazer	'06→'15	ISON204	8,06
700	XSR	'16→'20	ISON204	8,06	1000	FZ 1 S Fazer ABS	'08→'15	ISON204	8,06
700	XSR X Tribute	'19→'20	ISON204	8,06	1000	FZR EXUP	'89→'90	ISON401	5,81
700	XT Z Tenere	'19→'20	ISON204	8,06	1000	FZR EXUP	'91→'97	ISON303	8,06
700	YFM D Grizzly	'14→'14	ISON204	8,06	1000	FZR Genesis	'87→'88	ISON401	5,81
700	YFM FGP Grizzly	'07→'13	ISON204	8,06	1000	FZS Fazer	'01→'06	ISON303	8,06
700	YFM FWAD Grizzly	'17→'20	ISON204	8,06	1000	GTS	'93→'99	ISON303	8,06
700	YFM FWBD Kodiak	'19→'20	ISON204	8,06	1000	MT-10	'16→'20	ISON204	8,06
700	YFM P Grizzly	'14→'14	ISON204	8,06	1000	MT-10 SP	'17→'20	ISON204	8,06
700	YFM R Raptor	'05→'20	ISON145	4,77	1000	MT-10 Tourer Edition	'17→'20	ISON204	8,06
700	YXM	'14→'14	ISON204	8,06	1000	XV SE Virago	'88	ISON145	4,77
700	YXR F Rhino	'11→'13	ISON204	8,06	1000	XV TR1	'81	ISON145	4,77
700	YXR FI Rhino	'08	ISON204	8,06	1000	XV Virago	'86	ISON145	4,77
700	YXR FI Rhino	'09	ISON204	8,06	1000	YZF R Thunderace	'96→'01	ISON303	8,06
750	FZ	'85→'91	ISON401	5,81	1000	YZF-R1	'98→'06	ISON303	8,06
750	FZR Genesis	'87→'89	ISON401	5,81	1000	YZF-R1	'07→'19	ISON204	8,06
750	FZR R OW01	'88	ISON401	5,81	1000	YZF-R1 60th Anniversary	'15→'16	ISON204	8,06
750	FZR R OW01	'89→'90	ISON303	8,06	1000	YZF-R1 SP	'06→'06	ISON303	8,06
750	FZX Fazer	'86→'97	ISON401	5,81	1000	YZF-R1M	'15→'20	ISON204	8,06
750	XJ	'82→'84	ISON144	4,73	1000	YZF-R1M 60th Anniversary	'15→'16	ISON204	8,06
750	XJ R Seca	'81→'83	ISON144	4,73	1100	BT Bulldog	'02→'06	ISON145	4,77
750	XS	'77→'79	ISON146	7,51	1100	FJ	'83→'85	ISON401	5,81
750	XS SE	'79→'80	ISON146	7,51	1100	XS	'78→'80	ISON146	7,51
750	XTZ Super Tenere	'89→'00	ISON145	4,77	1100	XS S	'81	ISON146	7,51
750	XV SE	'81	ISON145	4,77	1100	XV Virago	'89→'99	ISON145	4,77



FILTRI ISON / ISON FILTER

CC	Modello Model	Anno Years	Codice Code	€	CC	Modello Model	Anno Years	Codice Code	€
1100	XVS A Drag Star Classic	'00→'06	ISON145	4,77					
1100	XVS Drag Star	'99→'04	ISON145	4,77					
1200	FJ	'86→'95	ISON401	5,81					
1200	FJ ABS	'91→'95	ISON401	5,81					
1200	V-MAX	'91→'95	ISON146	7,51					
1200	V-MAX	'96→'03	ISON303	8,06					
1200	XJR	'95→'98	ISON401	5,81					
1200	XT Z Super Tenere ABS	'10→'20	ISON204	8,06					
1200	XT ZE Super Tenere ABS Raid Edition	'18→'20	ISON204	8,06					
1200	XVZ 12 T	'85→'85	ISON146	7,51					
1300	FJR	'01→'05	ISON148	11,93					
1300	FJR ABS	'03→'12	ISON148	11,93					
1300	FJR ABS	'13→'20	ISON204	8,06					
1300	FJR AE ABS	'15→'20	ISON204	8,06					
1300	FJR AS ABS	'06→'11	ISON148	11,93					
1300	FJR AS ABS	'13→'20	ISON204	8,06					
1300	XJR	'98→'14	ISON401	5,81					
1300	XJR C	'15→'17	ISON401	5,81					
1300	XJR C Racer	'16→'17	ISON401	5,81					
1300	XJR SP	'99→'01	ISON401	5,81					
1300	XVS A Midnight Star	'07→'09	ISON147	8,34					
1300	XVS A midnight staR	'10→'16	ISON204	8,06					
1300	XVS CU Midnight Star	'14→'16	ISON204	8,06					
1300	XVZ Royal Star	'96→'01	ISON303	8,06					
1300	XVZ TF Venture Star	'99→'01	ISON303	8,06					
1600	XV A Wildstar	'99→'04	ISON303	8,06					
1670	MT-01	'05→'12	ISON303	8,06					
1670	MT-01 SP	'09→'09	ISON303	8,06					
1700	V-Max	'09→'16	ISON303	8,06					
1700	XV PC Road Star Warrior	'03→'05	ISON303	8,06					
1900	XV A Midnight Star	'06→'10	ISON303	8,06					
1900	XV A Midnight Star	'11→'16	ISON204	8,06					
1900	XV ACFD Midnight Star	'14→'16	ISON204	8,06					