

Racing Pads Z03/Z04 compound



Brembo Racing present its range of high performing racing brake pads. These racing pads are exclusively developed for the highest levels of racing use and have been designed to give top performances in extreme situations. The main features are a high braking control, a more stable system, an increase in braking power, resistance to higher temperature and low wear. The pads are easy to bed.

Brembo Racing Z04 compound is used in the world Superbike & Supersport Championships and are now available for Supertock, Motocross and Supermotard applications.

Brembo Racing presenta la nuova gamma di pastiglie racing ad alte prestazioni. Queste pastiglie sono state sviluppate esclusivamente per le competizioni di alto livello e sono state progettate per offrire il massimo delle prestazioni nelle competizioni più estreme: maggiore controllo della frenata, stabilità dell'impianto, aumento della potenza frenante, resistenza alle alte temperature ed usura ridotta. Sono inoltre facili da rodare.

La miscela Brembo Racing Z04, utilizzata nei Campionati Mondiali Superbike e Supersport, è ora disponibile per applicazioni Superstock, Motocross e Supermotard.



(see application list page 13)

(vedere lista applicazioni a pag. 13)

Code M478Z04
Code M478Z03

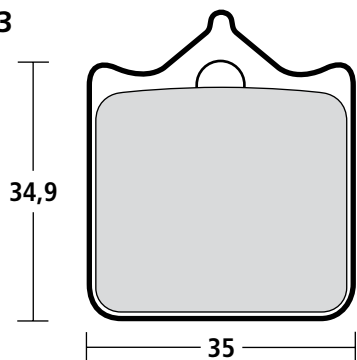

Code M488Z04
Code M488Z03

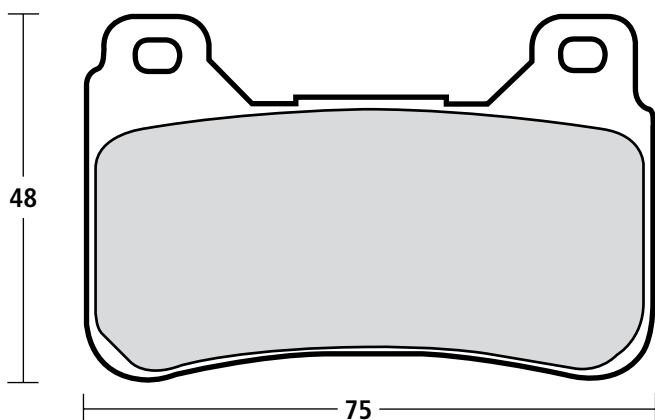

Code M497Z04
Code M497Z03

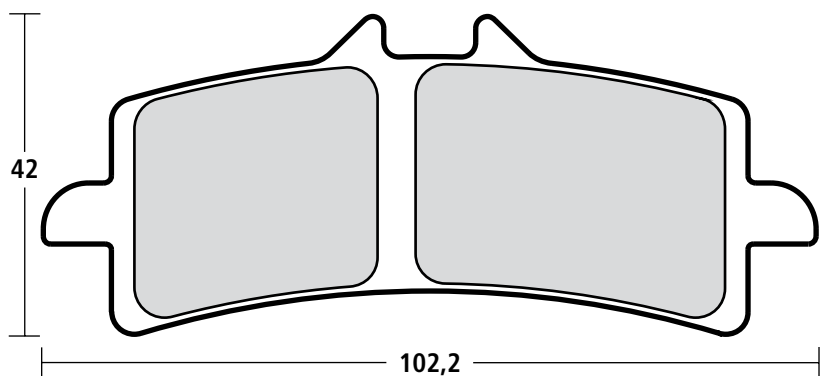

Code M538Z04
Code M538Z03

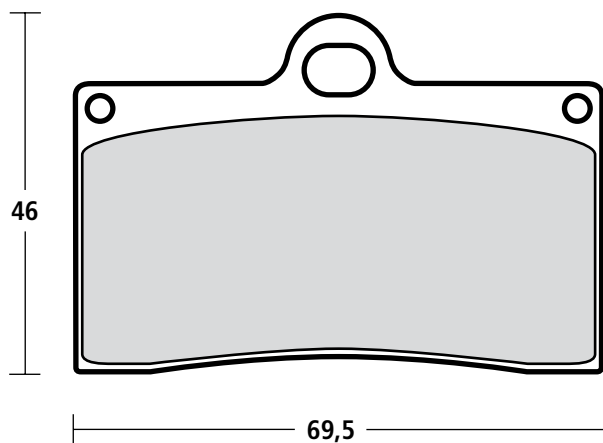

(see application list page 13)

(vedere lista applicazioni a pag. 13)

Code M508Z04

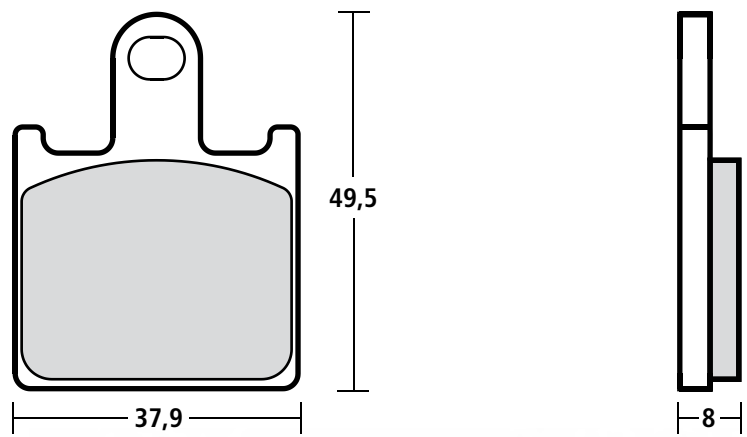

Code M518Z04

Code M518Z03

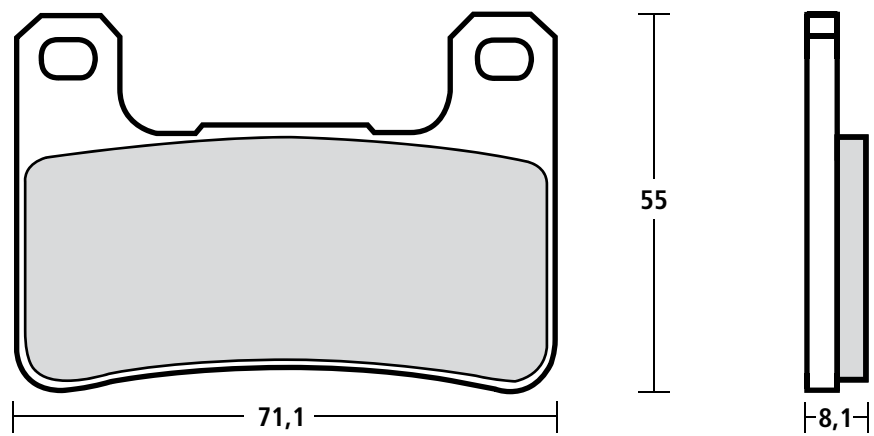

Code M528Z04

Code M528Z03

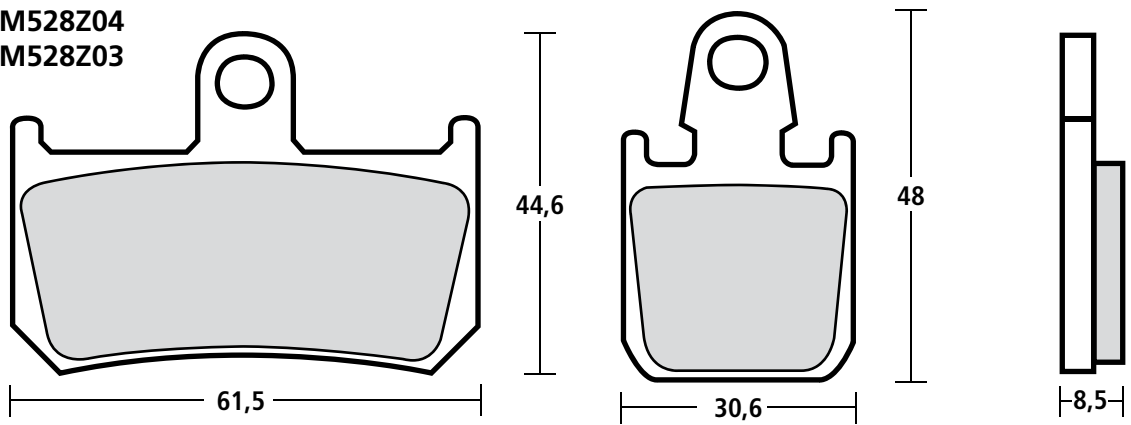

Code M5510Z04

Code M5510Z03

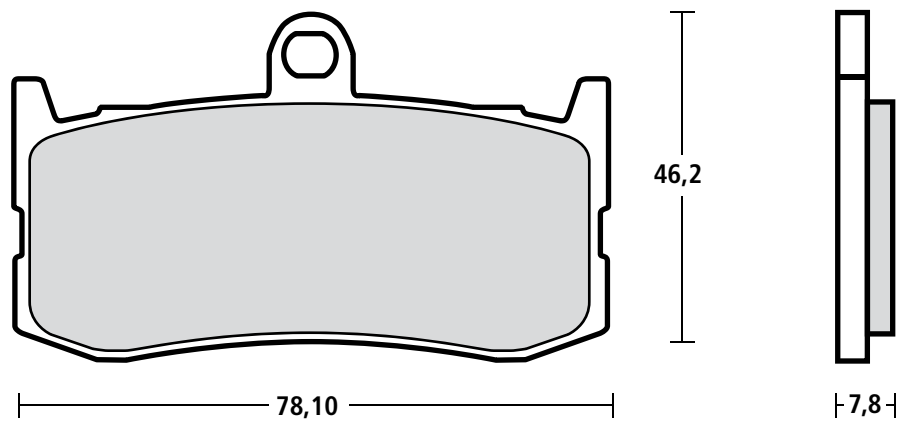

Code 107670823

Code M548Z03

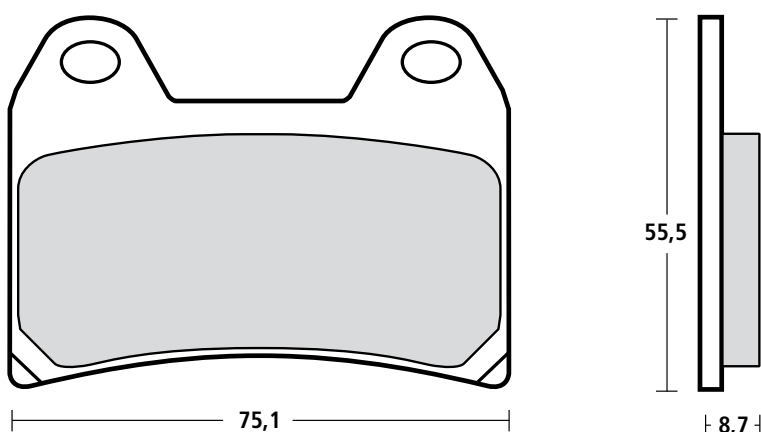

Model	CC	Year From	Year To	N° Discs	Code	Model	CC	Year From	Year To	N° Discs	Code
APRILIA											
RSV	1.000	'02	>	••	M478Z04 M478Z03	STREETFIGHTER	848	'12	>	••	107670823 M548Z03
RSV	1.000	'97	'01	••	107670823 M548Z03	STREETFIGHTER S	848	'12	>	••	107670823 M548Z03
RSV FACTORY	1.000	'04	>	••	M478Z04 M478Z03	916	916	'94	'96	••	M538Z04 M538Z03
RSV NERA	1.000	'04	>	••	M478Z04 M478Z03	916 BIPOSTO, SENNA	916	'94	'98	••	M538Z04 M538Z03
RSV R	1.000	'01	'03	••	M478Z04 M478Z03	916 S, 916 SP	916	'94	'96	••	M538Z04 M538Z03
RSV R	1.000	'00	'00	••	107670823 M548Z03	916 SPS	916	'97	>	••	M538Z04 M538Z03
RSV SP	1.000	'99	>	••	107670823 M548Z03	916 SPS	916	'98	>	••	107670823 M548Z03
RSV TUONO 4R	1.000	'11	>	••	107670823 M548Z03	MONSTER S4, S4 FOGGY	916	'02	'03	••	107670823 M548Z03
RSV4 FACTORY	1.000	'09	>	••	M497Z04 M497Z03	Desmosedici RR (D16RR)	990	'07	>	••	M497Z04 M497Z03
RSV4 R	1.000	'10	>	••	M497Z04 M497Z03	996 R	996	'01	>	••	M478Z04 M478Z03
RSV4 R APRC ABS	1.000	'14	>	••	M497Z04 M497Z03	996, 996 S	996	'01	>	••	107670823 M548Z03
TUONO V4 ABS	1.000	'13	>	••	107670823 M548Z03	996, 996 S, 996 SPS,	996	'00	>	••	107670823 M548Z03
TUONO FIGHTER	1.000	'03	>	••	107670823 M548Z03	996 SPS III					
TUONO R	1.000	'03	>	••	M478Z04 M478Z03	996, 996 SPS, 996 SPS II	996	'99	>	••	107670823 M548Z03
TUONO RACING	1.000	'04	>	••	M478Z04 M478Z03	MONSTER S4 R	996	'04	>	••	107670823 M548Z03
DORSODURO / ABS	1.200	'11	>	••	107670823 M548Z03	MONSTER S4 R	996	'03	'03	••	107670823 M548Z03
BIMOTA											
BB3	1.000	'13	>	••	M497Z04 M497Z03	999	998	'03	'07	••	M478Z04 M478Z03
BMW											
S 1000 R ABS	1.000	'14	>	••	M478Z04 M478Z03	998 F.E.	998	'04	>	••	M478Z04 M478Z03
S 1000 RR	1.000	'09	>	••	M478Z04 M478Z03	998 R	998	'02	>	••	M478Z04 M478Z03
HP4	1.000	'13	>	••	M497Z04 M497Z03	998 S	998	'02	>	••	M478Z04 M478Z03
DUCATI											
749	748	'03	'07	••	M478Z04 M478Z03	999 R	998	'03	'07	••	M478Z04 M478Z03
748 R	748	'01	'02	••	M478Z04 M478Z03	999 S	998	'03	'07	••	M478Z04 M478Z03
749 DARK	748	'05	'06	••	M478Z04 M478Z03	999 XEROX	998	'06	>	••	M478Z04 M478Z03
749 R	748	'03	'07	••	M478Z04 M478Z03	MONSTER S4 R	998	'07	>	••	M478Z04 M478Z03
749 S	748	'03	'07	••	M478Z04 M478Z03	Testastretta					
748 BIPOSTO	748	'95	'97	••	M538Z04 M538Z03	MONSTER S4 RS	998	'06	>	••	M478Z04 M478Z03
748 BIPOSTO	748	'98	'98	••	M538Z04 M538Z03	Testastretta					
748 SP	748	'95	'97	••	M538Z04 M538Z03	998	998	'02	>	••	107670823 M548Z03
748	748	'00	'02	••	107670823 M548Z03	998 Matrix	998	'04	>	••	107670823 M548Z03
748 BIPOSTO	748	'99	>	••	107670823 M548Z03	MONSTER 1000	1.000	'04	'05	••	107670823 M548Z03
748 R	748	'00	>	••	107670823 M548Z03	MONSTER 1000 S	1.000	'05	>	••	107670823 M548Z03
748 S	748	'00	'02	••	107670823 M548Z03	MONSTER 1000 S i.e.	1.000	'03	>	••	107670823 M548Z03
748 SPS	748	'98	'99	••	107670823 M548Z03	MONSTER S2 R 1000	1.000	'06	>	••	107670823 M548Z03
EVO	848	'11	>	••	M497Z04 M497Z03	1098 R BAYLISS	1.098	'09	>	••	M497Z04 M497Z03
848	848	'08	>	••	107670823 M548Z03	STREETFIGHTER	1.098	'09	>	••	M497Z04 M497Z03
						STREETFIGHTER S	1.098	'09	>	••	M497Z04 M497Z03
						1098	1.099	'07	>	••	M497Z04 M497Z03
						1098 S	1.099	'07	>	••	M497Z04 M497Z03



Model	CC	Year From To	N° Discs	Code
1098 S Tricolore	1.099	'07 >	••	M497Z04 M497Z03
HYPERMOTARD EVO SP	1.100	'10 >	••	M497Z04 M497Z03
HYPERMOTARD S	1.100	'07 >	••	M497Z04 M497Z03
HYPERMOTARD	1.100	'07 >	••	107670823 M548Z03
HYPERMOTARD EVO	1.100	'10 >	••	107670823 M548Z03
MONSTER 1100	1.100	'09 >	••	107670823 M548Z03
MONSTER 1100 EVO ABS	1.100	'11 >	••	107670823 M548Z03
MONSTER 1100 S	1.100	'09 >	••	107670823 M548Z03
1198	1.198	'09 >	••	M497Z04 M497Z03
1098 R	1.198	'08 >	••	M497Z04 M497Z03
1198 S	1.198	'09 >	••	M497Z04 M497Z03
1198 SP	1.198	'11 >	••	M497Z04 M497Z03
1199 PANIGALE	1.199	'12 >	••	M497Z04 M497Z03
1199 PANIGALE R	1.199	'13 >	••	M497Z04 M497Z03
1199 PANIGALE S	1.199	'12 >	••	M497Z04 M497Z03
1199 SUPERLEGGERA	1.199	'14 >	••	M497Z04 M497Z03
MONSTER S	1.200	'14 >	••	M497Z04 M497Z03
MULTISTRADA	1.200	'10 >	••	107670823 M548Z03
MULTISTRADA S GT	1.200	'13 >	••	107670823 M548Z03
MULTISTRADA S	1.200	'11 >	••	107670823 M548Z03
Pikes Peak				
HONDA				
CBR RR	600	'05 '06	••	M488Z04 M488Z03
CBR RR	600	'07 >	••	M488Z04 M488Z03
CBR600RR	600	'09 >	••	M488Z04 M488Z03
CB R	1.000	'08 >	••	M488Z04 M488Z03
CBR RR	1.000	'04 '05	••	M488Z04 M488Z03
CBR RR	1.000	'06 >	••	M488Z04 M488Z03
CBR RR FIREBLADE	1.000	'09 '13	••	M488Z04 M488Z03
CBR RR FIREBLADE ABS	1.000	'09 >	••	M488Z04 M488Z03
CBR RR SP	1.000	'14 >	••	M497Z04 M497Z03
HUSQVARNA				
SMR	449	'11 >	•	M478Z04 M478Z03
SMR	450	'05 >	•	M478Z04 M478Z03
SMR	450	'06 >	•	M478Z04 M478Z03
SMR R	450	'06 >	•	M478Z04 M478Z03
SMR	450	'03 '04	•	M538Z04 M538Z03
SMR	510	'05 '05	•	M478Z04 M478Z03
SMR	510	'06 >	•	M478Z04 M478Z03
SMR	511	'11 >	•	M478Z04 M478Z03
SMR	570	'01 '02	•	M538Z04 M538Z03
SMR	570	'03 '04	•	M538Z04 M538Z03
SMR R	570	'04 >	•	M538Z04 M538Z03
SM	610	'05 >	•	M478Z04 M478Z03
SMS	610	'06 >	•	M478Z04 M478Z03
SM	610	'98 '99	•	107670823 M548Z03
SMS	610	'00 '01	•	107670823 M548Z03
SMS	610	'03 '04	•	107670823 M548Z03
SMS	630	'10 >	•	M478Z04 M478Z03
SMR	630	'04 >	•	107670823 M548Z03
NUDA R	900	'12 >	••	M497Z04 M497Z03
NUDA	900	'12 >	••	107670823 M548Z03
KAWASAKI				
ZX-6R	600	'07 >	••	M508Z04 -
Z 750 R	750	'11 >	••	M508Z04 -
Z 1000	1.000	'07 '09	••	M508Z04 -

Model	CC	Year From To	N° Discs	Code
Z 1000	1.000	'10 >	••	M518Z04 M518Z03
Z 1000 SX	1.000	'11 >	••	M518Z04 M518Z03
ZX R	1.000	'11 >	••	M518Z04 M518Z03
ZX 10 R	1.000	'08 '10	••	M518Z04 M518Z03
ZX 10 R	1.000	'11 >	••	M518Z04 M518Z03
KTM				
SM FACTORY REPLICA	450	'04 >	•	M538Z04 M538Z03
SMR	525	'04 '04	•	M538Z04 M538Z03
SMC	625	'05 >	•	107670823 M548Z03
LC4 SUPERMOTO	640	'03 '04	•	M538Z04 M538Z03
LC4 SUPERMOTO	640	'05 >	•	107670823 M548Z03
SM FACTORY	660	'02 >	•	M538Z04 M538Z03
SM FACTORY REPLICA	660	'03 >	•	M538Z04 M538Z03
SMC	660	'03 '03	•	M538Z04 M538Z03
SMS	660	'07 >	•	M538Z04 M538Z03
SMC	660	'04 '05	•	107670823 M548Z03
SMC	660	'06 >	•	107670823 M548Z03
DUKE	690	'08 '11	•	M478Z04 M478Z03
DUKE R	690	'10 '11	•	M478Z04 M478Z03
SMC	690	'08 >	•	M478Z04 M478Z03
SMC R	690	'14 >	•	M478Z04 M478Z03
SUPERMOTO PRESTIGE	690	'07 >	•	M478Z04 M478Z03
DUKE R	690	'14 >	•	M497Z04 M497Z03
SUPERMOTO	690	'07 >	•	107670823 M548Z03
DUKE	950	'03 >	••	M478Z04 M478Z03
SUPERMOTO	950	'05 >	••	M478Z04 M478Z03
SUPERMOTO R	950	'07 >	••	M478Z04 M478Z03
LC8 990 SUPER DUKE R	990	'09 >	••	M478Z04 M478Z03
LC8 990 SUPERMOTO	990	'09 >	••	M478Z04 M478Z03
LC8 990 SUPERMOTO T	990	'09 >	••	M478Z04 M478Z03
SUPER DUKE	990	'05 '05	••	M478Z04 M478Z03
SUPER DUKE	990	'06 >	••	M478Z04 M478Z03
SUPER DUKE R	990	'07 >	••	M478Z04 M478Z03
SUPERMOTO	990	'06 >	••	M478Z04 M478Z03
LC8 990 SUPERMOTO R	990	'09 >	••	M497Z04 M497Z03
RC8	1.190	'08 >	••	M497Z04 M497Z03
RC8 1190	1.190	'09 >	••	M497Z04 M497Z03
RC8 1190 R	1.190	'09 >	••	M497Z04 M497Z03
R TRACK	1.190	'11 >	••	M497Z04 M497Z03
SUPER DUKE R	1.290	'14 >	••	M497Z04 M497Z03
MV AGUSTA				
BRUTALE	675	'12 >	••	107670823 M548Z03
F3	675	'11 >	••	107670823 M548Z03
F3	800	'13 >	••	M497Z04 M497Z03
BRUTALE R	910	'06 >	••	M478Z04 M478Z03
BRUTALE	920	'12 >	••	107670823 M548Z03
BRUTALE R	989	'08 >	••	107670823 M548Z03
BRUTALE R	990	'10 >	••	107670823 M548Z03
F4 R 312	1.000	'07 >	••	M478Z04 M478Z03
F4 R, R 1+1	1.000	'06 >	••	M478Z04 M478Z03
F4 SENNA	1.000	'06 >	••	M478Z04 M478Z03
F4 R CORSA CORTA	1.000	'12 >	••	M497Z04 M497Z03
F4 RR	1.000	'11 >	••	M497Z04 M497Z03
F4 RR CORSA CORTA	1.000	'12 >	••	M497Z04 M497Z03
BRUTALE 1078 RR	1.078	'09 >	••	M497Z04 M497Z03
BRUTALE RR	1.078	'08 >	••	M497Z04 M497Z03
F4 CC	1.078	'08 >	••	M497Z04 M497Z03
F4 RR 312	1.078	'08 >	••	M497Z04 M497Z03

Model	CC	Year From To	N° Discs	Code
BRUTALE CORSA	1.090	'14 >	••	M497Z04 M497Z03
BRUTALE RR	1.090	'10 '11	••	M497Z04 M497Z03
BRUTALE RR	1.090	'12 >	••	M497Z04 M497Z03
BRUTALE R	1.090	'12 >	••	107670823 M548Z03

SUZUKI

GSX-R	600	'04 '10	••	M518Z04 M518Z03
GSX-R	600	'11 >	••	M497Z04 M497Z03
GSX-R	750	'04 '10	••	M518Z04 M518Z03
GSX-R	750	'11 >	••	M497Z04 M497Z03
GSX R	1.000	'04 '11	••	M518Z04 M518Z03
GSX R	1.000	'12 >	••	M497Z04 M497Z03
GSX-R Hayabusa	1.300	'08 '12	••	M518Z04 M518Z03
GSX R HAYABUSA (Red Call)	1.300	'13 >	••	M497Z04 M497Z03

TM

SMR F	400	'02 '02	•	M538Z04 M538Z03
SMR F	400	'03 >	•	M538Z04 M538Z03
SMR F	450	'04 >	•	M538Z04 M538Z03
SMX F	450	'03 >	•	M538Z04 M538Z03
SMR F	530	'03 >	•	M538Z04 M538Z03
SMR F ES	530	'03 >	•	M538Z04 M538Z03

Thermopaints and thermotapes are used to keep the braking system temperatures under control on the track: paints measure the temperature of the disk, while thermotapes indicate the caliper temperature. Put the paints on the outer edge, applying the colour band with 1cm. of distance among them, eventually add a few drops of diluent in case the pigment is not fluid enough. Thermotapes are to be applied on the caliper on the pistons area.

Model	CC	Year From To	N° Discs	Code
SMX F	600	'03 >	•	M538Z04 M538Z03
SMX F	660	'05 >	•	M478Z04 M478Z03

TRIUMPH

DAYTONA R	675	'13 >	••	M497Z04 M497Z03
DAYTONA R TRIPLE	675	'11 '12	••	M497Z04 M497Z03
DAYTONA R TRIPLE	675	'13 >	••	M497Z04 M497Z03
DAYTONA TRIPLE	675	'09 >	••	M5510Z04 M5510Z03
SPEED TRIPLE	1.050	'08 '08	••	M478Z04 M478Z03
SPEED TRIPLE	1.050	'09 '12	••	M478Z04 M478Z03
SPEED TRIPLE (SPECIAL EDITION)	1.050	'09 >	••	M478Z04 M478Z03

YAMAHA

YZF R6	600	'99 '02	••	M538Z04 M538Z03
YZF R6	600	'03 >	••	M538Z04 M538Z03
YZF THUNDER CAT	600	'96 >	••	M538Z04 M538Z03
YZF R7	750	'99 >	••	M538Z04 M538Z03
FZ 8	800	'10 >	••	M538Z04 M538Z03
YZF R1	1.000	'07 >	••	M528Z04 M528Z03
YZF R1	1.000	'98 '06	••	M538Z04 M538Z03
YZF R1 SP	1.000	'06 '06	••	M538Z04 M538Z03
YZF THUNDER ACE	1.000	'96 >	••	M538Z04 M538Z03

Le vernici termoviranti e le thermotapes sono utilizzate per monitorare il regime termico dell'impianto frenante in pista: le vernici per il disco freno, le thermotapes per della pinza. Le vernici si applicano sul bordo esterno del disco, distanziando i vari colori di circa 1 cm., aggiungendo eventualmente il diluente nel caso il pigmento si presenti poco fluido. Le thermotapes, invece, si applicano sulla pinza nella zona dei pistoncini.



Code Codice	Description Descrizione	Range
02516811	Thermo tapes / Bande termosensibili	88 / 127 °C.
02516812	Thermo tapes / Bande termosensibili	132 / 171 °C.
02571120	Thermal paints / Vernici termoviranti	See right / Vedi dx

Paint color Colore vernice	Change Temperature Temperature di viraggio	Color after change Colore dopo il viraggio
Green / Verde	~ 430 °C.	White/ Bianco
Orange / Arancio	~ 560 °C.	Yellow/ Giallo
Red / Rosso	~ 630 °C.	White/ Bianco

